

NOTES:

1. STABILIZED CONSTRUCTION SITE ACCESS SHALL BE CONSTRUCTED OF 6 - 8 INCH WASHED, WELL GRADED GRAVEL OR CRUSHED ROCK. MATERIAL SHALL BE PLACED TO A MINIMUM THICKNESS OF 8 INCHES. ROUND ROCK (RIVER ROCK) NOT ALLOWED.
2. LENGTH OF ENTRANCE SHALL BE A MINIMUM OF 50 FEET. WIDTH SHALL BE A MINIMUM OF 15 FEET OR GREATER IF NECESSARY TO COVER ALL VEHICULAR INGRESS AND EGRESS. PROVIDE AMPLE TURNING RADII.
3. THE ENTRANCE SHALL BE KEPT IN GOOD CONDITION BY OCCASIONAL TOP DRESSING WITH MATERIAL AS SPECIFIED IN NOTE 1.
4. ACCESS SHALL BE INSPECTED WEEKLY DURING PERIODS OF HEAVY USAGE, MONTHLY DURING NORMAL USAGE, AND AFTER EACH RAINFALL, WITH MAINTENANCE PROVIDED AS NECESSARY. PERIODIC TOP DRESSING SHALL BE DONE AS NEEDED.

DATE: 09/22/2007		NOT TO SCALE	
REVISION	BY	APPROVED	DATE

CITY OF ELK GROVE - PUBLIC WORKS

STABILIZED CONSTRUCTION SITE ACCESS

APPROVED BY:
Paul Murock 10/24/2018
CITY ENGINEER DATE

DRAWING NUMBER
SQ - 1



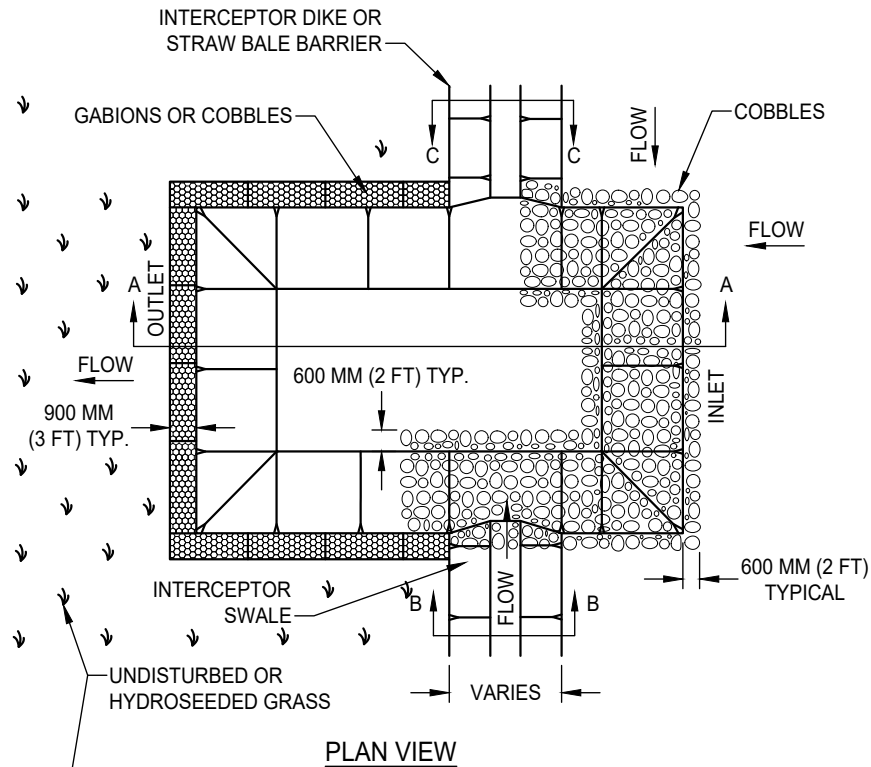

PLAN VIEW

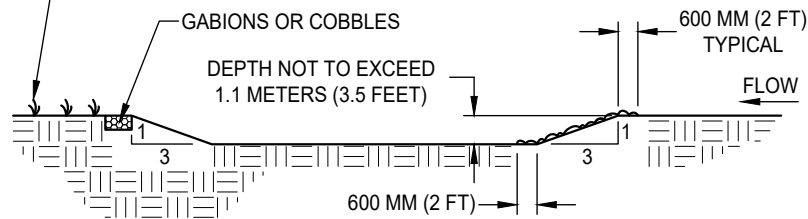

SECTION A-A

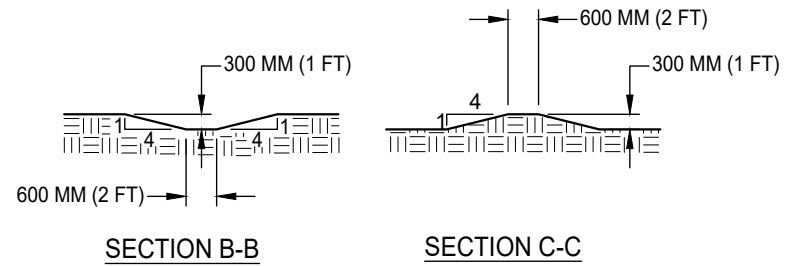

SECTION B-B

SECTION C-C

NOTES:

1. DIMENSIONS OF SEDIMENT TRAPS, DIKES, AND SWALES SHALL BE APPROVED BY THE ADMINISTRATOR.
2. INTERCEPTION DIKES AND SWALES SHALL BE CONSTRUCTED TO DRAIN SURFACE RUNOFF INTO SEDIMENT TRAPS.
3. TRAPS SHALL BE EXCAVATED WITH APPROPRIATE EQUIPMENT, TAKING CARE NOT TO DISTURB VEGETATION OR SOIL AT OUTLET CREST. SIDE SLOPES SHALL BE 1:3 OR FLATTER. MAXIMUM TRAP DEPTH SHALL BE 1.1 METERS (3.5 FEET).
4. COBBLES CONFORMING TO CITY OF ELK GROVE SPECIFICATIONS SHALL BE PLACED ON THE TOPS, SLOPES, AND BOTTOMS OF THE INLET SIDES. COBBLES SHALL EXTEND A MINIMUM OF 600 MM (2 FEET) BEYOND THE TOP AND TOE OF SLOPES.
5. PERIMETER OF SEDIMENT TRAPS SHALL BE STABILIZED WITH GABIONS OR COBBLES AND HYDROSEEDED 3 METERS (10 FEET) BEYOND EDGE OF EXCAVATION IF EXISTING VEGETATION IS THIN, DISTURBED OR NONEXISTENT.
6. THE CONTRACTOR SHALL INSPECT SEDIMENT TRAPS WEEKLY AND AFTER EACH RAINFALL AND CLEAN AND REPAIR AS NECESSARY. SEDIMENT SHALL BE REMOVED FROM THE BOTTOM OF THE TRAP WHEN 300 MM (1 FOOT) DEEP OR LESS.

DATE: 09/22/2007		NOT TO SCALE	
REVISION	BY	APPROVED	DATE

CITY OF ELK GROVE - PUBLIC WORKS

**SEDIMENT TRAP
STABILIZED OUTLET**

APPROVED BY:

Paul Murock

10/24/2018

CITY ENGINEER

DATE



DRAWING NUMBER

SQ - 3

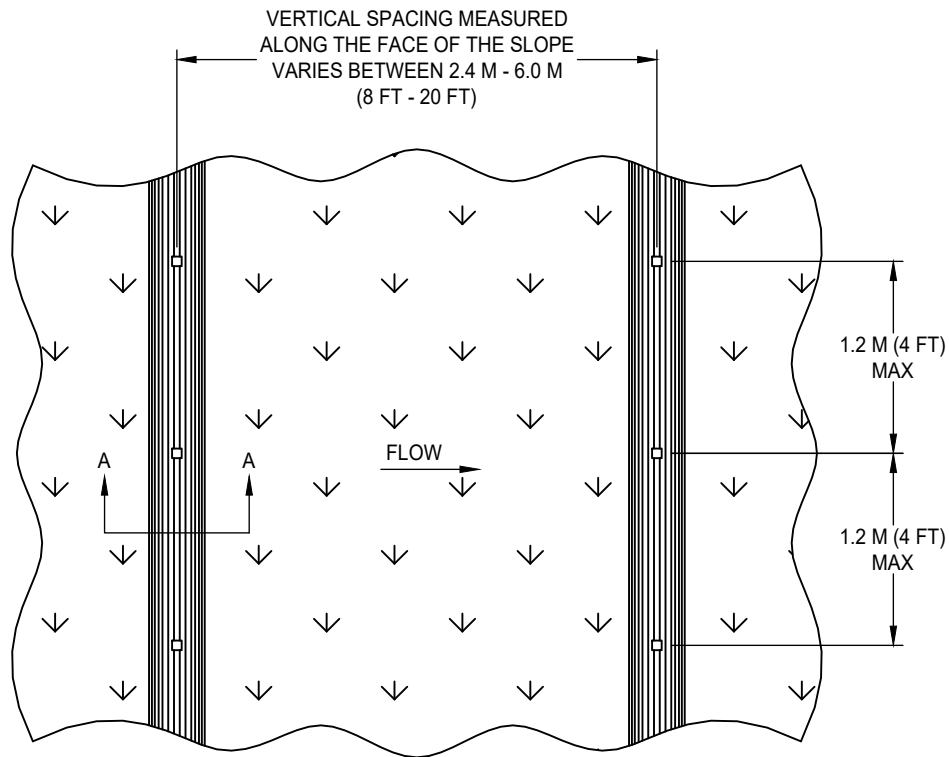

TYPICAL FIBER ROLL INSTALLATION

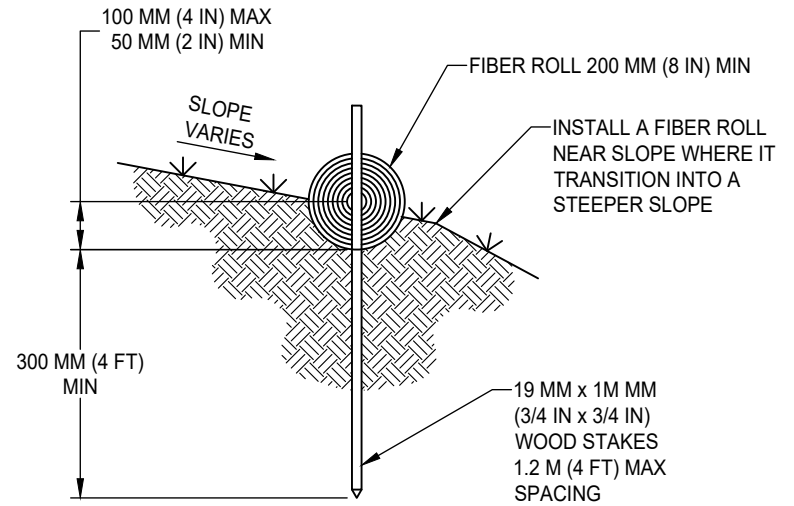

SECTION A-A

NOTES:

1. INSTALL FIBER ROLL IN A ROW ALONG A LEVEL CONTOUR.
2. AT ENDS OF A ROW TURN THE LAST TWO FEET UP SLOPE SLIGHTLY.
3. FIBER ROLLS SHALL BE BUTTED TIGHTLY AT THE JOINTS.
4. DO NOT OVERLAP JOINTS.

DATE: 09/22/2007		NOT TO SCALE	
REVISION	BY	APPROVED	DATE

CITY OF ELK GROVE - PUBLIC WORKS

FIBER ROLLS

APPROVED BY:

Paul M. Muebeck

CITY ENGINEER

10/24/2018

DATE



DRAWING NUMBER

SQ - 4

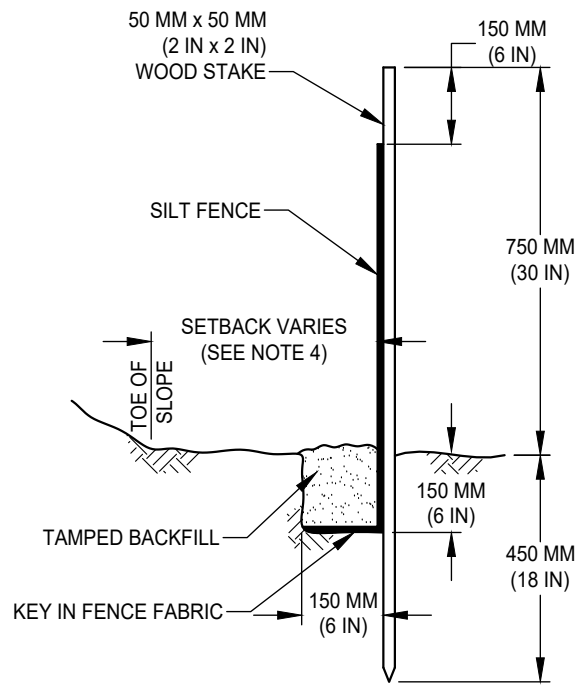

FENCE SECTION DETAIL

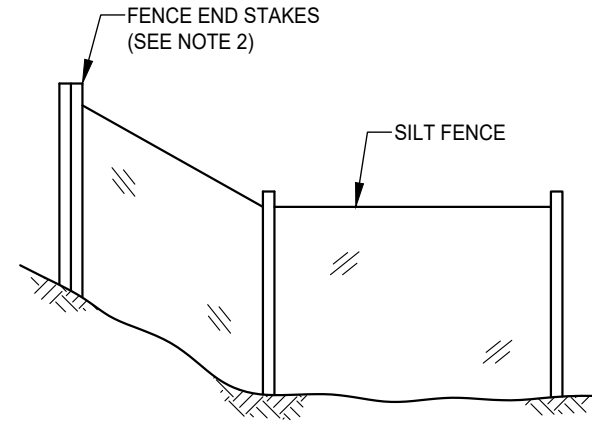

FENCE END DETAIL

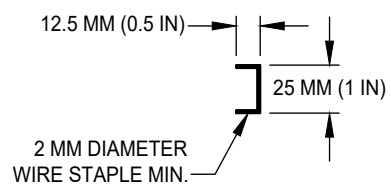

STAPLE DETAIL

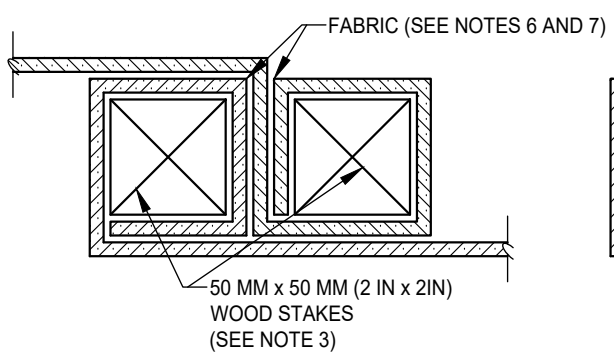

JOINT DETAIL

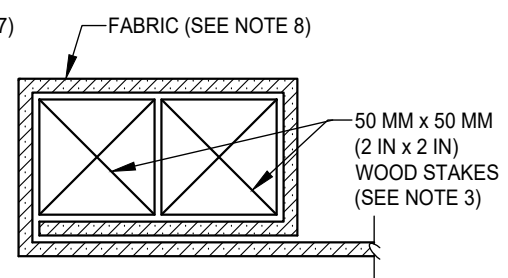

END STAKE DETAIL

NOTES:

1. CONSTRUCT THE LENGTH OF EACH REACH SO THAT THE CHANGE IN BASE ELEVATION ALONG THE REACH DOES NOT EXCEED 1/3 THE HEIGHT OF THE LINEAR BARRIER. IN NO CASE SHALL THE REACH LENGTH EXCEED 150 MM (6 IN)
2. THE LAST 2.4 M (8 FT) OF FENCE SHALL BE TURNED UP SLOPE.
3. STAKE DIMENSIONS ARE NOMINAL.
4. DIMENSIONS MAY VARY TO FIT FIELD CONDITION.
5. STAKES SHALL BE SPACED AT 2.4 M (8 FT) MAXIMUM AND SHALL BE POSITIONED ON THE DOWNSTREAM SIDE OF THE FENCE.
6. OVERLAP STAKES, AND FOLD FENCE FABRIC TO ROUND EACH STAKE ONE FULL TURN.
7. STAKES SHALL BE DRIVEN TIGHTLY TOGETHER TO PREVENT POTENTIAL FLOW THROUGH OF SEDIMENT AT THE JOINT.
8. FOR END STAKE CONDITION FOLD FENCE FABRIC AROUND (2) STAKES (1) FULL TURN AND SECURE WITH (4) STAPLES.
9. MINIMUM (4) STAPLES PER STAKE.
10. CROSS BARRIERS SHALL BE MINIMUM OF 1/3 AND MAXIMUM OF 1/2 THE HEIGHT OF THE LINEAR BARRIER.

DATE: 09/22/2007		NOT TO SCALE	
REVISION	BY	APPROVED	DATE

CITY OF ELK GROVE - PUBLIC WORKS

SILT FENCE

APPROVED BY:
Paul Murock
CITY ENGINEER

10/24/2018
DATE

DRAWING NUMBER
SQ - 5



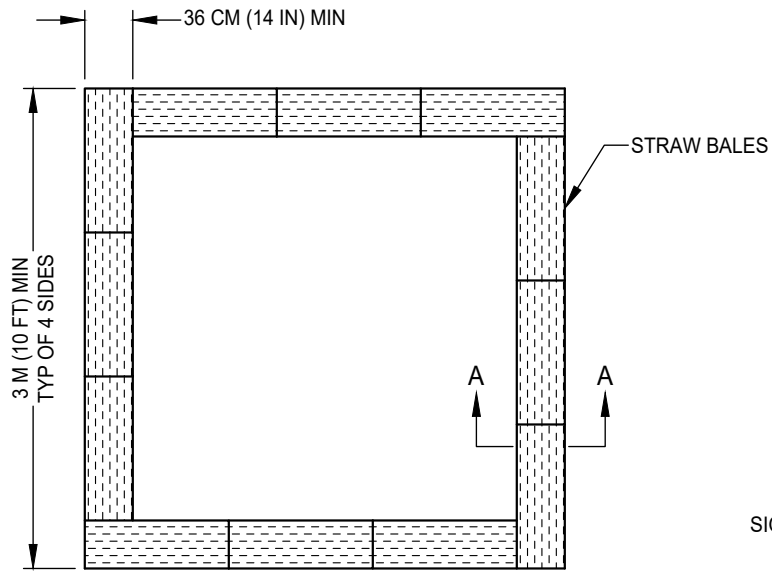

BALE CONFIGURATION

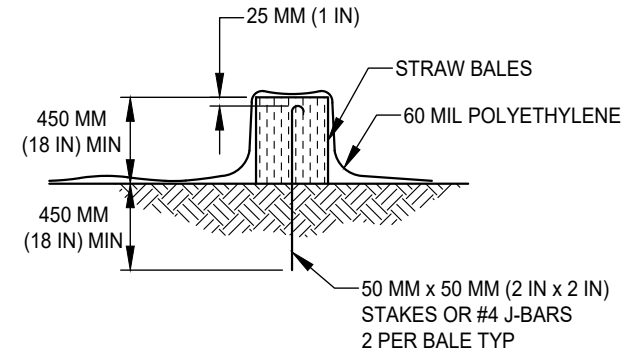

SECTION A-A

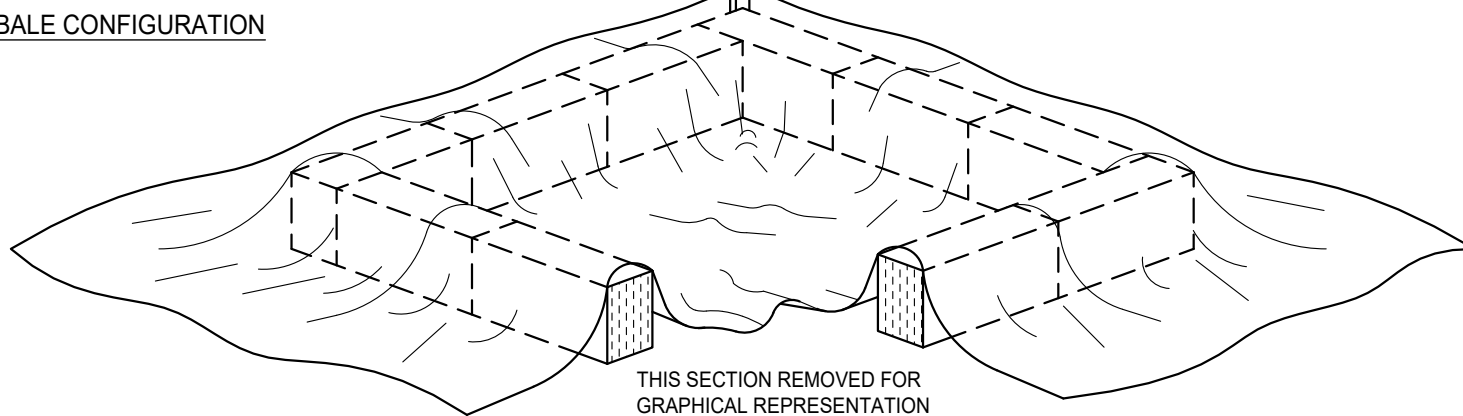
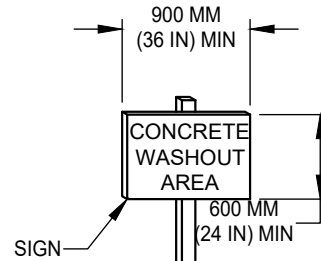

THIS SECTION REMOVED FOR GRAPHICAL REPRESENTATION ONLY. STRAW BALE PERIMETER SHALL BE CONTINUOUS.

NOTES:

1. FACE SIGN TOWARD NEAREST STREET OR ACCESS POINT.
2. CONCRETE WASHOUT SHALL BE LOCATED BEHIND THE CURB AND 15 M (50 FT) MINIMUM FROM DRAINAGE INLETS OR WATERCOURSES.

DATE: 09/22/2007		NOT TO SCALE	
REVISION	BY	APPROVED	DATE

CITY OF ELK GROVE - PUBLIC WORKS

APPROVED BY:

Paul Murock

10/24/2018

CITY ENGINEER

DATE

CONCRETE WASHOUT



DRAWING NUMBER

SQ - 6

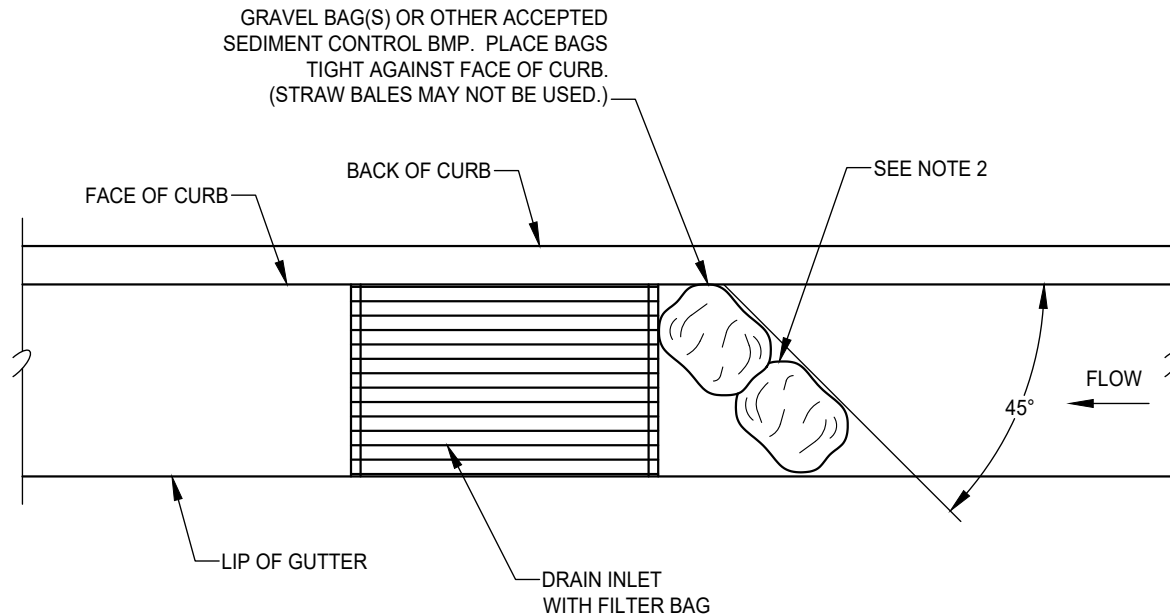

PLAN VIEW

NOTES:

1. SEDIMENT TRAP UPSTREAM OF SEDIMENT CONTROL BMP SHALL BE CLEANED WEEKLY AND PRIOR TO A RAINFALL EVENT.
2. PLACE BAGS TIGHTLY TOGETHER AT JOINTS TO PREVENT OR MINIMIZE SEEPAGE AT JOINTS.

DATE: 09/22/2007		NOT TO SCALE	
REVISION	BY	APPROVED	DATE

CITY OF ELK GROVE - PUBLIC WORKS

INLET SEDIMENT CONTROL

APPROVED BY:

Paul Murock

CITY ENGINEER

10/24/2018

DATE



DRAWING NUMBER

SQ - 7

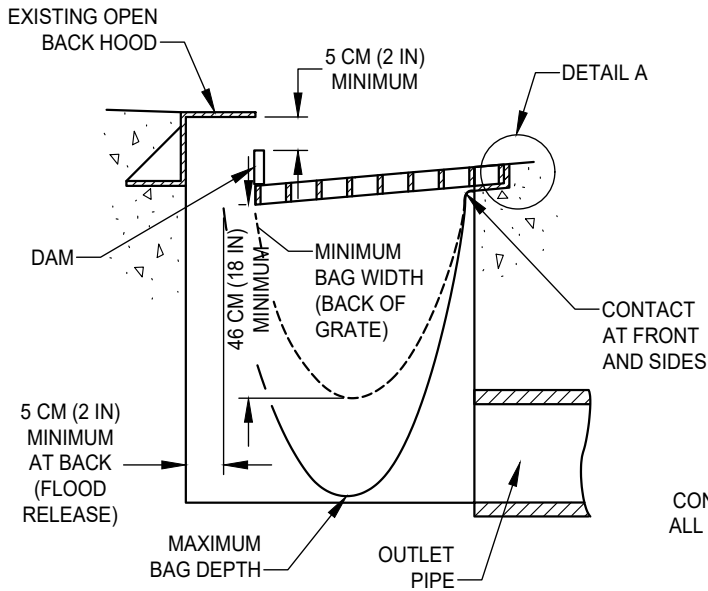

**PLACEMENT AT TYPE B AND E
DROP INLETS**

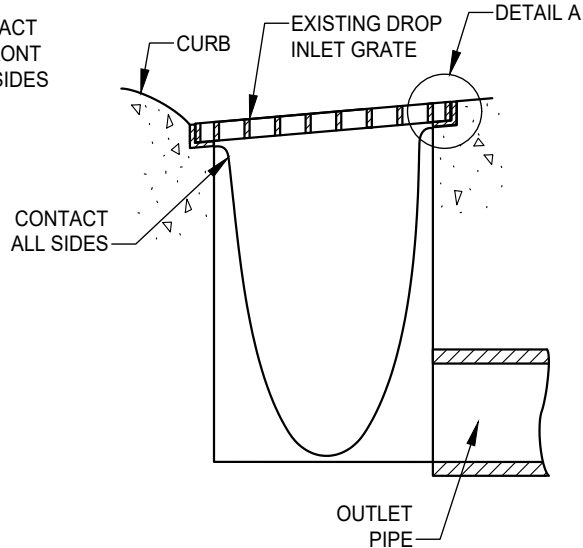

**PLACEMENT AT TYPE A, C, D, & F DROP INLETS
AND PARKING LOTS**

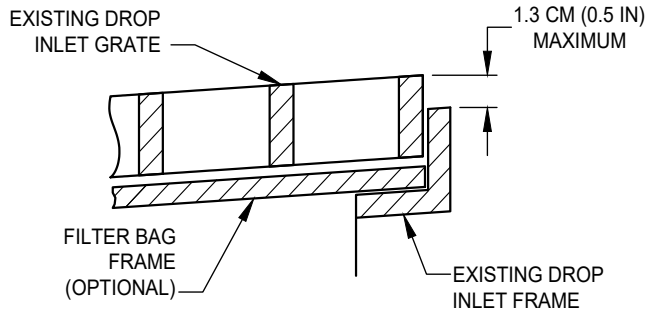

DETAIL A

NOTES:

1. THE MAXIMUM DRAINAGE AREA PER FILTER SHALL BE NO MORE THAN 0.8 HECTARES (2 ACRES).
2. THE FILTER BAG SHALL BE MANUFACTURED FROM UV RESISTANT POLYPROPYLENE, NYLON, POLYESTER, OR ETHYLENE FABRIC WITH A MINIMUM TENSILE STRENGTH OF 50 LBS PER LINEAL FOOT, AN EQUIVALENT OPENING SIZE NOT GREATER THAN 20 SIEVE AND WITH GALLONS/MINUTE/SQ FT.
3. THE FILTER BAG MAY BE SUSPENDED FROM OR HELD IN PLACE ON EXISTING INLET GRATE (OR OTHER APPROVED METHOD), PROVIDING NO MODIFICATION OR DAMAGE SHALL BE DONE TO THE INLET GRATE OR FRAME. THE INLET GRATE SHALL NOT BE CAUSED TO REST MORE THAN 13 MM (0.5 IN) ABOVE THE INLET FRAME (SEE DETAIL A).
4. THE FILTER BAG MAY EXTEND TO THE BOTTOM OF THE INLET BOX PROVIDED THE OUTLET PIPE IS UNOBSTRUCTED.
5. FLOWS SHALL NOT BE ALLOWED TO BYPASS THE BAG. THE BAG OR ITS FRAME SHALL CATCH FLOWS AT ALL SIDES OF THE INLET, EXCEPT AS SHOWN FOR FLOOD RELEASE.
6. INLET FILTER BAGS SHALL BE INSPECTED WEEKLY AND AFTER EACH RAINFALL DURING THE WET SEASON AND MONTHLY DURING THE DRY SEASON. SEDIMENT AND DEBRIS SHALL BE REMOVED BEFORE ACCUMULATIONS HAVE REACHED ONE THIRD THE DEPTH OF THE BAG. BAGS SHALL BE REPAIRED OR REPLACED AS SOON AS DAMAGE OCCURS.

DATE: 09/22/2007		NOT TO SCALE	
REVISION	BY	APPROVED	DATE

CITY OF ELK GROVE - PUBLIC WORKS

STORM DRAIN INLET FILTER BAG

APPROVED BY:
Paul Muroch
CITY ENGINEER

10/24/2018
DATE

DRAWING NUMBER
SQ - 8



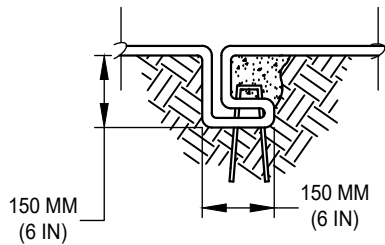

CHECK SLOT

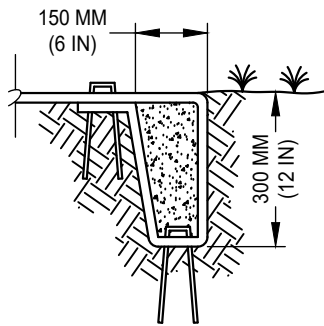

INITIAL CHANNEL ANCHOR TRENCH

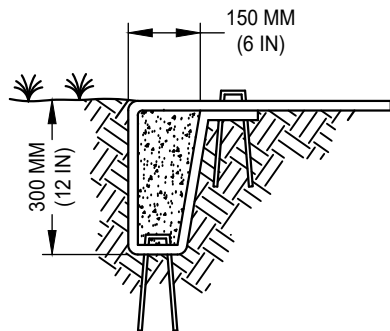

TERMINAL SLOPE AND CHANNEL ANCHOR TRENCH

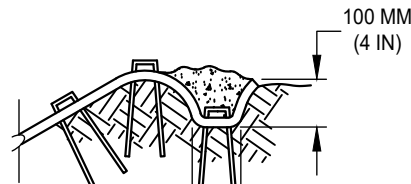
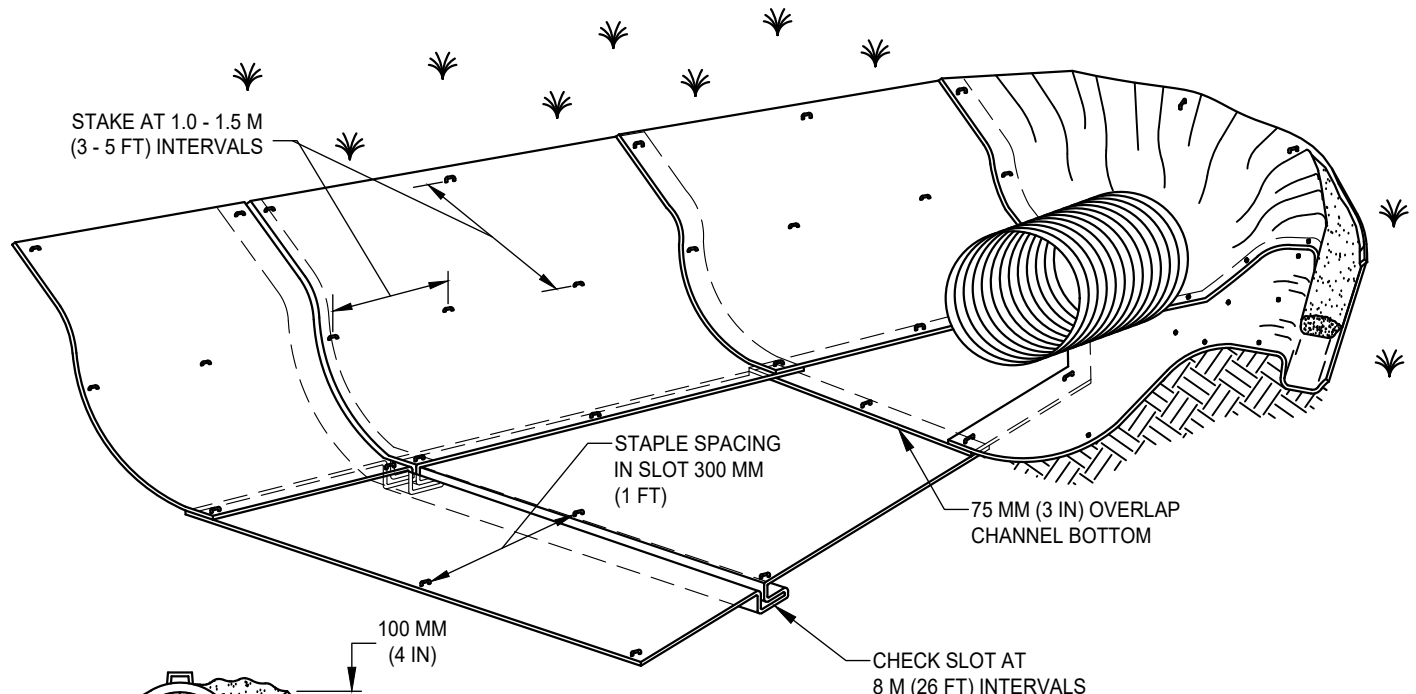

LONGITUDINAL ANCHOR TRENCH

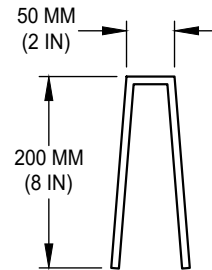

WIRE STAPLES

TYPICAL CHANNEL SOIL STABILIZATION

NOTE:

1. CONSTRUCTION OF CHECK SLOTS, STAKING, STAPLING LAYOUT, AND MAT INSTALLATION ALL TO BE DONE PER MANUFACTURER'S SPECIFICATIONS.

DATE: 09/22/2007		NOT TO SCALE	
REVISION	BY	APPROVED	DATE

CITY OF ELK GROVE - PUBLIC WORKS

EROSION CONTROL BLANKETS / MATS CHANNEL INSTALLATION

APPROVED BY:

Paul Murock

CITY ENGINEER

10/24/2018

DATE



DRAWING NUMBER

SQ - 9A

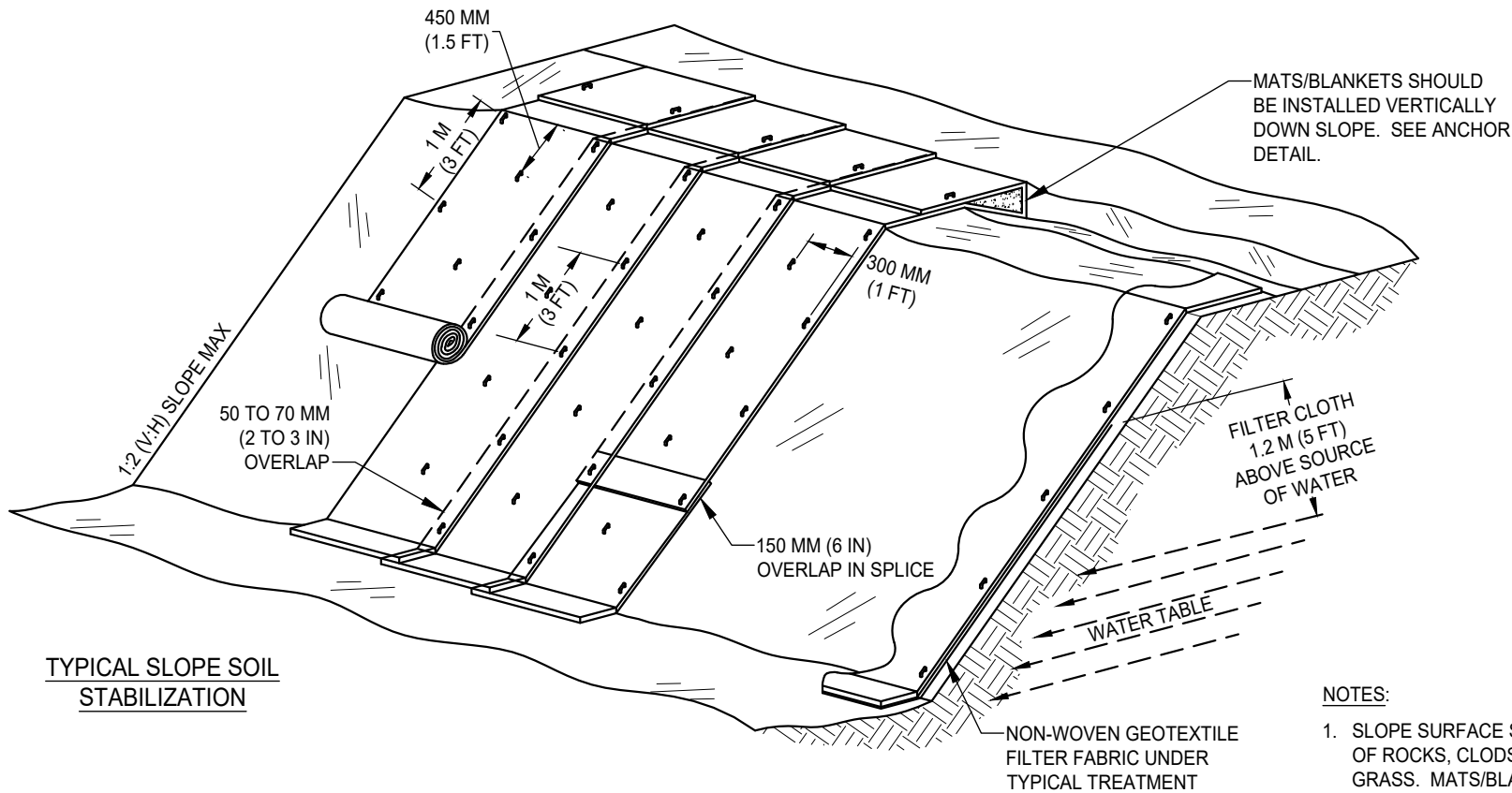

TYPICAL SLOPE SOIL STABILIZATION

WET SLOPE LINING

NOTES:

1. SLOPE SURFACE SHALL BE FREE OF ROCKS, CLODS, STICKS AND GRASS. MATS/BLANKETS SHALL HAVE GOOD SOIL CONTACT.
2. LAY BLANKETS LOOSELY AND STAKE OR STAPLE TO MAINTAIN DIRECT CONTACT WITH THE SOIL. DO NOT STRETCH.
3. INSTALL PER MANUFACTURER'S RECOMMENDATIONS.

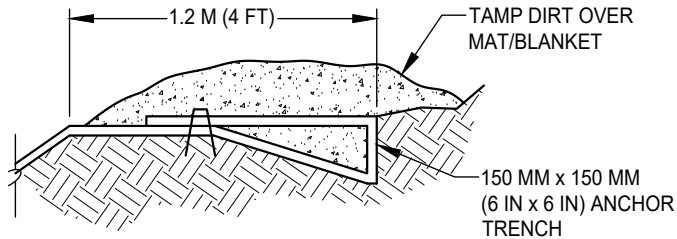

ANCHOR DETAIL

DATE: 09/22/2007		NOT TO SCALE	
REVISION	BY	APPROVED	DATE

CITY OF ELK GROVE - PUBLIC WORKS

EROSION CONTROL BLANKETS/MATS SLOPE INSTALLATION

APPROVED BY:

Paul Murock

10/24/2018

CITY ENGINEER

DATE



DRAWING NUMBER

SQ - 9B

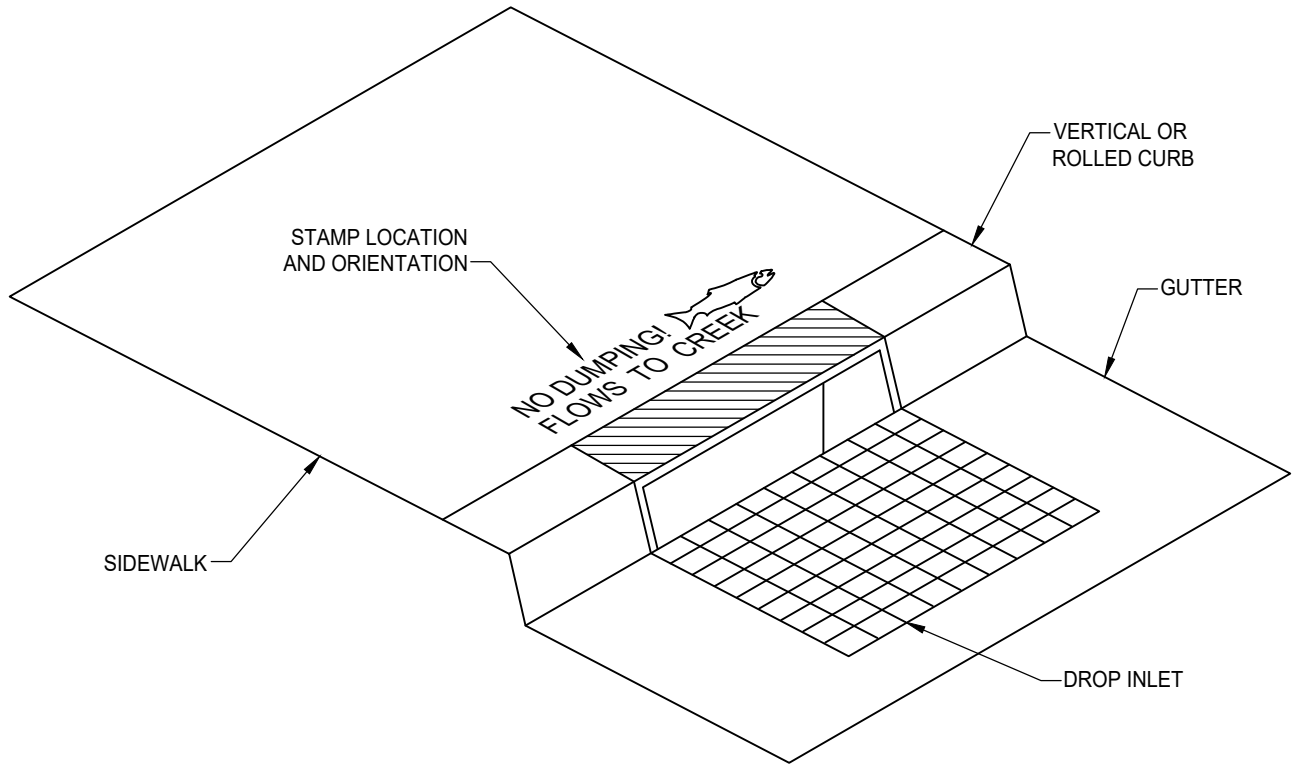

NOTES:

1. MESSAGE AND SYMBOL SHALL BE AS SHOWN ON SQ-10.2 OR AS APPROVED BY THE DIRECTOR.
2. LETTERS SHALL BE 1.5 INCHES (38 MM) IN HEIGHT. THE MESSAGE SHALL BE CENTERED ON THE BACK OF THE INLET.
3. CONCRETE SHALL BE STAMPED IN SUCH A WAY AS TO PROVIDE FOR A CLEAR AND LEGIBLE IMAGE. (APPROXIMATE DEPTH OF 0.25 INCH OR 6 MM).

DATE: 09/22/2017		NOT TO SCALE	
REVISION	BY	APPROVED	DATE

CITY OF ELK GROVE - PUBLIC WORKS

**DROP INLET CONCRETE STAMP
(SHEET 1 OF 2)**

APPROVED BY:
Paul Murock 10/24/2018
CITY ENGINEER DATE

DRAWING NUMBER
SQ - 10.1



STAMP MESSAGES AND SYMBOLS

DIMENSIONS MAY VARY AMONG THE STAMP DESIGNS SHOWN BELOW, BUT SHALL NOT EXCEED THE MAXIMUM DIMENSIONS.



DATE: 09/22/2017		NOT TO SCALE	
REVISION	BY	APPROVED	DATE

CITY OF ELK GROVE - PUBLIC WORKS

**DROP INLET CONCRETE STAMP
(SHEET 2 OF 2)**

APPROVED BY:
Paul Murbach 10/24/2018
CITY ENGINEER DATE

DRAWING NUMBER
SQ - 10.2

