

TYPICAL STREET LIGHTS

SERIES 'A'

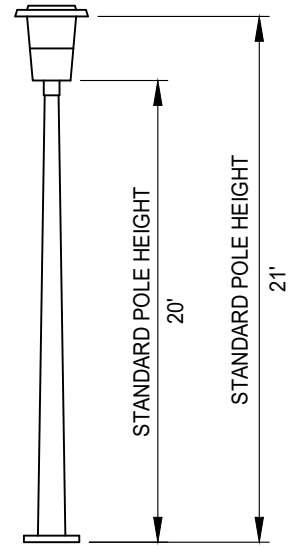

SERIES 'B'

**SYMBOLS**

| PROPOSED | EXISTING |                              |
|----------|----------|------------------------------|
|          |          | .....SERIES 'A' STREET LIGHT |
|          |          | .....SERIES 'B' STREET LIGHT |
|          |          | .....PULL BOX                |
|          |          | .....SERVICE POINT PULL BOX  |
|          |          | .....CONDUIT                 |
|          |          | .....SERVICE ENCLOSURE       |
|          |          | .....U.G. UTILITY SERVICE    |
|          |          | .....TRANSFORMER             |
|          |          | .....WOOD POLE               |

|                     |    |              |      |
|---------------------|----|--------------|------|
| DATE:<br>09/22/2017 |    | NOT TO SCALE |      |
| REVISION            | BY | APPROVED     | DATE |
|                     |    |              |      |
|                     |    |              |      |
|                     |    |              |      |

CITY OF ELK GROVE - PUBLIC WORKS

APPROVED BY:  
*Paul Murbach*  
CITY ENGINEER      10/24/2018  
DATE

**STREET LIGHTING  
POLES AND SYMBOLS**



DRAWING NUMBER  
**SL - 1**

| STREET CLASSIFICATION | RIGHT-OF-WAY WIDTH | STREET LIGHT SUB-TYPE (SERIES) | STANDARD MOUNTING TYPE | AVERAGE MAINTAINED FOOTCANDLE | MAINTENANCE FACTOR |
|-----------------------|--------------------|--------------------------------|------------------------|-------------------------------|--------------------|
| SPECIAL THOROUGHFARE  | 118'               | A                              | 30' - 9"               | 0.57                          | 0.65               |
| THOROUGHFARE          | 96'                | A                              | 30' - 9"               | 0.56                          | 0.65               |
| ARTERIAL              | 72'                | A                              | 30' - 9"               | 0.36                          | 0.65               |
| COLLECTOR             | 60'                | A                              | 30' - 9"               | 0.26                          | 0.65               |
| RESIDENTIAL           | < 50'              | B                              | 21'                    | 0.13                          | 0.70               |
| PEDESTRIAN LANE       | --                 | B                              | 14'                    | 0.17                          | 0.70               |

**NOTES:**

1. LUMENS USED TO CALCULATE THE AVERAGE MAINTAINED FOOTCANDLE SHALL BE 80% OF INITIAL LUMEN VALUE RATED BY THE LAMP MANUFACTURER.

|                     |    |              |      |  |  |   |                    |
|---------------------|----|--------------|------|--|--|---|--------------------|
| DATE:<br>09/22/2007 |    | NOT TO SCALE |      | CITY OF ELK GROVE - PUBLIC WORKS                 |  | APPROVED BY:<br><i>Paul Murock</i>  |                    |
| REVISION            | BY | APPROVED     | DATE | <b>STREET LIGHTING ILLUMINATION<br/>CRITERIA</b> |  | CITY ENGINEER   | 10/24/2018<br>DATE |
|                     |    |              |      |  |  |  | DRAWING NUMBER     |
|                     |    |              |      |  |  |   | <b>SL - 2</b>      |
|                     |    |              |      |  |  |   |                    |

ELECTROLIER MUST BE GROUNDED BACK TO THE SERVICE POINT

GALVANIZED ANCHOR BOLTS \*\*

BASE PLATE \*\*

SIDEWALK FINISH (IF APPLICABLE)

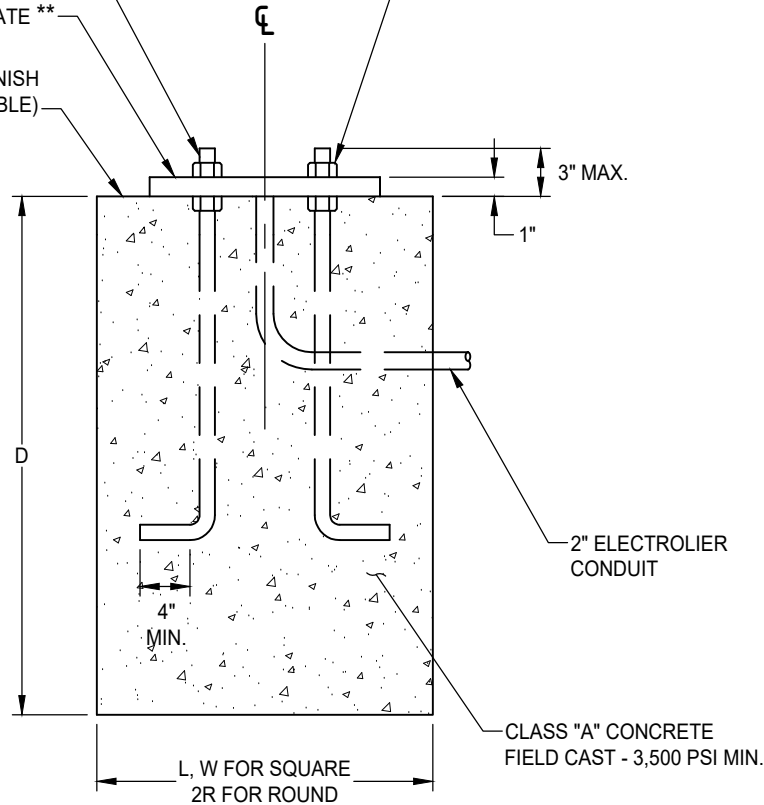

ELEVATION

| MINIMUM FOUNDATION DIMENSIONS * |                                |        |     |       |       |       |
|---------------------------------|--------------------------------|--------|-----|-------|-------|-------|
| STREET LIGHT AREAS              | STREET LIGHT SUB-TYPE (SERIES) | SQUARE |     |       | ROUND |       |
|                                 |                                | L      | W   | D     | R     | D     |
| CT                              | SERIES 'A'                     | 30"    | 30" | 5'    | 15"   | 5'    |
| CT, OT, LW                      | SERIES 'B'                     | 24"    | 24" | 4'    | 12"   | 4'    |
| LW, ZONE 2                      | SERIES 'A'                     | 30"    | 30" | 6'-6" | 15"   | 6'-6" |
| ZONE 2                          | SERIES 'B'                     | 24"    | 24" | 4'-6" | 12"   | 4'-6" |

CT - COMMON TYPE  
 OT - OLD TOWN  
 LW - LAGUNA WEST

SEE STANDARD DRAWING SL-19 FOR STREET LIGHT AREAS

- \* STABLE SOILS ONLY. UNSTABLE SOIL MAY REQUIRE A DEEPER FOUNDATION AS DETERMINED BY THE DESIGN ENGINEER.
- \* IN LIEU OF USING THE STANDARD MINIMUM DIMENSIONS, A LICENSED PROFESSIONAL ENGINEER MAY SUBMIT A SITE-SPECIFIC (BY STREET LIGHT TYPE/LOCATION) FOUNDATION DESIGN FOR APPROVAL. FOUNDATION DESIGN MUST CONFORM TO AASHTO "STANDARD SPECIFICATIONS FOR STRUCTURAL SUPPORTS FOR HIGHWAY SIGNS, LUMINAIRES, AND TRAFFIC SIGNALS."
- \*\* ANCHOR BOLT SIZES AND BASE PLATE SHALL BE PURSUANT TO THE POLE MANUFACTURER'S DESIGN REQUIREMENTS, WHICH SHALL BE IN ACCORDANCE WITH AASHTO "STANDARD SPECIFICATIONS FOR STRUCTURAL SUPPORTS FOR HIGHWAY SIGNS, LUMINAIRES, AND TRAFFIC SIGNALS."

|                    |     |              |            |
|--------------------|-----|--------------|------------|
| DATE<br>09/22/2007 |     | NOT TO SCALE |            |
| REVISION           | BY  | APPROVED     | DATE       |
| 01                 | STN | JRW          | 02/16/2021 |
|                    |     |              |            |
|                    |     |              |            |

CITY OF ELK GROVE - PUBLIC WORKS

APPROVED BY:

*Robert M. Mudgett*

02/26/2021

CITY ENGINEER

DATE

STREET LIGHT FOUNDATIONS



DRAWING NUMBER

SL - 3

| PULL BOX No. | REINFORCED CONCRETE BOX |                             |         |         | COMPOSITE BOX    |                             | REINFORCED CONC. OR COMPOSITE COVER |         |        |                |            |
|--------------|-------------------------|-----------------------------|---------|---------|------------------|-----------------------------|-------------------------------------|---------|--------|----------------|------------|
|              | MIN.** THICKNESS        | MIN DEPTH BOX AND EXTENSION | LO      | WO      | MIN.** THICKNESS | MIN DEPTH BOX AND EXTENSION | L***                                | W***    | R      | EDGE THICKNESS | EDGE TAPER |
| 3-1/2        | 1"                      | NO EXTENSION                | 20"     | 14"     | 5/16"            | NO EXTENSION                | 15-3/8"                             | 10-1/8" | 1-1/8" | 1-3/4"         | 1/8"       |
| 5            | 1"                      | 22"                         | 28"     | 18"     | 5/16"            | 20"                         | 23-1/4"                             | 13-3/4" | 1-1/4" | 2"             | 1/8"       |
| 5A           | 1"                      | 22"                         | 25-1/4" | 15-3/4" | 5/16"            | 20"                         | 20-5/8"                             | 10-1/2" | 1-1/4" | 2"             | 1/8"       |
| 6            | 1-1/2"                  | 24"                         | 36"     | 23"     | 3/8"             | 20"                         | 30-5/8"                             | 17-5/8" | 1-1/4" | 2"             | 1/8"       |
| P44          | 1-1/2"                  | 20"                         | 47-1/2" | 28-1/4" | -                | -                           | 43-1/8"                             | 21-1/4" | 1-1/2" | 2"             | 1/8"       |

NOTES:

- IN UNIMPROVED AREAS, THE TOP OF PULL BOXES SHALL BE PLACED 0.10 FOOT ABOVE THE SURROUNDING GRADE OR, WHEN ADJACENT TO A CURB, FLUSH WITH THE TOP OF THE CURB. THE SURROUNDING GRADE SHALL BE RAMPED UP TO MATCH THE TOP OF THE CONCRETE COLLAR. UNLESS OTHERWISE NOTED, PULL BOXES SHOWN IN THE VICINITY OF SIDEWALK SHALL BE PLACED ADJACENT TO THE BACK OF SIDEWALK, AND PULL BOXES SHOWN ADJACENT TO POLES SHALL BE PLACED ON THE SIDE OF THE FOUNDATION FACING AWAY FROM TRAFFIC.
- PLACEMENT OF PULL BOXES IN AREAS SUBJECT TO VEHICULAR TRAFFIC LOADS (INCLUDES TRAFFIC LANES, BIKE LANES, SHOULDERS, AND DRIVEWAYS) SHALL BE AVOIDED WHENEVER POSSIBLE. IF UNAVOIDABLE, THEN A TRAFFIC RATED PULL BOX WITH STEEL TRAFFIC COVER SHALL BE USED. SEE STANDARD DRAWING SL-5.
- PULL BOXES SHALL NOT BE PLACED WITHIN THE BOUNDARIES AND SIDEWALK RAMPS.
- FINAL LOCATION OF ALL PULL BOXES SHALL BE APPROVED BY CITY INSPECTOR PRIOR TO PLACEMENT.
- PULL BOX COVERS SHALL BE MARKED AS FOLLOWS:
  - "TRAFFIC SIGNAL" TRAFFIC SIGNAL CIRCUITS WITH OR WITHOUT STREET LIGHTING CIRCUITS.
  - "STREET LIGHTING" STREET LIGHTING CIRCUITS WHERE NO VOLTAGE IS ABOVE 600V.
  - "STREET LIGHTING-HIGH VOLTAGE" STREET LIGHTING CIRCUITS WHERE VOLTAGE IS ABOVE 600V.
  - "SERVICE" SERVICE CIRCUITS BETWEEN SERVICE POINT AND SERVICE DISCONNECT.
  - "SPRINKLER CONTROL" SPRINKLER CONTROL CIRCUITS, 50 VOLTS OR LESS.
  - "IRRIGATION" CIRCUIT FOR IRRIGATION CONTROLLER, 120 VOLTS OR MORE.
  - "RAMP METER" RAMP METER CIRCUITS.
  - "COUNT STATION" COUNT AND/OR SPEED MONITOR CIRCUITS.
  - "TELEPHONE" TELEPHONE SERVICE.
  - "TOS COMMUNICATIONS" TOS COMMUNICATIONS TRUNK LINE.
  - "TOS POWER" TOS POWER.
  - "TDC POWER" TELEPHONE DEMARCATION CABINET POWER.
  - "SIGNAL INTERCONNECT" TRAFFIC SIGNAL INTERCONNECT CIRCUIT.
- COVERS SHALL FIT FLUSH WITH THE TOP OF PULL BOXES. THERE SHALL BE 1/8" MAXIMUM CLEARANCE ALL AROUND BETWEEN COVERS AND PULL BOX OPENINGS.
- ALL COVERS AND BOXES SHALL BE INTERCHANGEABLE WITH CALIFORNIA STANDARD MALE AND FEMALE GAUGES. WHEN INTERCHANGED WITH STANDARD MALE OR FEMALE GAUGE, THE TOP SURFACES SHALL BE FLUSH WITHIN 1/8 INCH.
- THE TOP EDGES OF ALL CONCRETE COVER AND PULL BOXES SHALL HAVE A 1/4" MINIMUM RADIUS.
- STACKING OF PULL BOXES IS PERMITTED (TWO PULL BOXES MINIMUM).
- STEEL REINFORCING SHALL BE A REGULARLY USED IN THE STANDARD PRODUCTS OF THE RESPECTIVE MANUFACTURER.
- PULL BOXES FOR STREET LIGHTING, UPON COMPLETION OF BURN TEST, SHALL BE FILLED WITH CONTROLLED DENSITY BACKFILL, PER CITY OF ELK GROVE CONSTRUCTION SPECIFICATIONS SECTION 50-15. A 5 MIL. PLASTIC SHEET SHALL COVER THE CONDUITS/WIRES PRIOR TO POURING OF BACKFILL TO A DEPTH OF TWO (2) INCHES OVER THE CONDUITS.
- WHEN NON-METALLIC CONDUIT IS USED AND CONDUIT SWEEPS ARE METALLIC, THE BONDING JUMPER SHALL BE CONNECTED TO THE SWEEP GROUND BUSHINGS AND SHALL BE SPLICED TO THE GROUND WIRE IN THE CONDUIT.

\*\* EXCLUDING CONDUIT WEB \*\*\* TOP DIMENSION

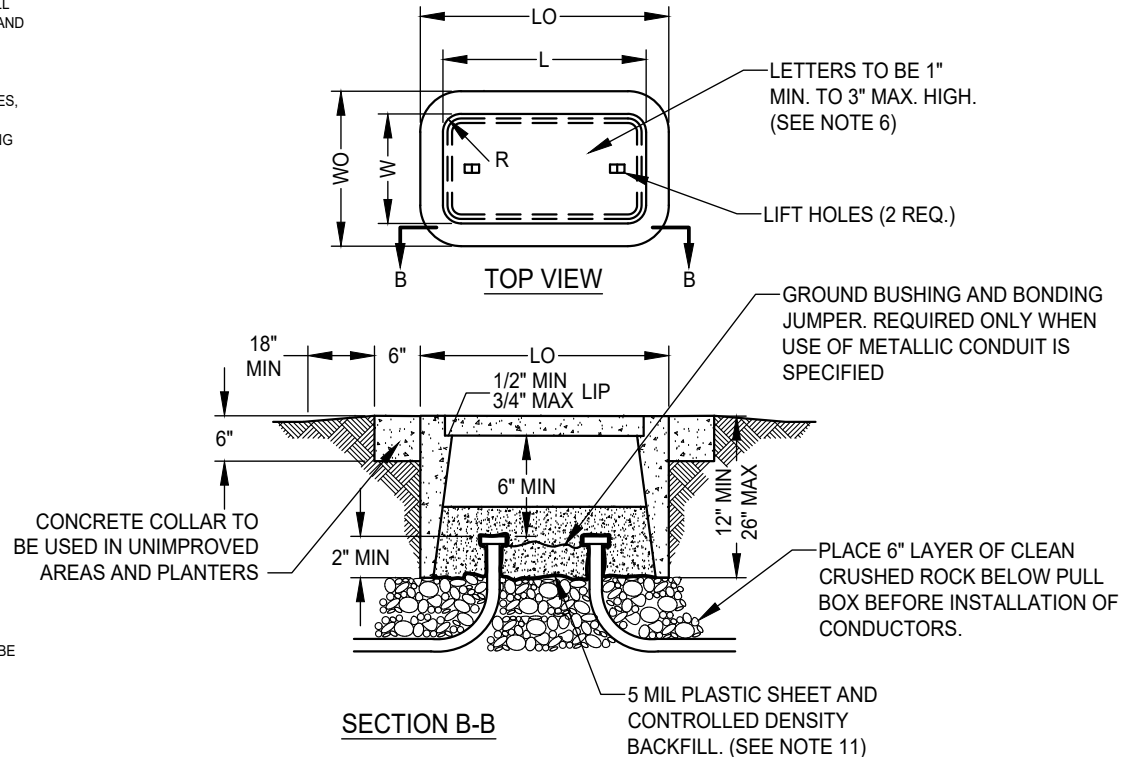

|                     |     |              |            |
|---------------------|-----|--------------|------------|
| DATE:<br>09/22/2007 |     | NOT TO SCALE |            |
| REVISION            | BY  | APPROVED     | DATE       |
| 1                   | SJB | SMA          | 04-12-2024 |
|                     |     |              |            |
|                     |     |              |            |

CITY OF ELK GROVE - PUBLIC WORKS

STANDARD PULL BOX

APPROVED BY:  05-28-2024  
CITY ENGINEER DATE



DRAWING NUMBER  
**SL - 4**

PULL BOXES SHALL BE PLACED BEHIND THE SIDEWALK OR IN THE PLANTER AREA WHENEVER POSSIBLE. TRAFFIC RATED BOXES AND COVERS SHALL BE USED IF A PULL BOX MUST BE INSTALLED IN THE SIDEWALK OR DRIVEWAY.

**NOTES:**

1. STEEL COVER SHALL HAVE EMBOSSED NON-SKID PATTERN.
2. STEEL REINFORCING SHALL BE AS REGULARLY USED IN THE STANDARD PRODUCTS OF THE RESPECTIVE MANUFACTURER.
3. PULL BOX COVERS SHALL BE MARKED AS DESCRIBED IN NOTE 5 ON STANDARD DRAWING SL-4. MARKING SHALL BE APPLIED TO EACH COVER PRIOR TO GALVANIZING BY BEAD WELDING THE LETTERS ON THE COVERS. THE LETTERS SHALL BE RAISED AT LEAST 3/32 INCH.
4. BONDING JUMPER FOR COVER SHALL BE A MIN. OF 36" LONG. WHEN NON-METALLIC CONDUIT IS USED, THE BONDING JUMPER SHALL INCORPORATE CONNECTION TO THE METALLIC CONDUIT SWEEPS AND BE SPLICED TO THE GROUND WIRE IN THE CONDUITS. WHEN THE USE OF METALLIC CONDUIT IS SPECIFIED, THE BONDING JUMPER FOR THE COVER SHALL BE CONNECTED TO THE CONDUIT GROUND BUSHING, AND THE CONDUITS SHALL BE BONDED TOGETHER WITH GROUND BUSHINGS AND A BONDING JUMPER.
5. CONDUITS SHALL ENTER AT BOTTOM OF PULL BOX AS SHOWN IN THE DRAWING.
6. PULL BOXES FOR STREET LIGHTING, UPON COMPLETION OF BURN TEST, SHALL BE FILLED WITH CONTROLLED DENSITY BACKFILL PER CITY OF ELK GROVE CONSTRUCTION SPECIFICATIONS SECTION 50-15. A 5 MIL. PLASTIC SHEET SHALL COVER THE CONDUITS/WIRES PRIOR TO POURING OF BACKFILL, TO A DEPTH OF TWO (2) INCHES OVER THE CONDUITS.

| REINFORCED CONCRETE BOX |                  |                              |         |         |          |          |
|-------------------------|------------------|------------------------------|---------|---------|----------|----------|
| PULL BOX No.            | MIN.** THICKNESS | MIN. DEPTH BOX AND EXTENSION | LO      | WO      | L        | W        |
| 3-1/2                   | 1"               | NO EXTENSION                 | 20"     | 14"     | 15-1/2"± | 10"±     |
| 5                       | 1"               | 22"                          | 28"     | 18"     | 23"±     | 13-1/2"± |
| 5A                      | 1"               | 22"                          | 25-1/4" | 15-3/4" | 21"±     | 10-1/2"± |

\*\* EXCLUDING CONDUIT WEB

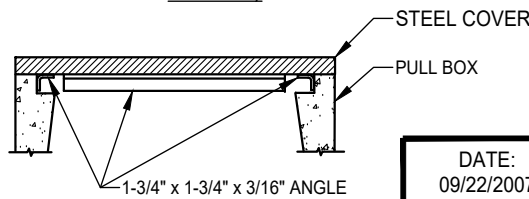
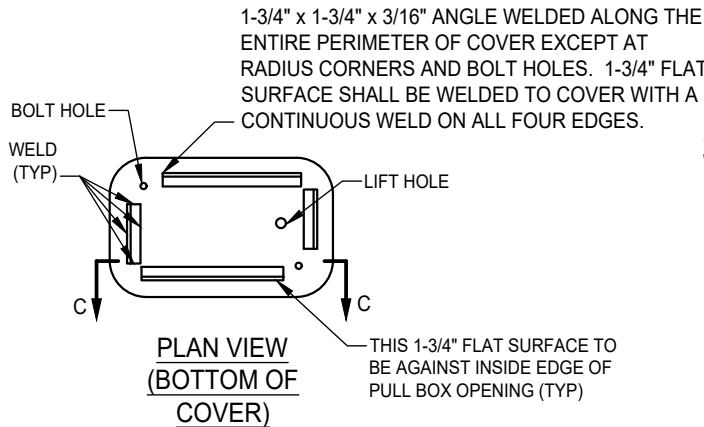
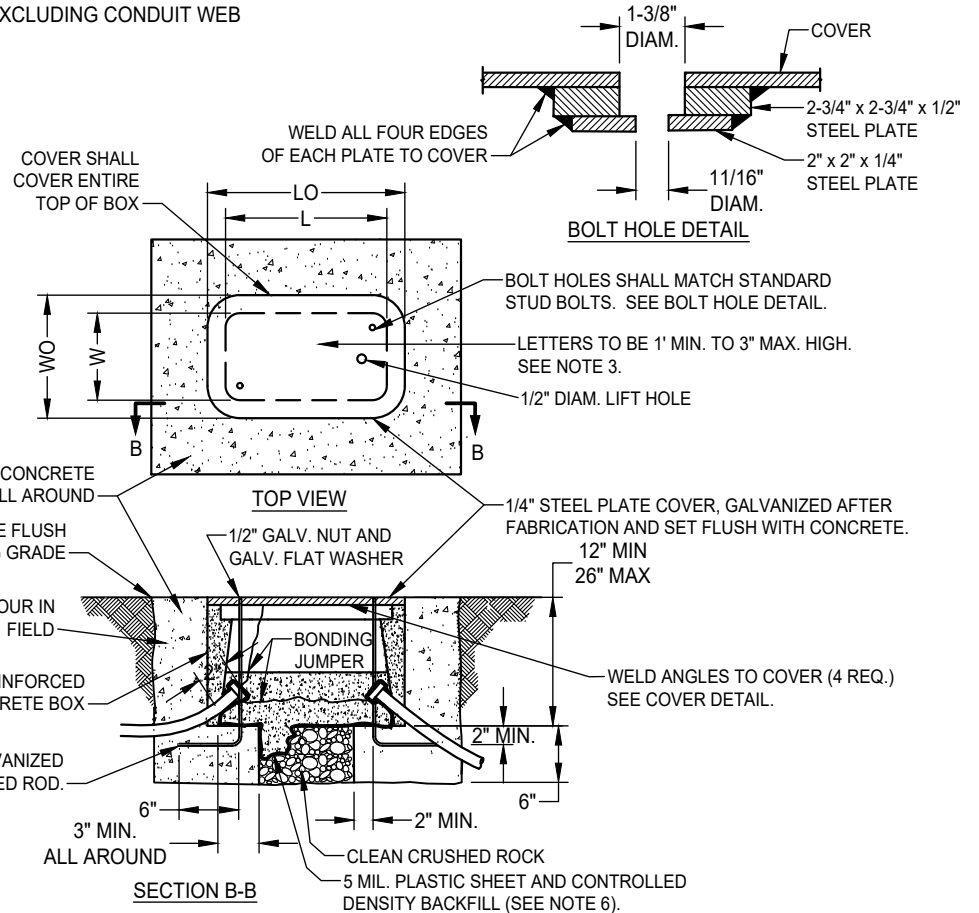

SECTION C-C  
COVER DETAIL

| DATE:<br>09/22/2007 |     | NOT TO SCALE |            |
|---------------------|-----|--------------|------------|
| REVISION            | BY  | APPROVED     | DATE       |
| 1                   | SJB | SMA          | 04-12-2024 |
|                     |     |              |            |
|                     |     |              |            |

CITY OF ELK GROVE - PUBLIC WORKS

TRAFFIC-RATED PULL BOX

APPROVED BY:

*[Signature]* 05-28-2024

CITY ENGINEER

DATE



DRAWING NUMBER

SL - 5

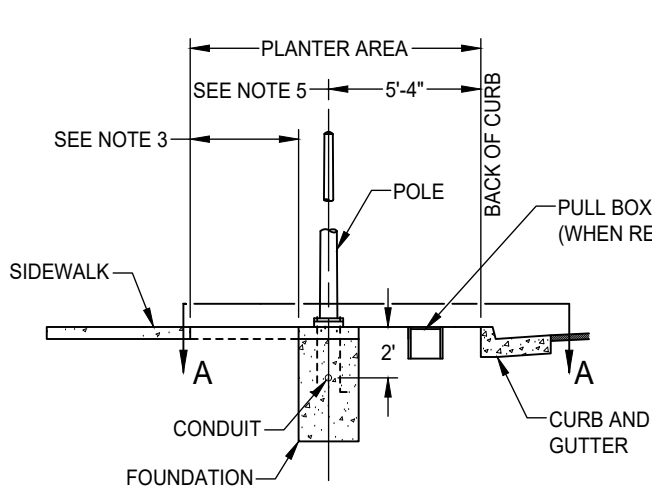

**SIDEWALK WITH PLANTER AREA**

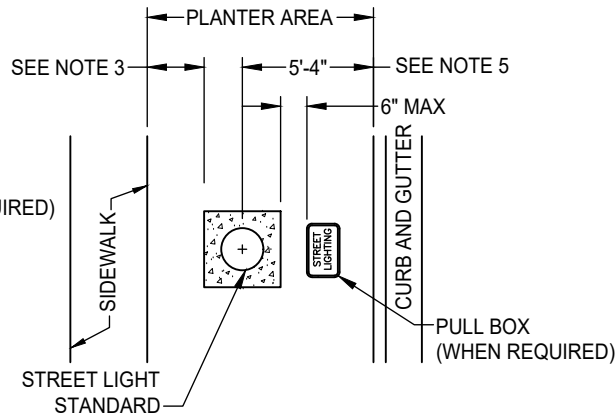

**SECTION A-A**

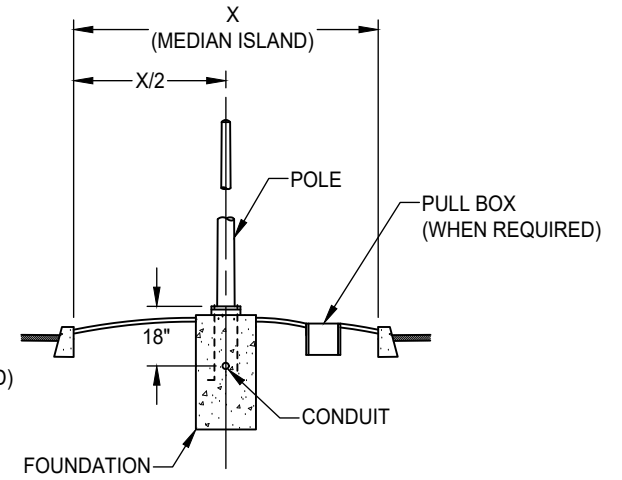

**MEDIAN**

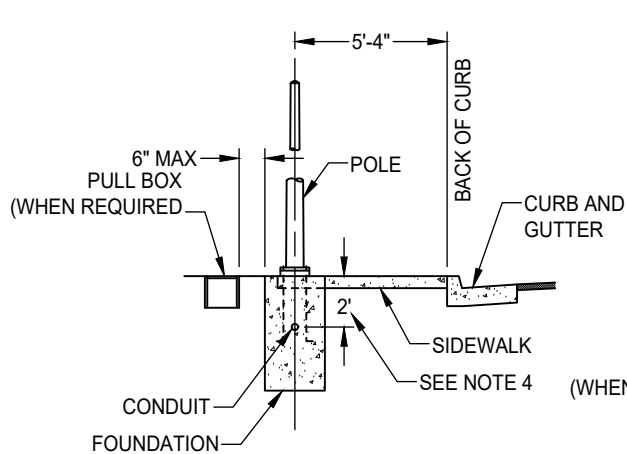

**5' TO 6' SIDEWALK**

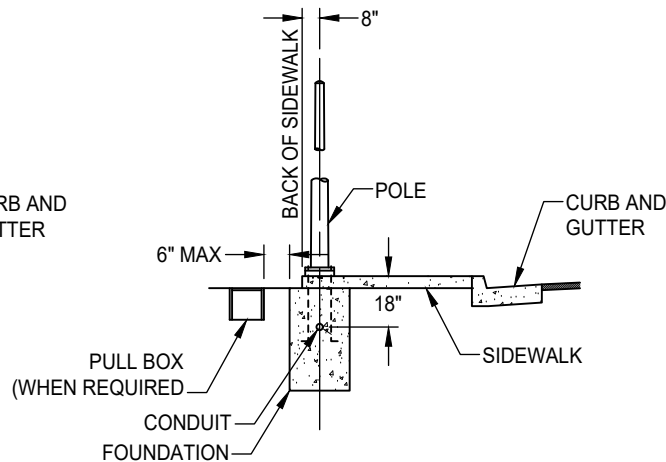

**OVER 6' SIDEWALK**

**NOTES:**

1. BACKFILL FOR CONDUIT TRENCH LOCATED UNDER CURB, GUTTER & SIDEWALK AND IN UNIMPROVED AREAS SHALL BE COMPACTED TO 90% RELATIVE COMPACTION. BACKFILL FOR CONDUIT TRENCH LOCATED IN PAVEMENT SHALL BE COMPACTED TO 95% RELATIVE COMPACTION.
2. LANDSCAPING IN THE AREA OF THE STREET LIGHT STANDARD TO MATCH BASE ELEVATION AND HAVE A MINIMUM OF 12" OF CLEARANCE FROM THE BASE.
3. IF THIS LENGTH IS 12" OR LESS, PLACE 3-1/2" THICK CONCRETE FROM STREET LIGHT BASE TO EDGE OF SIDEWALK. WIDTH TO MATCH CONCRETE AROUND STREET LIGHT FOUNDATION.
4. IF CONDUIT IS LOCATED BENEATH THE SIDEWALK, IT MAY BE PLACED AT 18" DEPTH INSTEAD OF 2'.
5. IF THE PLANTER AREA IS LESS THAN 6' WIDE, THEN PLACE STREET LIGHT SO THAT THE BASE PLATE ALIGNS WITH THE EDGE OF SIDEWALK. TOP OF FOUNDATION TO MATCH SIDEWALK GRADE.
6. PULL BOXES SHALL NOT BE PLACED IN SIDEWALK. THEY SHALL BE PLACED IN PUE OR PLANTER AREA.

|                     |    |              |      |
|---------------------|----|--------------|------|
| DATE:<br>09/22/2007 |    | NOT TO SCALE |      |
| REVISION            | BY | APPROVED     | DATE |
|                     |    |              |      |
|                     |    |              |      |
|                     |    |              |      |

**CITY OF ELK GROVE - PUBLIC WORKS**

**BASE LOCATION FOR STREET LIGHT**

APPROVED BY:  
*Paul Murock*  
CITY ENGINEER

10/24/2018  
DATE

DRAWING NUMBER  
**SL - 6**



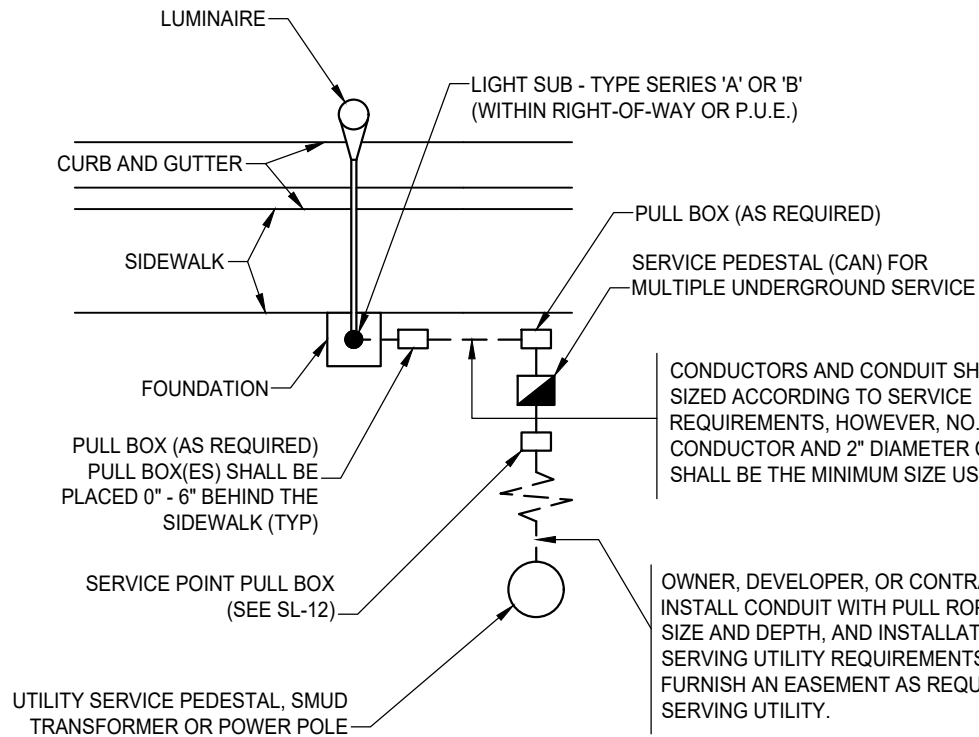

CONDUCTORS AND CONDUIT SHALL BE SIZED ACCORDING TO SERVICE REQUIREMENTS, HOWEVER, NO. 8 A.W.G. CONDUCTOR AND 2" DIAMETER CONDUIT SHALL BE THE MINIMUM SIZE USED.

OWNER, DEVELOPER, OR CONTRACTOR SHALL INSTALL CONDUIT WITH PULL ROPE. CONDUIT SIZE AND DEPTH, AND INSTALLATION DETAILS PER SERVING UTILITY REQUIREMENTS. OWNER SHALL FURNISH AN EASEMENT AS REQUIRED BY THE SERVING UTILITY.

5 TO 6 FOOT SIDEWALK

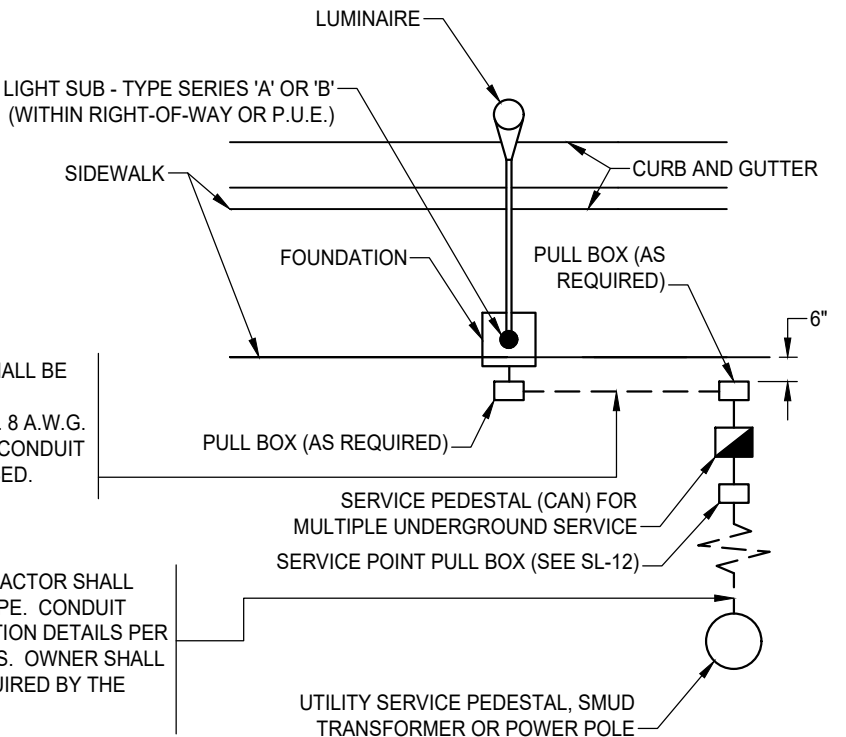

6 FOOT OR WIDER SIDEWALK

**NOTES:**

1. ALL CITY OWNED FACILITIES SHALL BE WITHIN RIGHT-OF-WAY (R/W) OR PUBLIC UTILITY EASEMENT (PUE).
2. SEE STANDARD DRAWING SL-12 FOR SERVICE POINT PULL BOX DETAILS AND WIRING DIAGRAM.
3. SEE STANDARD DRAWING SL-4 FOR PULL BOX DETAILS.
4. PHOTOCELLS SHALL BE INSTALLED ON THE TOP OF THE LUMINAIRE NEAREST THE SERVICE PEDESTAL OR SERVICE POINT.
5. THE SERVICING UTILITY WILL INSTALL AND MAINTAIN CONDUCTORS FROM THEIR TRANSFORMER, OR POWER POLE TO THE SERVICE POINT PULL BOX.
6. STREET LIGHT CIRCUITS SHALL HAVE A DEDICATED SERVICE METER AND SHALL NOT BE WIRED TO BYPASS THE METER.

|                    |     |              |            |
|--------------------|-----|--------------|------------|
| DATE<br>09/22/2007 |     | NOT TO SCALE |            |
| REVISION           | BY  | APPROVED     | DATE       |
| 01                 | STN | JRW          | 02/16/2021 |
|                    |     |              |            |
|                    |     |              |            |

CITY OF ELK GROVE - PUBLIC WORKS

**UNDERGROUND SERVICE  
INSTALLATION**

APPROVED BY:  
*Robert M. Mudgett*  
CITY ENGINEER      02/26/2021  
DATE



DRAWING NUMBER  
**SL - 7**

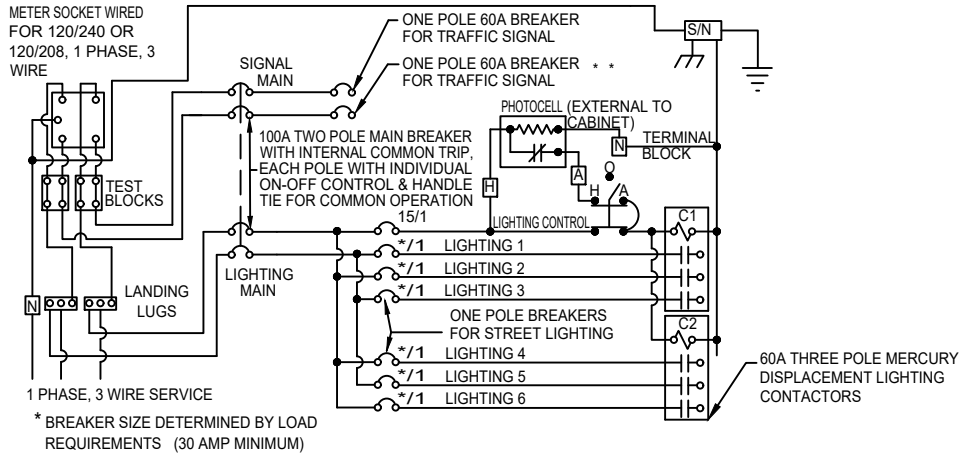
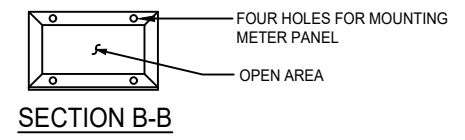
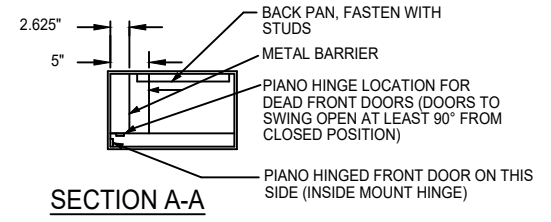
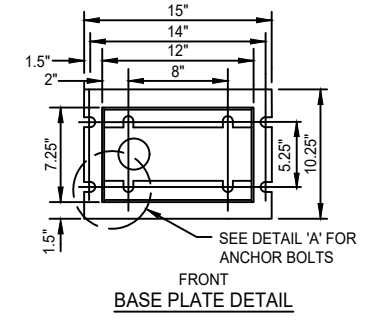
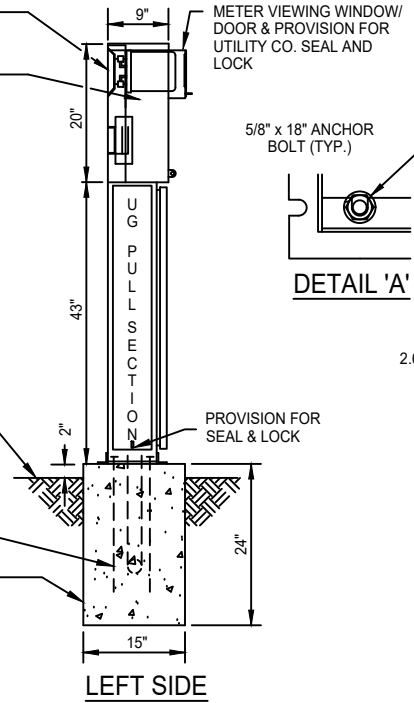
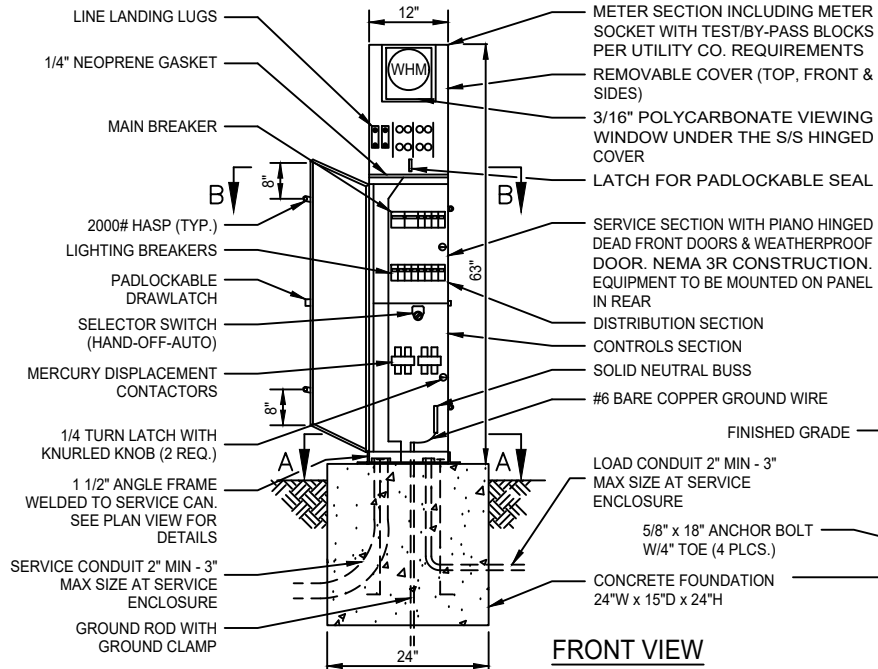

- NOTES:
- EXTERIOR SHALL BE 14 GAUGE #304D STAINLESS STEEL, INTERIOR DEAD FRONT PANEL AND BACK PAN SHALL BE 14 GAUGE STEEL, PAINTED WHITE. ENCLOSURE SHALL BE ELECTRICALLY WELDED AND REINFORCED WHERE REQUIRED.
  - CONSTRUCTION SHALL BE NEMA 3R AND 12, RAIN TIGHT AND DUST TIGHT.
  - ALL NUTS, BOLTS, SCREWS AND HINGES SHALL BE STAINLESS STEEL.
  - NUTS, BOLTS, AND SCREWS SHALL NOT BE USED ON THE OUTSIDE OF THE SERVICE ENCLOSURE.
  - PHENOLIC NAMEPLATES SHALL BE USED TO IDENTIFY ALL OPERATOR CONTROLS.
  - CONTROL WIRING SHALL BE MARKED AT BOTH ENDS BY PERMANENT WIRE MARKERS.
  - A PLASTIC COVERED WIRING DIAGRAM SHALL BE ATTACHED TO THE INSIDE OF THE FRONT DOOR.
  - SERVICE ENCLOSURE SHALL BE FACTORY WIRED AND CONFORM TO REQUIRED NEMA STANDARDS.
  - SERVICE ENCLOSURE SHALL BE U.L. LISTED AS INDUSTRIAL CONTROL PANELS U.L. 508 FILE NO. E62062.
  - WIRING BETWEEN CIRCUIT BREAKER AND CONTACTOR SHALL BE #6 THWN OR THHN MINIMUM.
  - SERVICE ENCLOSURE SHALL BE OF TWO-PIECE CONSTRUCTION.
  - THE WIRING SCHEMATIC DIAGRAM AS SHOWN IS FOR A 2-WIRE STREET LIGHTING SYSTEM. IF THE SERVICE ENCLOSURE WILL BE USED FOR A 3-WIRE STREET LIGHTING SYSTEM, THEN THE LIGHTING BREAKERS SHALL CONSIST OF 2-POLE BREAKERS WITH INTERNAL COMMON TRIP, EACH POLE WITH INDIVIDUAL ON-OFF CONTROL AND HANDLE TIE FOR COMMON OPERATION. FOR EACH 2-POLE BREAKER, THE CIRCUIT LOAD SHALL BE EQUALLY DIVIDED ACROSS THE LIGHTING MAIN.
  - SEE STANDARD SPECIFICATIONS FOR ADDITIONAL DETAILS.
  - DUAL METERS SHALL BE PROVIDED AND SHALL CONFORM TO CALTRANS STANDARD DRAWING ES-2F.
  - STREET LIGHT CIRCUITS SHALL HAVE A DEDICATED SERVICE METER AND SHALL NOT BE WIRED TO BYPASS THE METER.

**METERED SERVICE WIRING SCHEMATIC DIAGRAM**

\*\* MODIFY TRAFFIC SIGNAL BREAKER TO PROVIDE A 15 AMP. 120V, 1P CIRCUIT BREAKER FOR IISNS. MODIFY WIRINGS TO USE 60 AMP. LIGHTING CONTACTOR FOR IISNS.

|                    |     |              |            |
|--------------------|-----|--------------|------------|
| DATE<br>09/22/2007 |     | NOT TO SCALE |            |
| REVISION           | BY  | APPROVED     | DATE       |
| 01                 | STN | JRW          | 02/16/2021 |
|                    |     |              |            |
|                    |     |              |            |

CITY OF ELK GROVE - PUBLIC WORKS

**METERED SERVICE PEDESTAL (Can) (120/208V, 120/240V)**

APPROVED BY:  
*Paul Muddoch*  
CITY ENGINEER      02/26/2021  
DATE



DRAWING NUMBER  
**SL - 8**

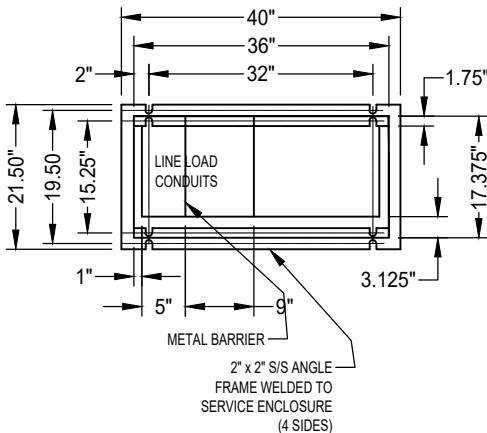
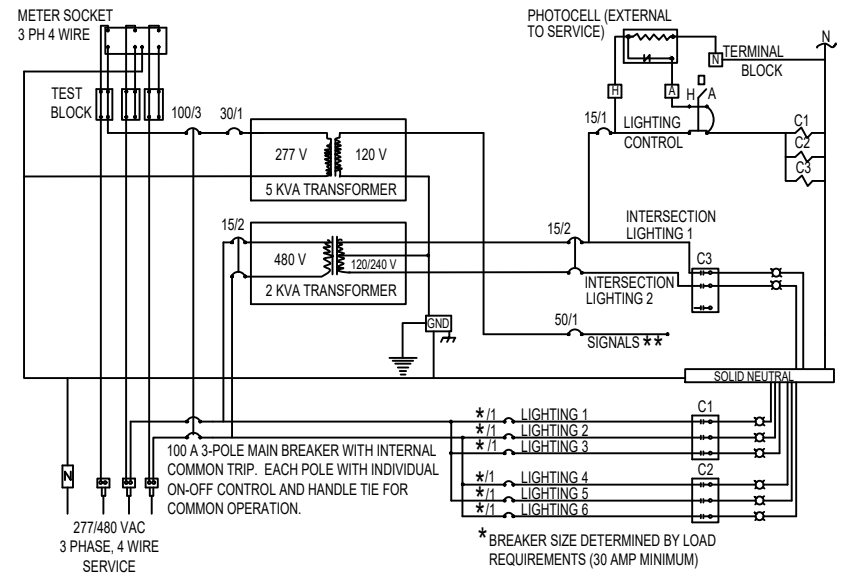
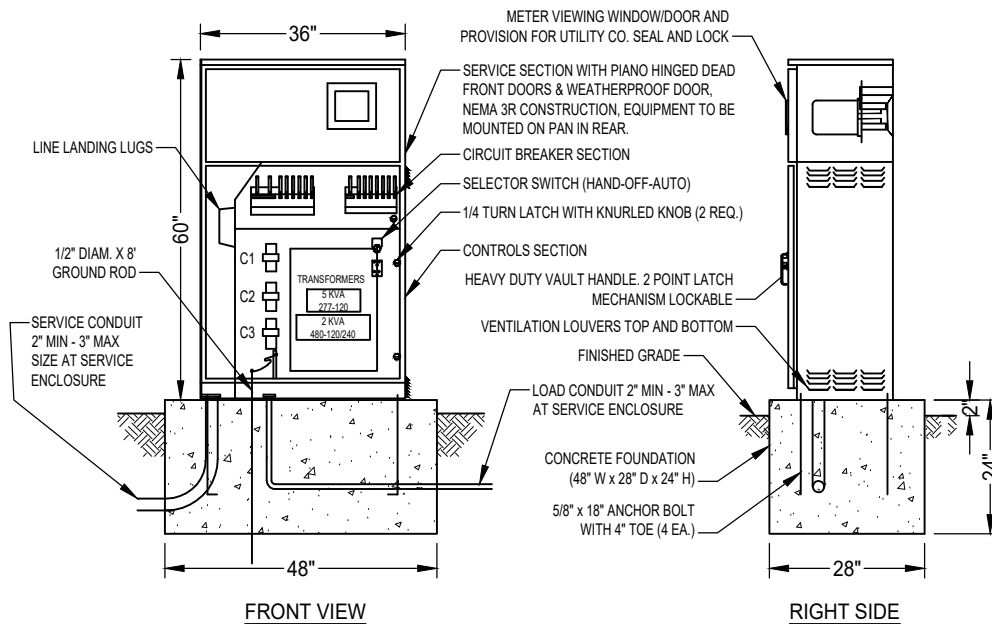

**NOTES:**

- EXTERIOR SHALL BE 14 GAUGE #304D STAINLESS STEEL, INTERIOR SHALL BE 14 GAUGE STEEL, PAINTED WHITE. ENCLOSURE SHALL BE ELECTRICALLY WELDED AND REINFORCED WHERE REQUIRED.
- CONSTRUCTION SHALL BE NEMA 3R AND 12, RAIN TIGHT AND DUST TIGHT.
- ALL NUTS, BOLTS, SCREWS AND HINGES SHALL BE STAINLESS STEEL.
- NUTS, BOLTS, AND SCREWS SHALL NOT BE USED ON THE OUTSIDE OF THE SERVICE ENCLOSURE.
- PHENOLIC NAMEPLATES SHALL BE USED TO IDENTIFY ALL OPERATION CONTROLS.
- CONTROL WIRING SHALL BE MARKED AT BOTH ENDS BY PERMANENT WIRE MARKERS.
- A PLASTIC COVERED WIRING DIAGRAM SHALL BE ATTACHED TO THE INSIDE OF THE FRONT DOOR.
- SERVICE ENCLOSURE SHALL BE FACTORY WIRED AND CONFORM TO REQUIRED NEMA STANDARDS.
- SERVICE ENCLOSURE SHALL BE U.L. LISTED AS INDUSTRIAL CONTROL PANELS U.L. 508 FILE NO. E62062.
- WIRING BETWEEN CIRCUIT BREAKER AND CONTACTOR SHALL BE #6 THWN OR THHN MINIMUM.
- SIZE OF TRANSFORMER FOR SIGNALS SHALL BE 5 KVA. SIZE OF TRANSFORMER FOR 120 V INTERSECTION SHALL BE 2 KVA.
- WHEN CHANGING VOLTAGE ON A RETROFIT PROJECT WHERE A NEW SERVICE ENCLOSURE WITH A STEP-DOWN TRANSFORMER IS REQUIRED, THE NEW SERVICE ENCLOSURE THE NEW SERVICE ENCLOSURE SHALL BE PLACED BETWEEN THE SERVICE POINT AND THE OLD SERVICE ENCLOSURE LOCATION WITHIN THE CITY R/W. VOLTAGE OUTPUT FROM THE NEW SERVICE ENCLOSURE MAY BE CONNECTED INTO THE EXISTING CONDUIT SYSTEM.
- THE WIRING SCHEMATIC DIAGRAM AS SHOWN IS FOR A 2-WIRE STREET LIGHTING SYSTEM. IF THE SERVICE ENCLOSURE WILL BE USED FOR A 3-WIRE STREET LIGHTING SYSTEM, THEN THE LIGHTING BREAKERS SHALL CONSIST OF 2-POLE BREAKERS WITH INTERNAL COMMON TRIP, EACH POLE WITH INDIVIDUAL ON-OFF CONTROL AND HANDLE TIE FOR COMMON OPERATION. FOR EACH 2-POLE BREAKER, THE CIRCUIT LOAD SHALL BE EQUALLY DIVIDED ACROSS THE LIGHTING MAIN.
- SEE STANDARD SPECIFICATIONS FOR ADDITIONAL DETAILS.
- DUAL METERS SHALL BE PROVIDED AND SHALL CONFORM TO CALTRANS STANDARD DRAWING ES-2F.
- STREET LIGHT CIRCUITS SHALL HAVE A DEDICATED SERVICE METER AND SHALL NOT BE WIRED TO BYPASS THE METER.

\* BREAKER SIZE DETERMINED BY LOAD REQUIREMENTS (30 AMP MINIMUM)

\*\* PROVIDE A 15 AMP, 120V, 1P CIRCUIT BREAKER FOR IISNS. MODIFY WIRINGS TO USE LIGHTING CONTACTOR FOR IISNS.

|                    |     |              |            |
|--------------------|-----|--------------|------------|
| DATE<br>09/22/2007 |     | NOT TO SCALE |            |
| REVISION           | BY  | APPROVED     | DATE       |
| 01                 | STN | JRW          | 02/16/2021 |
|                    |     |              |            |
|                    |     |              |            |

**CITY OF ELK GROVE - PUBLIC WORKS**

**METERED SERVICE PEDESTAL (Can)  
WITH STEP-DOWN TRANSFORMER  
(277/480V TO 120/240V)**

APPROVED BY:  
*Paul M. Mueloch*  
CITY ENGINEER

02/26/2021  
DATE

DRAWING NUMBER  
**SL - 9**



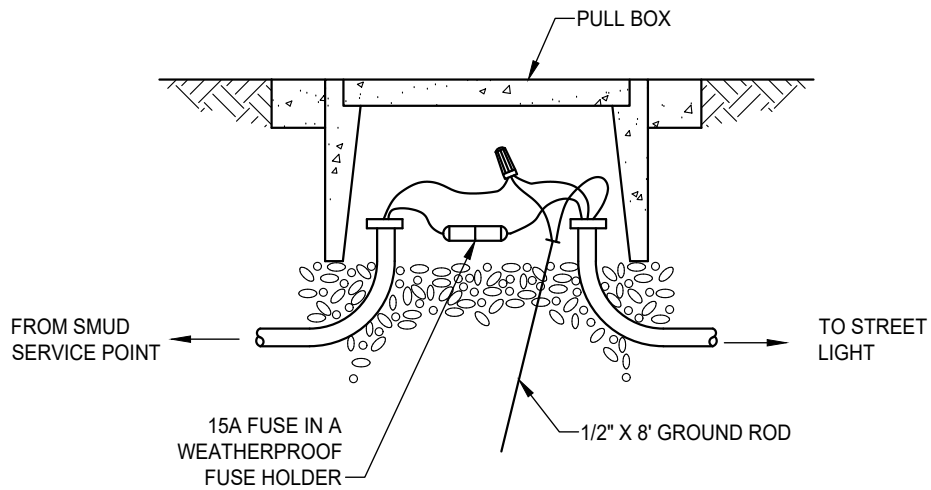

SERVICE POINT PULL BOX DETAILS

| LAMP WATTAGE     | ELECTROLIER FUSE SIZE |
|------------------|-----------------------|
| 115 WATT OR LESS | 2 AMP                 |

NOTES:

1. FUSE SHALL BE A MIDGET FERRULE TYPE. RATED AT 600 VOLTS.
2. ATTACH GROUND CONDUCTOR TO THE ELECTROLIER.
3. ALL PULL BOXES SHALL HAVE PROVISIONS FOR LOCKING.

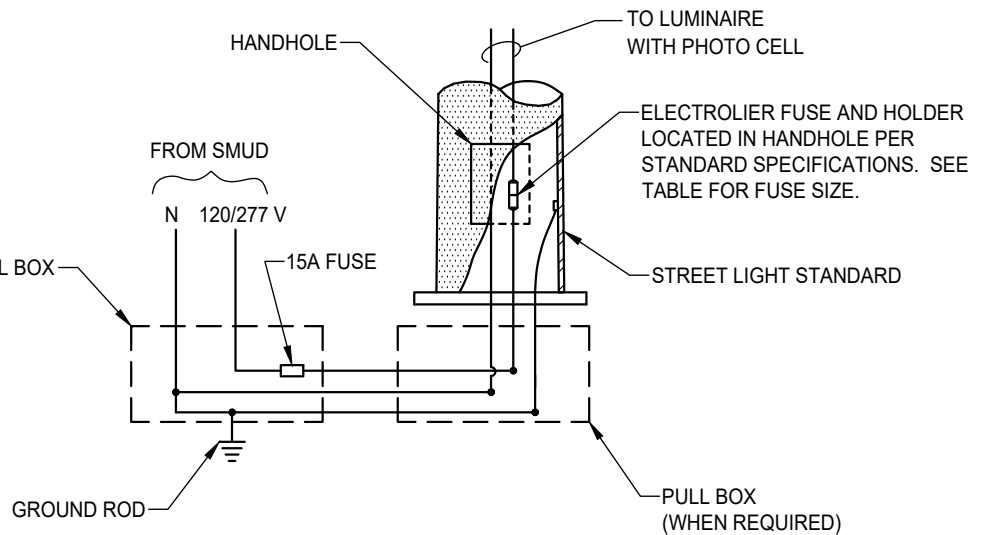

WIRING DIAGRAM

|                     |     |              |            |
|---------------------|-----|--------------|------------|
| DATE:<br>09/22/2007 |     | NOT TO SCALE |            |
| REVISION            | BY  | APPROVED     | DATE       |
| 1                   | SJB | SMA          | 03-25-2024 |
|                     |     |              |            |
|                     |     |              |            |

CITY OF ELK GROVE - PUBLIC WORKS

**IN-LINE FUSE REQUIREMENTS**

APPROVED BY:

*[Signature]* 05-28-2024

CITY ENGINEER

DATE



DRAWING NUMBER

**SL - 12**

# TYPICAL VOLTAGE DROP CALCULATION FOR 2 - WIRE SYSTEM

$$\text{VOLTAGE DROP (COPPER CONDUCTOR)} = \frac{D \times A \times N \times 22}{\text{CIRCULAR MILS}}$$

**D** = Length of section, in feet.

**A** = Line operating amperes drawn by one light.

**N** = Number of lights in the circuit beyond the section.

| WIRE SIZE (AWG) | AREA (Circular Mils) |
|-----------------|----------------------|
| 14              | 4,110                |
| 12              | 6,530                |
| 10              | 10,380               |
| 8               | 16,510               |
| 6               | 26,250               |
| 4               | 41,740               |

|  |
|--|
| <b>Driver Maximum Input Amps for Light Emitting Diode (LED) Luminaires (At 115 Volts)</b><br><br>All Fixtures: 1.25 Amps |
|--|

### TYPICAL MULTIPLE STREET LIGHTING SYSTEM

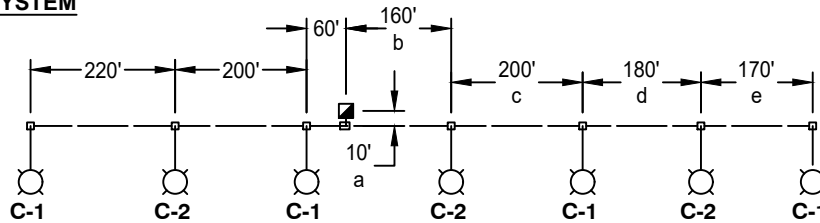

#### EXAMPLE CALCULATION:

**FIND TOTAL VOLTAGE DROP IN CIRCUIT #1:**  
(115 volt system)

#### NOTE:

Dimension "a" is the distance between the service can and the adjacent load pull box. Use "a"=10' for standard installations where the load pull box is immediately adjacent to the service can.

#### Voltage drop calculations

$$\text{Section a} = \frac{10 (1.25 \times 4) (22)}{10,380} = 0.11$$

$$\text{Section b + c} = \frac{360 (1.25 \times 2) (22)}{10,380} = 1.91$$

$$\text{Section d + e} = \frac{350 (1.25 \times 1) (22)}{10,380} = 0.93$$

$$\text{TOTAL VOLTAGE DROP} = 2.95$$

#### LEGEND

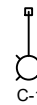

**115W Light Emitting Diode Luminaire**

**Circuit #1**



**Service Can**

**Conduit with #10 AWG Conductors**

#### NOTES:

- Design must be based on a two (2) wire system, even though three (3) wires (with a single common wire) are actually used.
- Maximum voltage drop allowed in 115 volt system = 8.05 volts.

|                    |     |              |            |
|--------------------|-----|--------------|------------|
| DATE<br>09-22-2017 |     | NOT TO SCALE |            |
| REVISION           | BY  | APPROVED     | DATE       |
| 01                 | STN | SA           | 06-20-2023 |
|                    |     |              |            |
|                    |     |              |            |

CITY OF ELK GROVE - PUBLIC WORKS

## 2 - WIRE STREET LIGHT SYSTEM WIRE SIZE AND VOLTAGE DROP CALCULATION

APPROVED BY:

*Jeffrey B. Wan* 06-21-2023  
CITY ENGINEER DATE



DRAWING NUMBER

**SL - 13**

# TYPICAL VOLTAGE DROP CALCULATION FOR 3 - WIRE SYSTEM

$$\text{VOLTAGE DROP (COPPER CONDUCTOR)} = \frac{D \times A \times N \times 11}{\text{CIRCULAR MILS}}$$

**D** = Length of section, in feet.

**A** = Line operating amperes drawn by one light.

**N** = Number of lights in the circuit beyond the section.

| WIRE SIZE (AWG) | AREA (Circular Mils) |
|-----------------|----------------------|
| 14              | 4,110                |
| 12              | 6,530                |
| 10              | 10,380               |
| 8               | 16,510               |
| 6               | 26,250               |
| 4               | 41,740               |

|  |
|--|
| Driver Maximum Input Amps for Light Emitting Diode (LED) Luminaires (At 115 Volts) |
| All Fixtures: 1.25 Amps  |

### TYPICAL MULTIPLE STREET LIGHTING SYSTEM

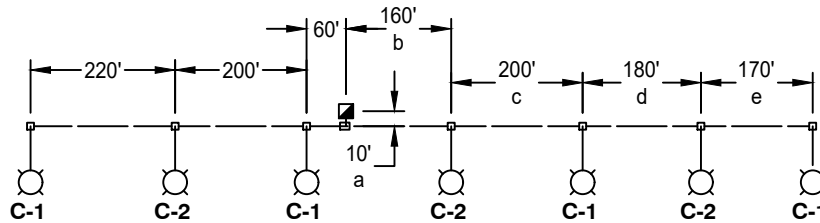





**EXAMPLE CALCULATION:**  
FIND TOTAL VOLTAGE DROP IN CIRCUIT #1:  
(115 volt system)

**NOTE:**

Dimension "a" is the distance between the service can and the adjacent load pull box. Use "a"=10' for standard installations where the load pull box is immediately adjacent to the service can.

**LEGEND**

-  115W Light Emitting Diode Luminaire
-  Circuit #1
-  Service Can
-  Conduit with #12 AWG Conductors

**Voltage drop calculations**

Section a =  $\frac{10 (1.25 \times 4) (11)}{6,530} = 0.08$

Section b + c =  $\frac{360 (1.25 \times 2) (11)}{6,530} = 1.52$

Section d + e =  $\frac{350 (1.25 \times 1) (11)}{6,530} = 0.74$

**TOTAL VOLTAGE DROP = 2.34**

**NOTES:**

- Maximum voltage drop allowed in 115 volt system = 6.90 volts.

|                    |     |              |            |
|--------------------|-----|--------------|------------|
| DATE<br>09-22-2017 |     | NOT TO SCALE |            |
| REVISION           | BY  | APPROVED     | DATE       |
| 01                 | STN | SA           | 06-20-2023 |
|                    |     |              |            |
|                    |     |              |            |

CITY OF ELK GROVE - PUBLIC WORKS

---

**3 - WIRE STREET LIGHT SYSTEM  
WIRE SIZE AND VOLTAGE DROP  
CALCULATION**

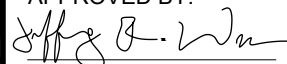
APPROVED BY:  
 06-21-2023  
CITY ENGINEER DATE

---

DRAWING NUMBER  
**SL - 14**



CONDUIT SIZING

| CONDUCTOR                        | EQUIVALENT NUMBER OF #14 AWG CONDUCTORS FOR USE IN CONDUIT SIZING |
|----------------------------------|---|
| #12 CONDUCTOR                    | 1.2   |
| #10 CONDUCTOR                    | 1.5   |
| #8 CONDUCTOR                     | 2.3   |
| #6 CONDUCTOR                     | 3   |
| #4 CONDUCTOR                     | 4   |
| #2 CONDUCTOR                     | 5.3   |
| #0 CONDUCTOR                     | 11.5  |
| INTERCONNECT CABLE               | 18  |
| DETECTOR LEAD-IN CABLE           | 2.5   |
| EMERGENCY VEHICLE DETECTOR CABLE | 2   |

| CONDUIT SIZE                         | 2" | 2.5" | 3" | 3.5" | 4"  |
|--------------------------------------|----|------|----|------|-----|
| MAXIMUM NUMBER OF #14 AWG CONDUCTORS | 31 | 44   | 69 | 91   | 113 |

NOTE: MINIMUM SIZE FOR NEW CONDUITS IS 2.0".

SERVICE WIRE MAXIMUM LENGTHS FOR TRAFFIC SIGNALS

CIRCUIT BREAKER SIZING

| CONDUCTOR SIZE (AWG) | MAXIMUM CIRCUIT BREAKER AMPERAGE |
|----------------------|----------------------------------|
| #2                   | 100                              |
| #4                   | 80                               |
| #6                   | 50                               |
| #8                   | 40                               |
| #10                  | 30                               |

| WIRE SIZE | LENGTH |
|-----------|--------|
| #0        | 576'   |
| #2        | 360'   |
| #4        | 224'   |

NOTE:

1. THE BREAKER SIZE SHALL BE DETERMINED BY THE LOAD REQUIREMENTS. MINIMUM BREAKER SIZE IS 15 AMPS.

|                     |     |              |            |
|---------------------|-----|--------------|------------|
| DATE:<br>09/22/2017 |     | NOT TO SCALE |            |
| REVISION            | BY  | APPROVED     | DATE       |
| 1                   | SJB | SMA          | 03-25-2024 |
|                     |     |              |            |
|                     |     |              |            |

CITY OF ELK GROVE - PUBLIC WORKS

**CONDUIT, SERVICE WIRE AND  
BREAKER SIZING**

APPROVED BY:  05-28-2024  
CITY ENGINEER DATE



DRAWING NUMBER

**SL - 15**



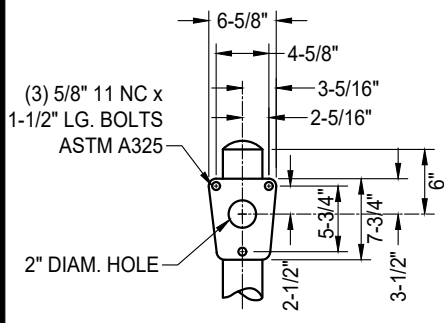

LUMINAIRE ARM DETAILS

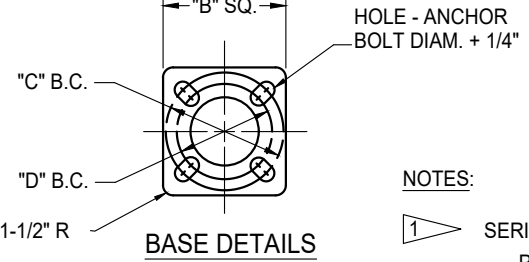
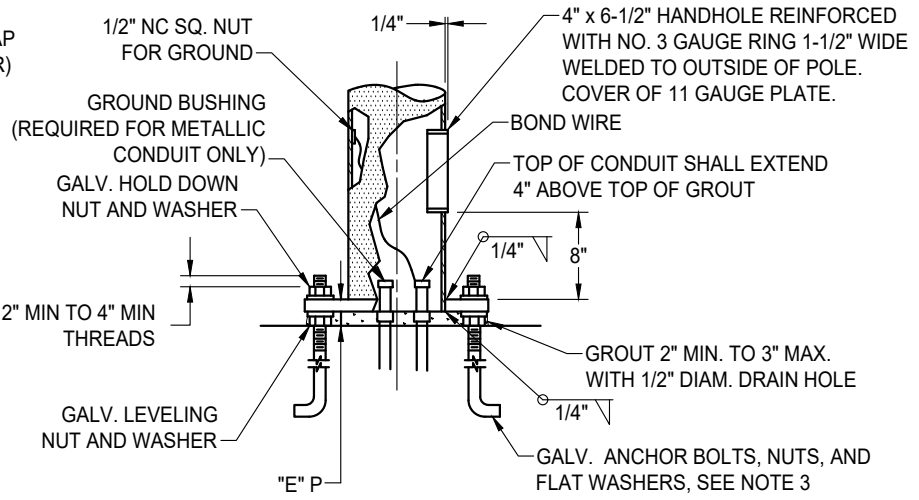
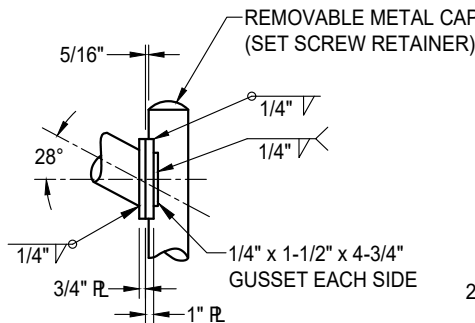

- NOTES:
- SERIES 'A' NUMBERING PROCEDURE  
 POLE SIZE 'A' → A-286-8 → LUMINAIRE ARM SIZE 'F'  
 (STANDARD UNLESS OTHERWISE SPECIFIED)
  - STANDARD SHALL BE INSTALLED SO HANDHOLE FACES THE STREET.
  - ANCHOR BOLT SIZES SHALL BE PURSUANT TO THE POLE MANUFACTURER'S DESIGN REQUIREMENTS, WHICH SHALL BE IN ACCORDANCE WITH AASHTO "STANDARD SPECIFICATIONS FOR STRUCTURAL SUPPORTS FOR HIGHWAY SIGNS, LUMINAIRES, AND TRAFFIC SIGNALS."

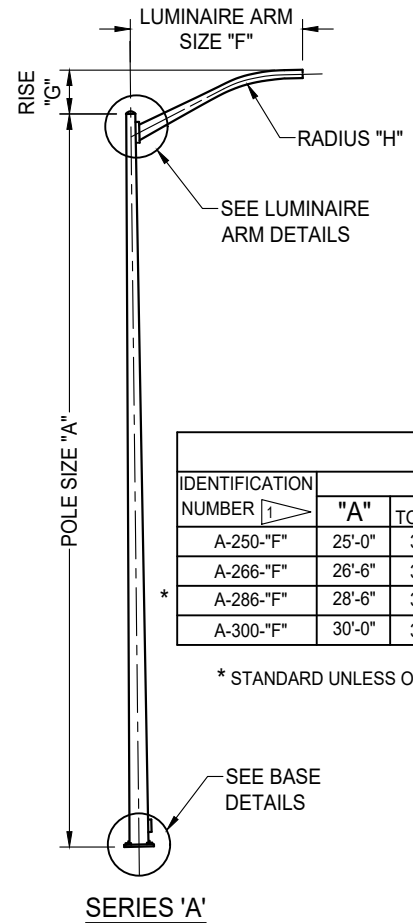

| FOUNDATION DIMENSIONS |                  |             |
|-----------------------|------------------|-------------|
|                       | SQUARE           | ROUND       |
| SERIES 'A'            | 2'6" x 2'6" x 5' | 2'6" x 6'6" |

| LUMINAIRE ARM DATA |        |          |    |       |        |  |
|--------------------|--------|----------|----|-------|--------|--|
| "F"                | END OD | BASE OD  | GA | "G"   | "H"    |  |
| 6'-0"              | 2-3/8" | 3-3/8"   | 10 | 1'-6" | 7'-5"  |  |
| * 8'-0"            | 2-3/8" | 3-11/16" | 10 | 2'-3" | 7'-5"  |  |
| 10'-0"             | 2-3/8" | 3-7/8"   | 10 | 2'-6" | 13'-3" |  |
| 12'-0"             | 2-3/8" | 4-5/16"  | 10 | 3'-9" | 13'-3" |  |
| 15'-0"             | 2-3/8" | 4-3/4"   | 10 | 4'-3" | 13'-3" |  |
| 18'-0"             | 2-3/8" | 4-3/4"   | 10 | 5'-3" | 13'-3" |  |

| 'A' SERIES            |           |        |         |    |                 |         |     |     |              |
|-----------------------|-----------|--------|---------|----|-----------------|---------|-----|-----|--------------|
| IDENTIFICATION NUMBER | POLE DATA |        |         |    | BASE PLATE DATA |         |     |     | ANCHOR BOLTS |
|                       | "A"       | TOP OD | BASE OD | GA | "B"             | "C"     | "D" | "E" |              |
| A-250-"F"             | 25'-0"    | 3-7/8" | 7-5/16" | 11 | 12"             | 11-1/2" | 11" | 1"  | SEE NOTE 3   |
| A-266-"F"             | 26'-6"    | 3-7/8" | 7-1/2"  | 11 | 12"             | 11-1/2" | 11" | 1"  |              |
| * A-286-"F"           | 28'-6"    | 3-7/8" | 7-3/4"  | 11 | 12"             | 11-1/2" | 11" | 1"  |              |
| A-300-"F"             | 30'-0"    | 3-7/8" | 8"      | 11 | 12"             | 11-1/2" | 11" | 1"  |              |

\* STANDARD UNLESS OTHERWISE SPECIFIED

|                    |     |              |            |
|--------------------|-----|--------------|------------|
| DATE<br>09/22/2007 |     | NOT TO SCALE |            |
| REVISION           | BY  | APPROVED     | DATE       |
| 01                 | STN | JRW          | 02/16/2021 |
|                    |     |              |            |
|                    |     |              |            |

CITY OF ELK GROVE - PUBLIC WORKS

**COMMON TYPE ELECTROLIER (SERIES 'A')**

APPROVED BY:  
  
 CITY ENGINEER      02/26/2021      DATE

DRAWING NUMBER  
**SL - 20**

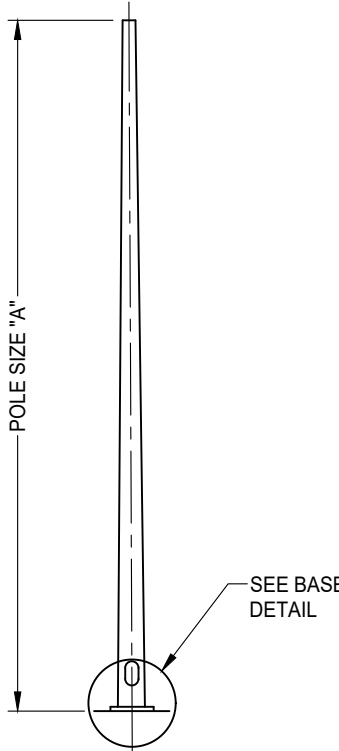
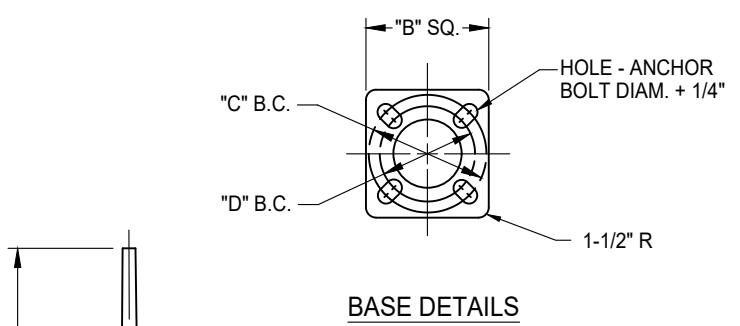

| FOUNDATION DIMENSIONS |              |                              |
|-----------------------|--------------|------------------------------|
|                       | SQUARE       | ROUND                        |
| SERIES 'B'            | 2' x 2' x 4' | 2'6" x 3'6"<br>or<br>2' x 4' |

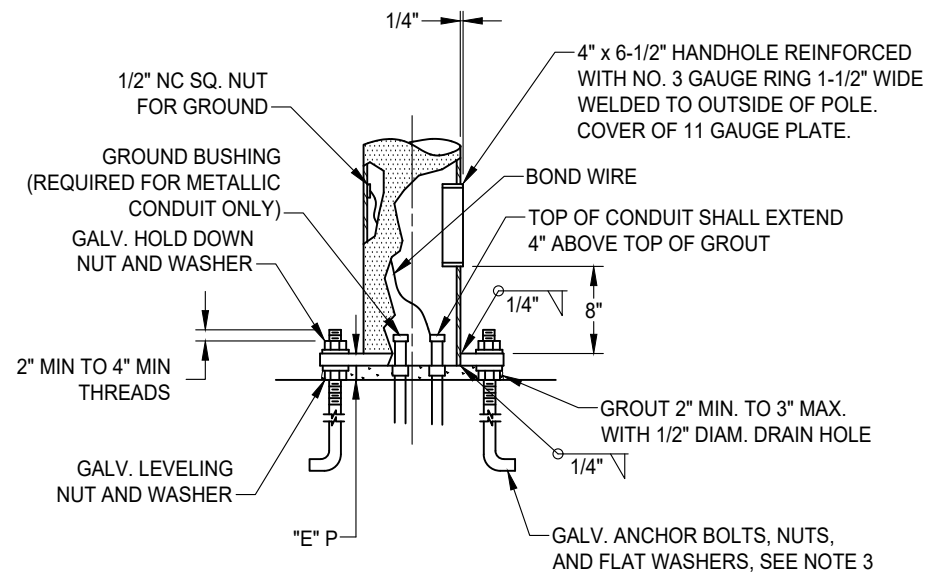

| 'B' SERIES |        |         |       |       |                 |        |     |     |              |
|------------|--------|---------|-------|-------|-----------------|--------|-----|-----|--------------|
| POLE DATA  |        |         |       |       | BASE PLATE DATA |        |     |     | ANCHOR BOLTS |
| "A"        | TOP OD | BASE OD |       | GAUGE | "B"             | "C"    | "D" | "E" |              |
|            |        | MIN     | MAX   |       |                 |        |     |     |              |
| 20'-0"     | 2-7/8" | 5.61"   | 5.85" | 10    | 10"             | 9-1/2" | 9"  | 1"  | NOTE 3       |

- NOTES:**
- STANDARD SHALL BE INSTALLED SO HANDHOLE FACES THE STREET.
  - FOR USE IN ALL IN-FILL PROJECTS EAST OF HIGHWAY 99 OR NORTH OF ELK GROVE BLVD AND WEST OF HIGHWAY 99.
  - ANCHOR BOLTS SIZES SHALL BE PURSUANT TO THE POLE MANUFACTURER'S DESIGN REQUIREMENTS, WHICH SHALL BE IN ACCORDANCE WITH AASHTO "STANDARD SPECIFICATIONS FOR STRUCTURAL SUPPORTS FOR HIGHWAY SIGNS, LUMINAIRES, AND TRAFFIC SIGNALS."

|                    |     |              |            |
|--------------------|-----|--------------|------------|
| DATE<br>09/22/2007 |     | NOT TO SCALE |            |
| REVISION           | BY  | APPROVED     | DATE       |
| 01                 | STN | JRW          | 02/16/2021 |
|                    |     |              |            |
|                    |     |              |            |

CITY OF ELK GROVE - PUBLIC WORKS

**COMMON TYPE ELECTROLIER  
(SERIES 'B')**

APPROVED BY:

*Paul M. Mueloch* 02/26/2021

CITY ENGINEER DATE

DRAWING NUMBER

**SL - 22**



| STREET CLASSIFICATION | RIGHT - OF - WAY WIDTH | STREET LIGHT SUB-TYPE (SERIES) | STANDARD MOUNTING HEIGHT | MAXIMUM SPACING** (ONE SIDE ONLY) |
|-----------------------|------------------------|--------------------------------|--------------------------|-----------------------------------|
| MAJOR ARTERIAL        | 96'                    | A                              | 30' - 9"                 | 220'                              |
| MINOR ARTERIAL        | 74'                    | A                              | 30' - 9"                 | 220'                              |
|                       |                        |                                |                          | MAXIMUM SPACING** (TWO-SIDES)     |
| COLLECTOR             | 50'                    | B                              | 21'                      | 180'                              |
| PRIMARY RESIDENTIAL   | 40'                    | B                              | 21'                      | 200'                              |
| MINOR RESIDENTIAL     | 44'                    | B                              | 21'                      | 240'                              |

**NOTES:**

1. WATTAGE AND MODEL NUMBER FOR LIGHT EMITTING DIODE (LED) LAMP SHALL BE SPECIFIED ON THE PLANS. EQUIPMENT SHALL CONFORM TO CITY OF ELK GROVE APPROVED EQUIPMENT LIST.
2. ILLUMINATION SHALL CONFORM TO STANDARD DRAWING SL-2.
3. SEE SECTION 5-8D OF THE CITY IMPROVEMENT STANDARDS, "SPACING," FOR DEFINITIONS OF ONE-SIDE AND TWO-SIDE SPACING.
- \*4. SINGLE FAMILY AND DUPLEX FAMILY ZONING SHALL USE SERIES 'B' STREET LIGHT, 21' MOUNTING HEIGHT, AND 180' SPACING.
- \*\*5. MAXIMUM SPACING MAY BE ADJUSTED AS LONG AS ILLUMINATION CRITERIA ARE MET WITH APPROVAL OF THE ENGINEER.

|                    |     |              |            |
|--------------------|-----|--------------|------------|
| DATE<br>09/22/2017 |     | NOT TO SCALE |            |
| REVISION           | BY  | APPROVED     | DATE       |
| 1                  | SJB | SMA          | 03-07-2025 |
|                    |     |              |            |
|                    |     |              |            |

CITY OF ELK GROVE - PUBLIC WORKS

**COMMON TYPE STREET LIGHT POLE  
SPACING GUIDE  
(SERIES 'A' / SERIES 'B')**

APPROVED BY: \_\_\_\_\_  
CITY ENGINEER      DATE 03-12-2025

 DRAWING NUMBER  
**SL - 24**

# STREET LIGHT PLACEMENT ON MAJOR ARTERIAL AND MINOR ARTERIAL STREETS (96' AND 74' STREETS)

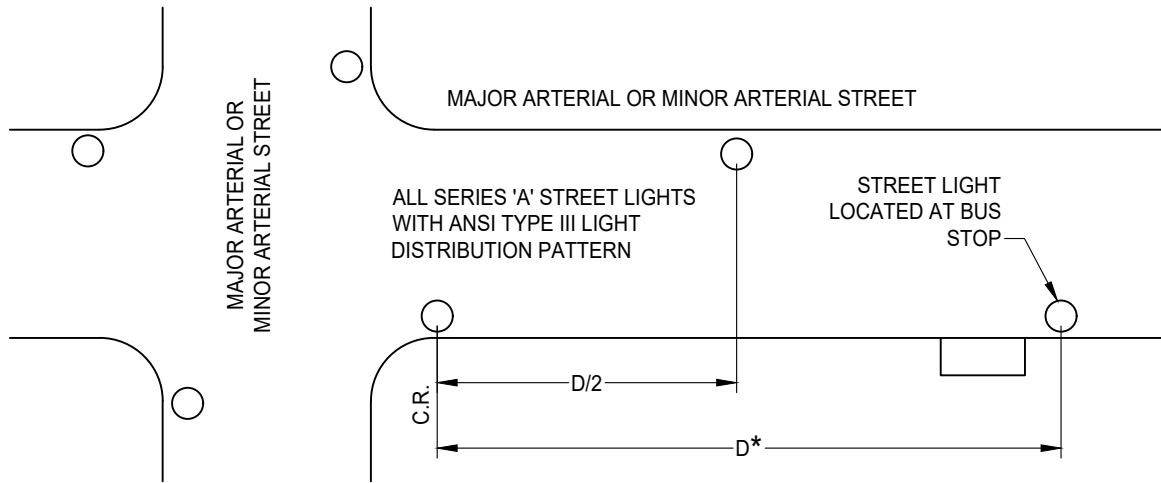

\*SEE STANDARD DRAWING SL-24

D = 180' FOR 130' STREETS

D = 220' FOR 74' STREETS AND 96' STREETS

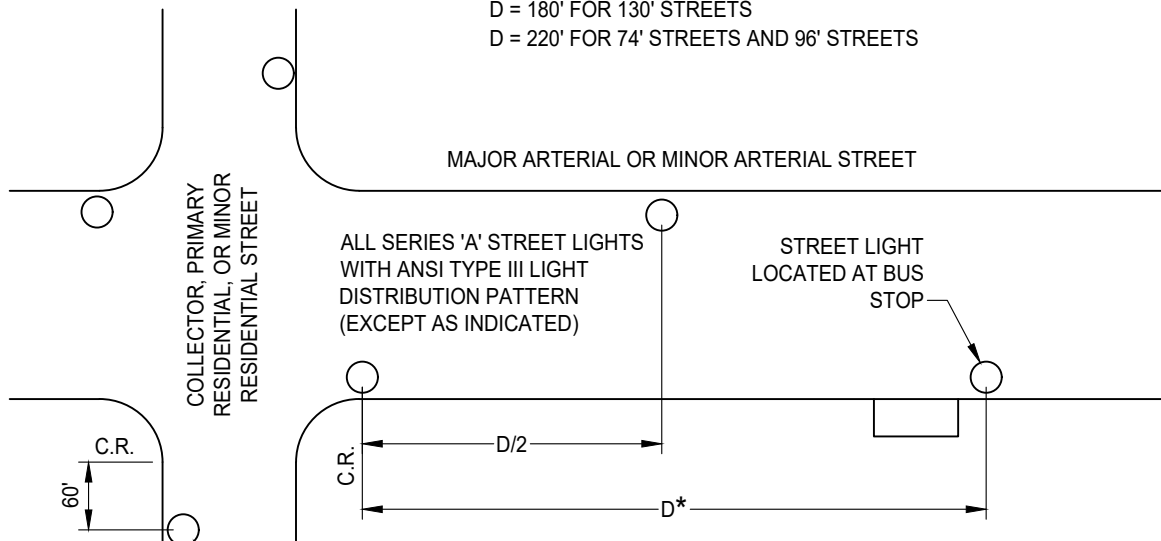

IN ACCORDANCE WITH STREET CLASSIFICATION,  
SERIES 'A' OR SERIES 'B' STREET LIGHT WITH ANSI  
TYPE III LIGHT DISTRIBUTION PATTERN.  
(SEE STANDARD DRAWINGS SL-2 AND SL-24)

|                    |     |              |            |
|--------------------|-----|--------------|------------|
| DATE<br>09/22/2017 |     | NOT TO SCALE |            |
| REVISION           | BY  | APPROVED     | DATE       |
| 1                  | SJB | SMA          | 03-07-2025 |
|                    |     |              |            |
|                    |     |              |            |

CITY OF ELK GROVE - PUBLIC WORKS

**COMMON TYPE TYPICAL LOCATIONS  
ARTERIAL STREETS  
(SERIES 'A'/ SERIES 'B')**

APPROVED BY: \_\_\_\_\_  
CITY ENGINEER

03-12-2025  
DATE

DRAWING NUMBER  
**SL - 25**



**STREET LIGHT PLACEMENT  
ON COLLECTOR, PRIMARY RESIDENTIAL, AND  
MINOR RESIDENTIAL STREETS  
(ALL STREETS OTHER THAN 96' AND 74' STREETS)**

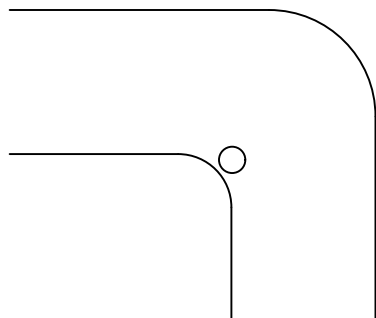
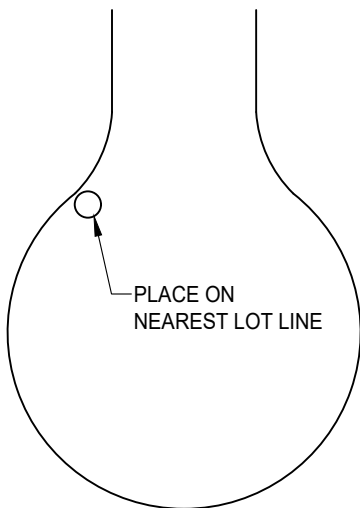
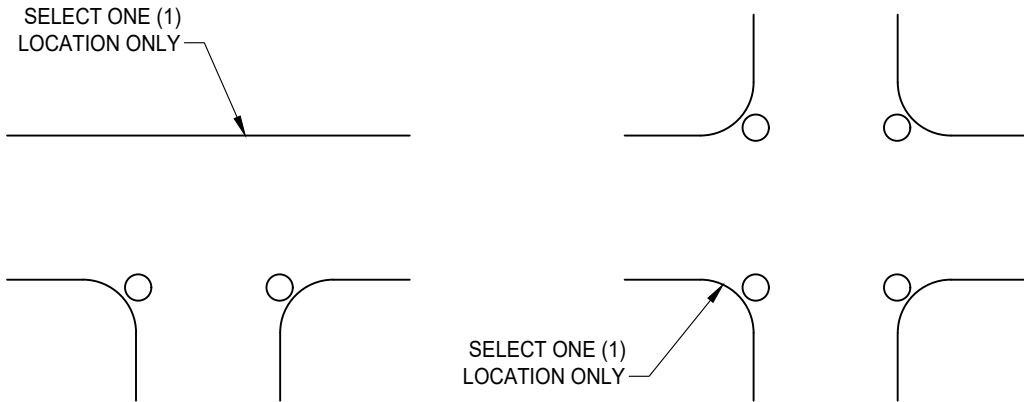

**NOTE:**

1. IN ACCORDANCE WITH STREET CLASSIFICATIONS, ALL ARE SERIES 'A' OR SERIES 'B' STREET LIGHTS WITH ANSI TYPE III LIGHT DISTRIBUTIONS PATTERN. SEE STANDARD DRAWINGS SL-2 AND SL-24

|                     |     |              |            |
|---------------------|-----|--------------|------------|
| DATE:<br>09/22/2017 |     | NOT TO SCALE |            |
| REVISION            | BY  | APPROVED     | DATE       |
| 1                   | SJB | SMA          | 03-07-2025 |
|                     |     |              |            |
|                     |     |              |            |

**CITY OF ELK GROVE - PUBLIC WORKS**

**COMMON TYPE TYPICAL LOCATIONS  
COLLECTOR AND RESIDENTIAL STREETS  
(SERIES 'A' / SERIES 'B')**

APPROVED BY: \_\_\_\_\_ 03-12-2025  
CITY ENGINEER DATE

DRAWING NUMBER  
**SL - 26**



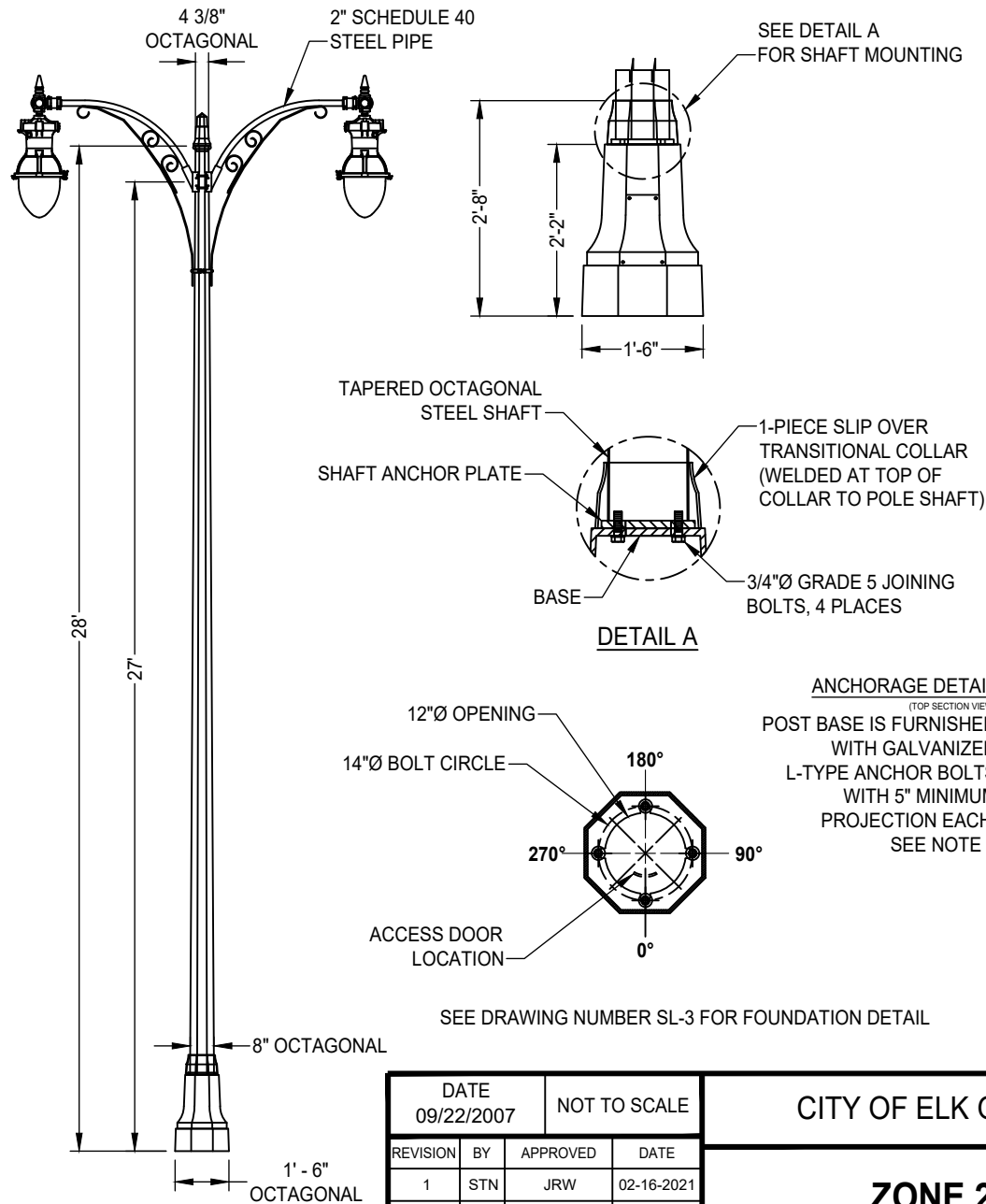

**APPLICATION:**

WIDE MEDIANS ON ARTERIALS AND THOROUGHFARES

**SPECIFICATIONS:**

**POST BASE**

THE BASE SHALL BE CAST IRON CONSTRUCTION WITH A TAPERED AND STEPPED OCTAGONAL PATTERN. A 1-PIECE SLIP OVER TRANSITION COLLAR COVERS THE BASE OF THE SHAFT. A DOOR IS LOCATED IN THE BASE FOR ANCHORAGE AND WIRING ACCESS. A GROUND SCREW (5/8") SHALL BE PROVIDED INSIDE THE BASE, OPPOSITE THE ACCESS DOOR.

**POST SHAFT**

THE POST SHAFT SHALL BE 11-GAUGE STEEL WITH A STEEL PLATE FOR MOUNTING TO THE BASE. THE OCTAGONAL SHAFT TAPERS FROM 8" (FLAT TO FLAT) AT THE BOTTOM TO 4-3/8" AT THE TOP, WITH A DECORATIVE OCTAGONAL FINIAL.

**CROSSARM**

THE CLAMP ON CROSSARM SHALL BE STEEL PIPE CONSTRUCTION WITH FLAT BAR SCROLLS AND 1-1/2" X 1/2" FLAT BAR CLAMP-ON BRACE. A SLEEVE GASKET SHALL BE INSTALLED TO PREVENT ARM MOVEMENT. ARMS SHALL HAVE A 2" PIPE SLEEVE FOR LUMINAIRE MOUNTING. THE CROSSARM MEASURES 52" FROM POST TO LUMINAIRE CENTERS. A LUMINAIRE LEVELING FITTER SHALL BE MOUNTED TO THE END OF THE PIPE ARM FOR LUMINAIRE MOUNTING. FIXTURE MOUNT TO CROSSARM SHALL BE HOLOPHANE WEST LIBERTY STYLE, QSM, OR EQUIVALENT. THREADED FIXTURE MOUNTS SHALL NOT BE ALLOWED.

**FINISH**

THE POST SHALL BE SHIPPED FINISHED WITH A STANDARD BLACK POWDER COAT FINISH.

**NOTES:**

1. ALL HARDWARE STAINLESS STEEL. ALL EXTERIOR HARDWARE TAMPER RESISTANT. BASE AND SHAFT TO BE SHIPPED AS A ONE-PIECE UNIT.
2. POLES AND LIGHTING EQUIPMENT SHALL CONFORM TO CITY OF ELK GROVE AUTHORIZED MATERIALS LIST
3. ANCHOR BOLT SIZES SHALL BE PURSUANT TO THE POLE MANUFACTURER'S DESIGN REQUIREMENTS, WHICH SHALL BE IN ACCORDANCE WITH AASHTO "STANDARD SPECIFICATIONS FOR STRUCTURAL SUPPORTS FOR HIGHWAY SIGNS, LUMINAIRES, AND TRAFFIC SIGNALS."

|                    |     |              |            |
|--------------------|-----|--------------|------------|
| DATE<br>09/22/2007 |     | NOT TO SCALE |            |
| REVISION           | BY  | APPROVED     | DATE       |
| 1                  | STN | JRW          | 02-16-2021 |
| 2                  | SJB | SMA          | 06-18-2025 |
|                    |     |              |            |
|                    |     |              |            |

CITY OF ELK GROVE - PUBLIC WORKS

APPROVED BY:

*[Signature]* 06-20-2025

CITY ENGINEER

DATE

**ZONE 2 ELECTROLIER  
(DUAL ARM)**



DRAWING NUMBER

**SL - 30**

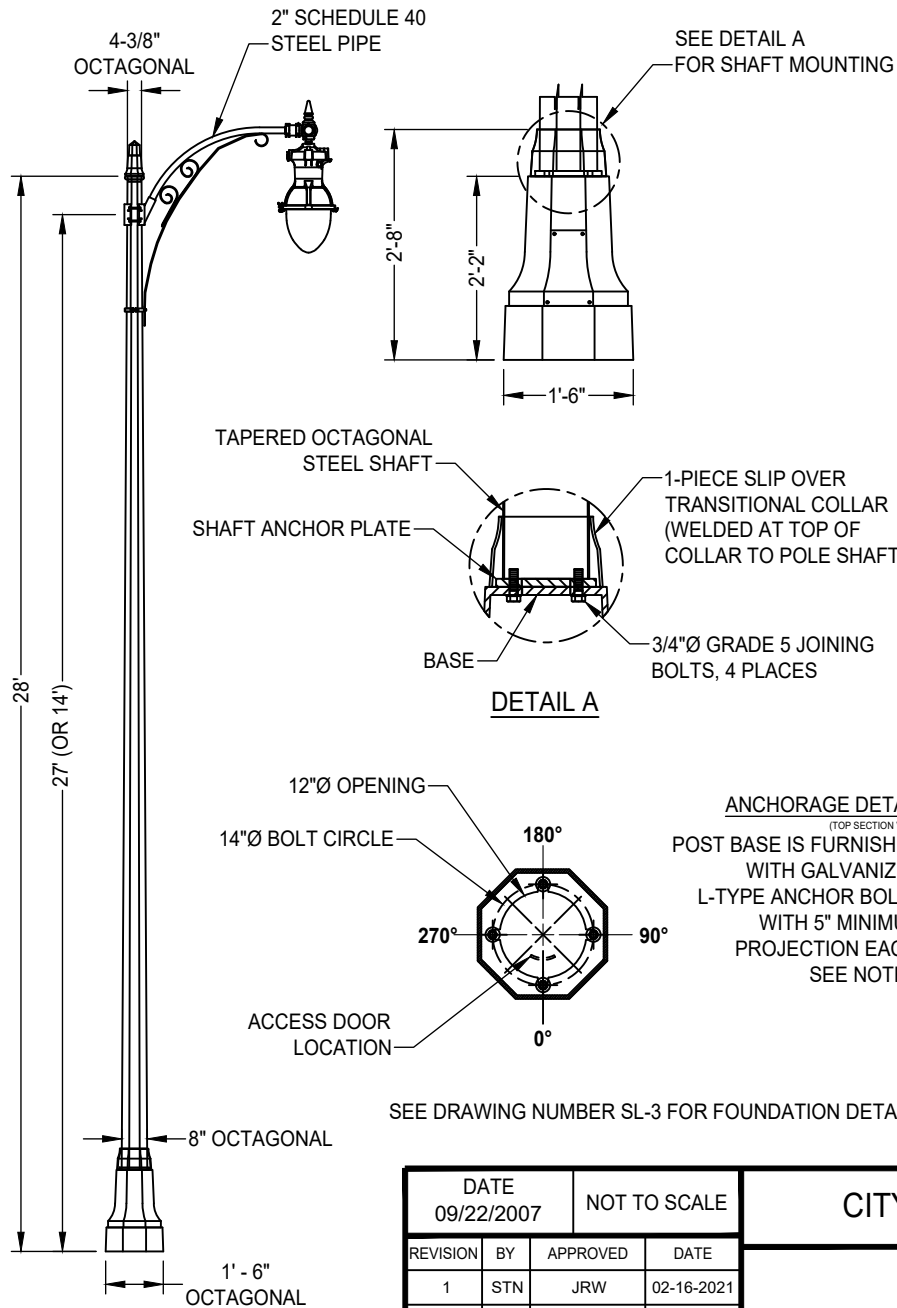

**APPLICATION:**

ARTERIAL (REDUCED MEDIAN) AND COLLECTOR STREETS

**SPECIFICATIONS:**

**POST BASE**

THE BASE SHALL BE CAST IRON CONSTRUCTION WITH A TAPERED AND STEPPED OCTAGONAL PATTERN. A 1-PIECE SLIP OVER TRANSITION COLLAR COVERS THE BASE OF THE SHAFT. A DOOR IS LOCATED IN THE BASE FOR ANCHORAGE AND WIRING ACCESS. A GROUND SCREW (5/8") SHALL BE PROVIDED INSIDE THE BASE, OPPOSITE THE ACCESS DOOR.

**POST SHAFT**

THE POST SHAFT SHALL BE 11-GAUGE STEEL WITH A STEEL PLATE FOR MOUNTING TO THE BASE. THE OCTAGONAL SHAFT TAPERS FROM 8" (FLAT TO FLAT) AT THE BOTTOM TO 4-3/8" AT THE TOP, WITH A DECORATIVE OCTAGONAL FINIAL.

**CROSSARM**

THE CLAMP ON CROSSARM SHALL BE STEEL PIPE CONSTRUCTION WITH FLAT BAR SCROLLS AND 1-1/2" X 1/2" FLAT BAR CLAMP-ON BRACE. A SLEEVE GASKET SHALL BE INSTALLED TO PREVENT ARM MOVEMENT. ARMS SHALL HAVE A 2" PIPE SLEEVE FOR LUMINAIRE MOUNTING. THE CROSSARM MEASURES 52" FROM POST TO LUMINAIRE CENTERS. A LUMINAIRE LEVELING FITTER SHALL BE MOUNTED TO THE END OF THE PIPE ARM FOR LUMINAIRE MOUNTING. FIXTURE MOUNT TO CROSSARM SHALL BE HOLOPHANE WEST LIBERTY STYLE, QSM, OR EQUIVALENT. THREADED FIXTURE MOUNTS SHALL NOT BE ALLOWED.

**FINISH**

THE POST SHALL BE SHIPPED FINISHED WITH A STANDARD BLACK POWDER COAT FINISH.

**NOTES:**

1. ALL HARDWARE STAINLESS STEEL. ALL EXTERIOR HARDWARE TAMPER RESISTANT. BASE AND SHAFT TO BE SHIPPED AS A ONE-PIECE UNIT.
2. POLES AND LIGHTING EQUIPMENT SHALL BE LISTED ON THE AUTHORIZED MATERIALS LIST.
3. ANCHOR BOLT SIZES SHALL BE PURSUANT TO THE POLE MANUFACTURUR'S DESIGN REQUIREMENTS. WHICH SHALL BE IN ACCORDANCE WITH AASHTO "STANDARD SPECIFICATIONS FOR STRUCTURAL SUPPORTS FOR HIGHWAY SIGNS, LUMINAIRES, AND TRAFFIC SIGNALS."

|                    |     |              |            |
|--------------------|-----|--------------|------------|
| DATE<br>09/22/2007 |     | NOT TO SCALE |            |
| REVISION           | BY  | APPROVED     | DATE       |
| 1                  | STN | JRW          | 02-16-2021 |
| 2                  | SJB | SMA          | 06-18-2025 |
|                    |     |              |            |
|                    |     |              |            |

CITY OF ELK GROVE - PUBLIC WORKS

APPROVED BY:

*[Signature]* 06-20-2025

CITY ENGINEER

DATE

**ZONE 2 ELECTROLIER  
(SERIES 'A')**



DRAWING NUMBER

**SL - 31**

# TEARDROP GLASS

ASYMMETRIC

**STANDARD**

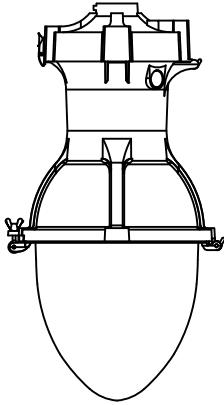

**SHALLOW SKIRT\***

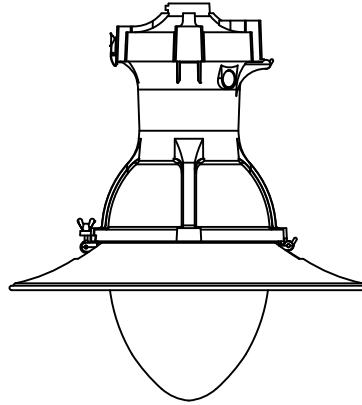

**DEEP SKIRT\***

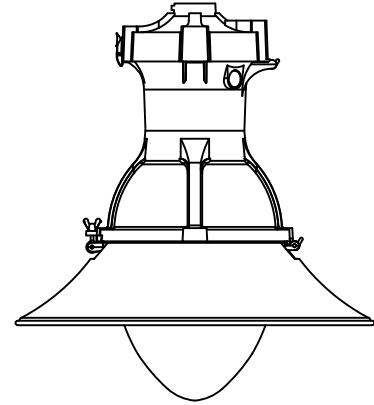

\*OPTIONAL UPON WRITTEN APPROVAL OF CITY ENGINEER

## SKIRT DIMENSIONS (OPTIONAL)

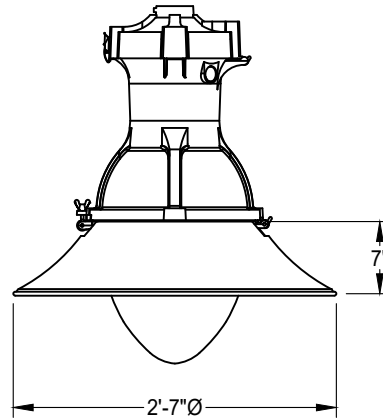
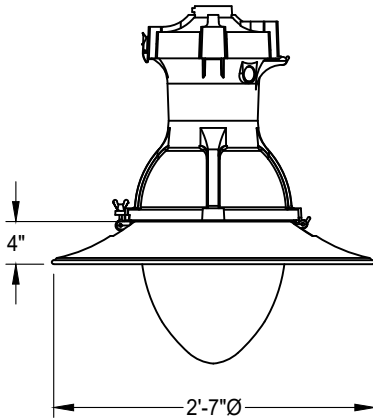

**NOTE:**

1. FIXTURE MOUNT TO CROSSARM SHALL BE HOLOPHONE WEST LIBERTY STYLE, QSM, OR EQUIVALENT. THREADED FIXTURE MOUNTS SHALL NOT BE ALLOWED.

|                     |     |              |            |
|---------------------|-----|--------------|------------|
| DATE:<br>09/22/2017 |     | NOT TO SCALE |            |
| REVISION            | BY  | APPROVED     | DATE       |
| 1                   | SJB | SMA          | 06-18-2025 |
|                     |     |              |            |
|                     |     |              |            |

CITY OF ELK GROVE - PUBLIC WORKS

---

**ZONE 2 LUMINAIRE OPTIONS  
(SERIES 'A')**

APPROVED BY: \_\_\_\_\_ 06-20-2025  
CITY ENGINEER DATE

---

DRAWING NUMBER  
**SL - 33**



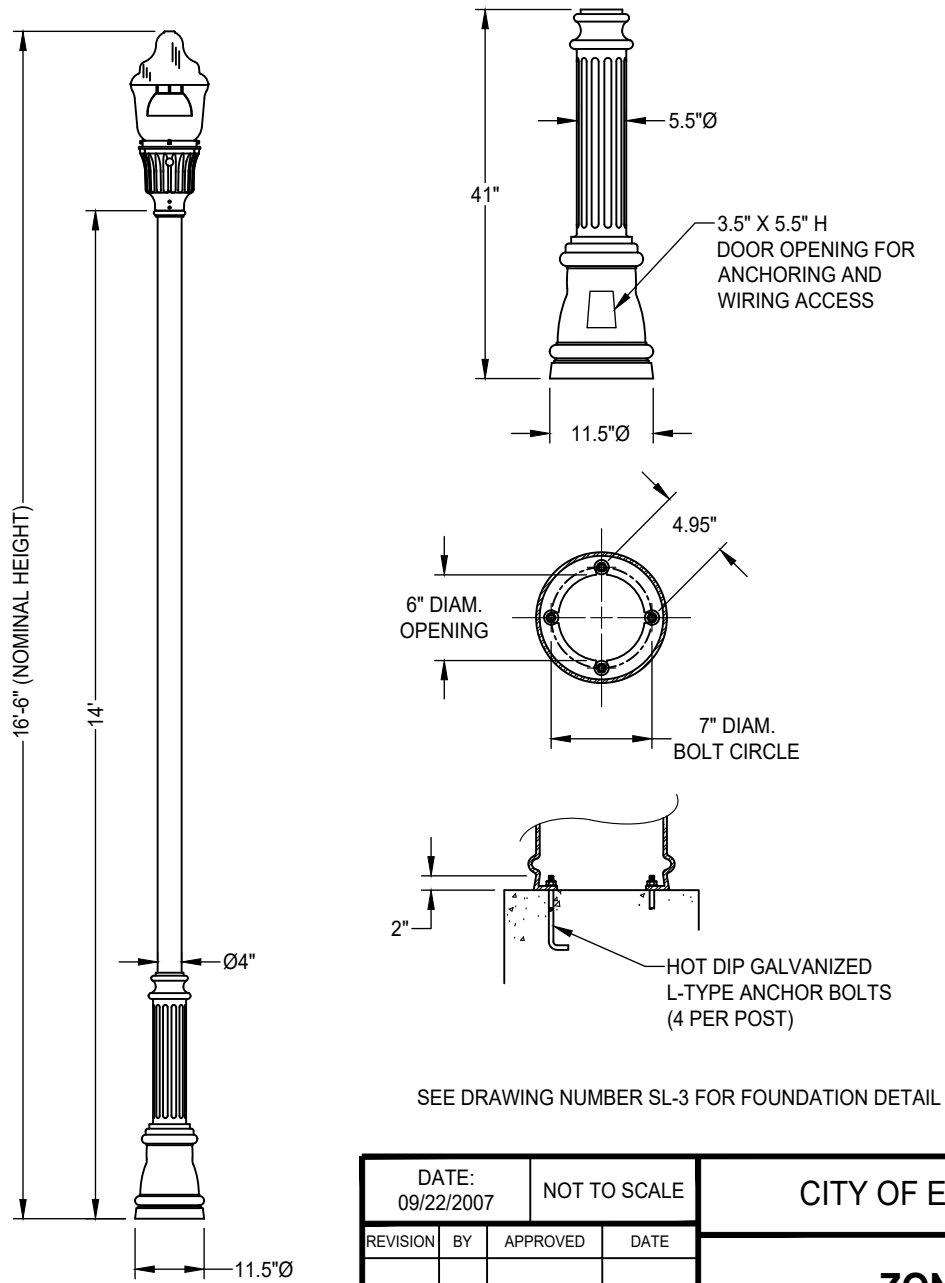

**APPLICATION:**

PEDESTRIAN TRAILS AND RESIDENTIAL STREETS

**SPECIFICATIONS:**

**POST DESCRIPTION**

THE LIGHTING POST SHALL BE ALL ALUMINUM, ONE-PIECE CONSTRUCTION, WITH A CLASSIC FLUTED BASE DESIGN. THE SHAFT SHALL BE Ø4" SMOOTH. THE POST SHALL BE SHIPPED WITH BLACK POWDER COAT FINISH.

**MATERIALS**

THE BASE SHALL BE HEAVY WALL, CAST ALUMINUM PRODUCED FROM CERTIFIED ASTM 356.1 INGOT PER ASTM B-179-95A OR ASTM B26-95. THE STRAIGHT SHAFTS SHALL BE EXTRUDED FROM ALUMINUM, ASTM 6061 ALLOY, HEAT TREATED TO A T6 TEMPER. ALL HARDWARE SHALL BE TAMPER RESISTANT STAINLESS STEEL. ANCHOR BOLTS TO BE COMPLETELY HOT DIP GALVANIZED.

**CONSTRUCTION**

THE SHAFT SHALL BE DOUBLE WELDED TO THE BASE CASTING AND SHIPPED AS ONE PIECE FOR MAXIMUM STRUCTURAL INTEGRITY. THE SHAFT SHALL BE CIRCUMFERENTIALLY WELDED INSIDE THE BASE CASTING AT THE TOP OF THE ACCESS DOOR, AND EXTERNALLY WHERE THE SHAFT EXITS THE BASE. ALL EXPOSED WELDS BELOW 8' SHALL BE GROUND SMOOTH. ALL WELDING SHALL BE PER ANSI/AWS D1.2-90. ALL WELDERS SHALL BE CERTIFIED PER SECTION 5 OF ANSI/AWS D1.2-90.

**DIMENSIONS**

THE POST SHALL BE 14' IN HEIGHT WITH AN 11-1/2" DIAMETER BASE. THE SHAFT DIAMETER SHALL BE 4". AT THE TOP OF THE POST, AN INTEGRAL 3" O.D. TENON WITH A TRANSITIONAL DONUT SHALL BE PROVIDED FOR LUMINAIRE MOUNTING.

**INSTALLATION**

THE POST SHALL BE PROVIDED WITH FOUR, HOT DIP GALVANIZED L-TYPE ANCHOR BOLTS TO BE INSTALLED ON AN 7" DIAMETER BOLT CIRCLE. A DOOR SHALL BE PROVIDED IN THE BASE FOR ANCHORAGE AND WIRING ACCESS. A GROUNDING SCREW (5/8") SHALL BE PROVIDED INSIDE THE BASE OPPOSITE THE DOOR.

**NOTES:**

1. POLES AND LIGHTING EQUIPMENT SHALL BE LISTED ON THE AUTHORIZED MATERIALS LIST.

|                     |    |              |      |
|---------------------|----|--------------|------|
| DATE:<br>09/22/2007 |    | NOT TO SCALE |      |
| REVISION            | BY | APPROVED     | DATE |
|                     |    |              |      |
|                     |    |              |      |
|                     |    |              |      |

CITY OF ELK GROVE - PUBLIC WORKS

APPROVED BY:

*Paul Murock*

10/24/2018

CITY ENGINEER

DATE

**ZONE 2 ELECTROLIER  
(SERIES 'B')**



DRAWING NUMBER

**SL-34**

| STREET CLASSIFICATION                              | NUMBER OF LANE | STREET LIGHT SUB-TYPE (SERIES) | STANDARD POLE HEIGHT | MEDIAN                       | NO MEDIAN (SERIES 'A') (BOTH SIDES) |
|--|----------------|--------------------------------|----------------------|------------------------------|-------------------------------------|
|  |                |                                |                      | MAXIMUM SPACING ("D") (FEET) |                                     |
| SPECIAL THOROUGHFARE                               | 8              | DUAL ARM                       | 28'                  | 160                          | 160                                 |
| THOROUGHFARE                                       | 6              | DUAL ARM                       | 28'                  | 160                          | 160                                 |
| ARTERIAL   | 2 - 4          | DUAL ARM                       | 28'                  | 180                          | 180                                 |
| SPACING (BOTH SIDES) (FEET)                        |                |                                |                      |                              |                                     |
| COLLECTOR  | 2, 3           | SERIES 'A**                    | 28'                  | 180                          |                                     |
|  | 2, 3           | SERIES 'B**                    | 14'                  | 150                          |                                     |
|  | 2              | SERIES 'A***                   | 28'                  | 80                           |                                     |
|  | 2              | SERIES 'B***                   | 14'                  | 80                           |                                     |
| LOCAL RESIDENTIAL                                  | 2              | SERIES 'B'                     | 14'                  | 180                          |                                     |
|  | 2              | SERIES 'A'                     | 28'                  | 180                          |                                     |
| PASEO, BIKE TRAILS, AND SEPARATED PEDESTRIAN PATHS | -              | SERIES 'B'                     | 14'                  | 120                          |                                     |
| PEDESTRIAN PATHS ON 4 - 8 LANE STREETS             | -              | SERIES 'B'                     | 14'                  | 160 - 180***                 |                                     |

**NOTES:**

1. WATTAGE AND MODEL NUMBER FOR LIGHT EMITTING DIODE (LED) LAMP SHALL BE SPECIFIED ON THE PLANS. EQUIPMENT SHALL CONFORM TO CITY OF ELK GROVE APPROVED EQUIPMENT LIST.

2. ILLUMINATION SHALL CONFORM TO STANDARD DRAWING SL-2.

\* BOTH SIDES OF STREET, NO ALTERNATING (2 PER LOCATION). NOT FOR USE ON STREETS LONGER THAN 800 FEET.

\*\* SINGLE SIDE OF STREET, ALTERNATING SPACING.

\*\*\* MATCH STREET SPACING. LOCATE HALFWAY BETWEEN STREET LIGHT LOCATIONS.

|                     |    |              |      |
|---------------------|----|--------------|------|
| DATE:<br>09/22/2007 |    | NOT TO SCALE |      |
| REVISION            | BY | APPROVED     | DATE |
|                     |    |              |      |
|                     |    |              |      |
|                     |    |              |      |

CITY OF ELK GROVE - PUBLIC WORKS

---

**ZONE 2 POLE SPACING GUIDE  
(SERIES 'A'/SERIES 'B'/DUAL ARM)**

APPROVED BY:  
*Paul Murock* 10/24/2018  
CITY ENGINEER DATE

---

DRAWING NUMBER  
**SL - 36**



# STREET LIGHT PLACEMENT ON SPECIAL THOROUGHFARE, THOROUGHFARE, & ARTERIAL STREETS (INCLUDES COLLECTORS WITH MEDIAN)

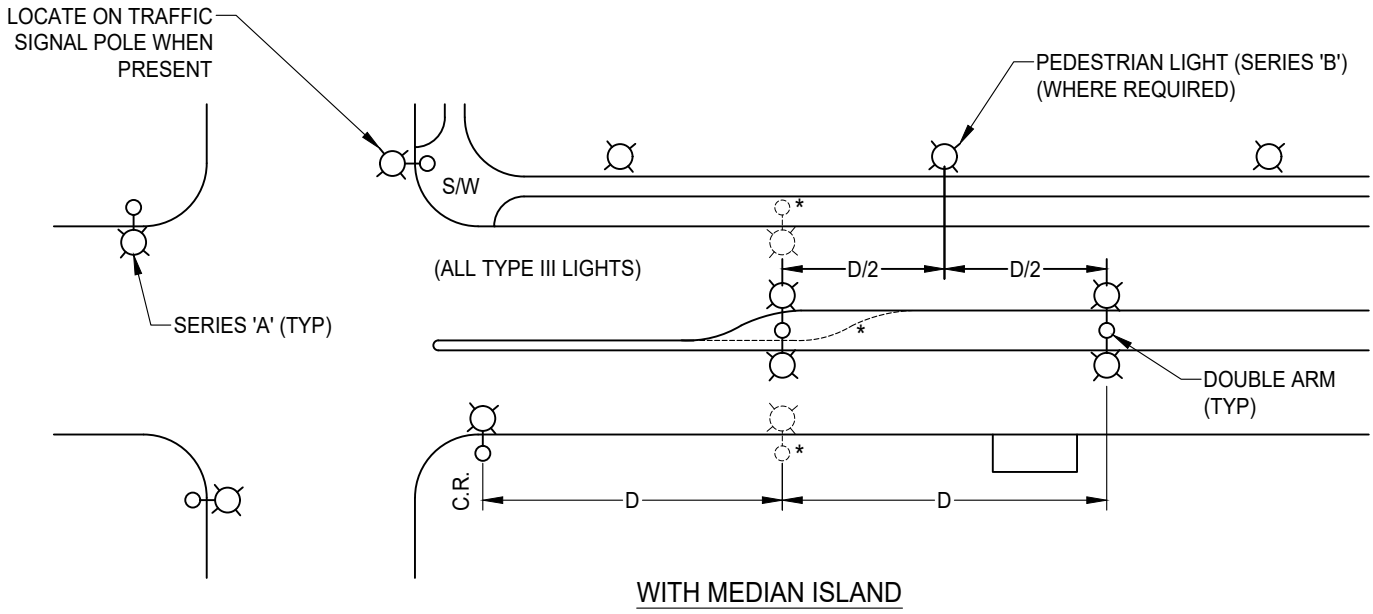

\*SEE STANDARD DRAWING SL-36 FOR DISTANCE "D"

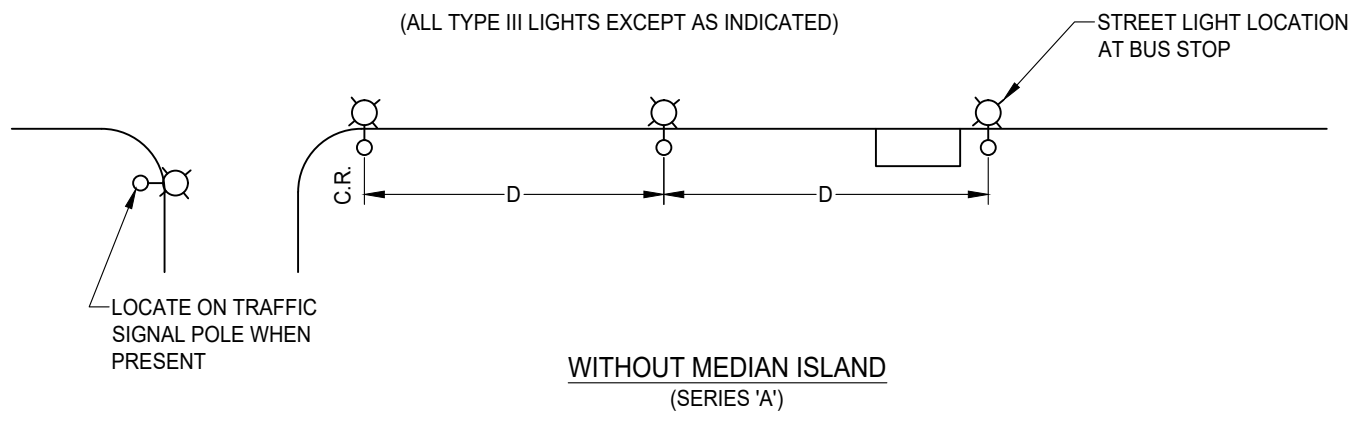
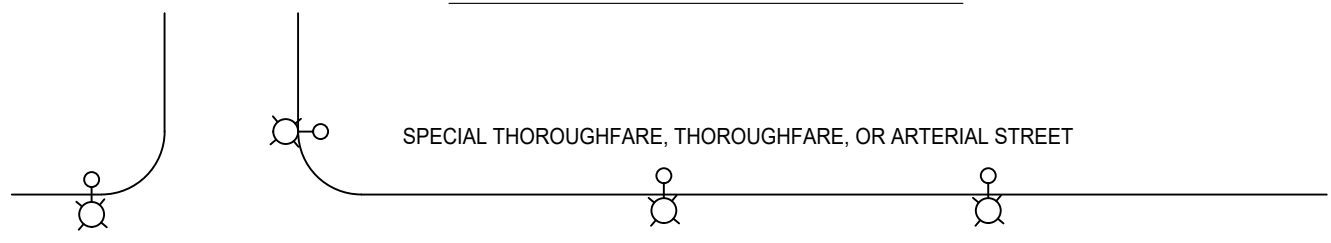

|                     |    |              |      |
|---------------------|----|--------------|------|
| DATE:<br>09/22/2017 |    | NOT TO SCALE |      |
| REVISION            | BY | APPROVED     | DATE |
|                     |    |              |      |
|                     |    |              |      |
|                     |    |              |      |

CITY OF ELK GROVE - PUBLIC WORKS

**ZONE 2 TYPICAL LOCATIONS ARTERIALS  
AND COLLECTORS WITH MEDIANS  
(SERIES 'A' / SERIES 'B' / DUAL ARM)**

APPROVED BY:  
*Paul Murod* 10/24/2018  
CITY ENGINEER DATE

DRAWING NUMBER  
**SL - 37**



# STREET LIGHT PLACEMENT ON MAJOR COLLECTOR, COLLECTOR (NO MEDIAN), & RESIDENTIAL STREETS

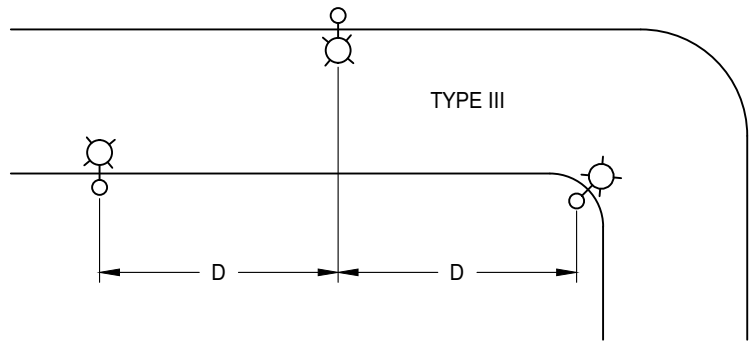
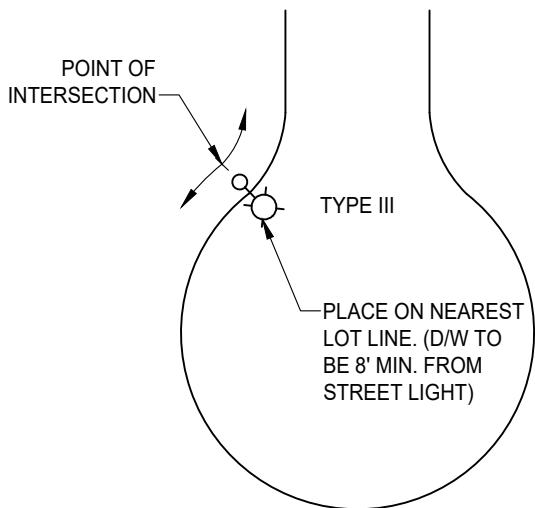
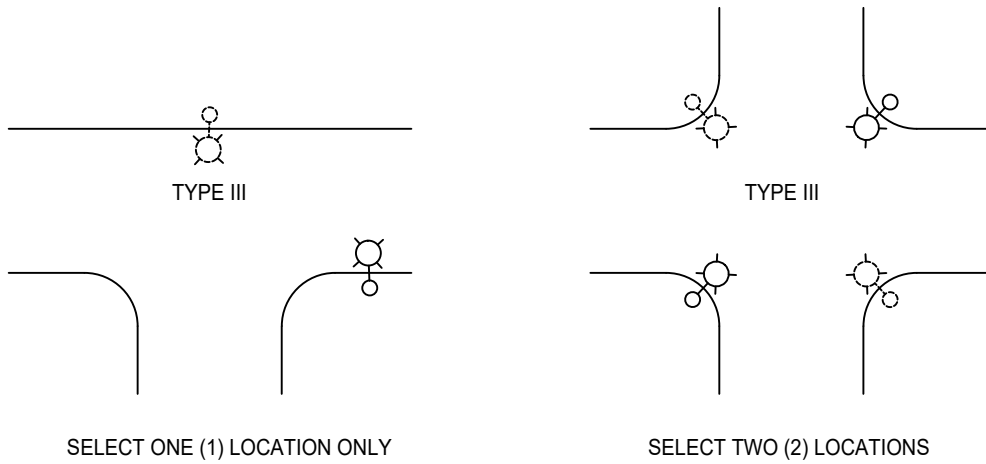

\*SEE STANDARD DRAWING SL-36 FOR DISTANCE "D"

|                     |    |              |      |
|---------------------|----|--------------|------|
| DATE:<br>09/22/2017 |    | NOT TO SCALE |      |
| REVISION            | BY | APPROVED     | DATE |
|                     |    |              |      |
|                     |    |              |      |
|                     |    |              |      |

CITY OF ELK GROVE - PUBLIC WORKS

**ZONE 2 TYPICAL LOCATIONS**  
**COLLECTOR AND RESIDENTIAL STREETS**  
**(SERIES 'A' / SERIES 'B')**

APPROVED BY:  
*Paul Murock*      10/24/2018  
CITY ENGINEER      DATE

DRAWING NUMBER  
**SL - 38**



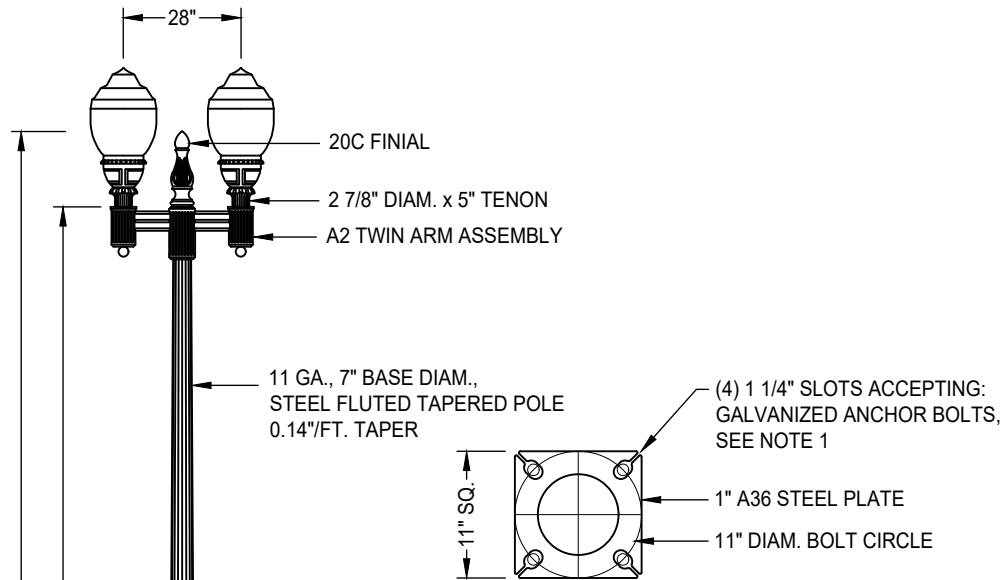

**BASE PLATE DETAIL**

**NOTES:**

- ANCHOR BOLT SIZES SHALL BE PURSUANT TO THE POLE MANUFACTURER'S DESIGN REQUIREMENTS, WHICH SHALL BE IN ACCORDANCE WITH AASHTO "STANDARD SPECIFICATIONS FOR STRUCTURAL SUPPORTS FOR HIGHWAY SIGNS, LUMINAIRES, AND TRAFFIC SIGNALS."

- APPLY SILICONE SEALANT AT INSTALLATION
- 12A/7 BASE COLLAR
- 11A/7 UPPER BASE SECTION WITH REMOVABLE ACCESS DOOR

10A LOWER BASE SECTION

**APPLICATION:**

THOROUGHFARE AND ARTERIAL STREETS

**SPECIFICATIONS:**

**POST DESCRIPTION**

THE LAGUNA WEST LIGHTING POST SHALL BE ALL STEEL OR CAST IRON CONSTRUCTION WITH A FLUTED BASE DESIGN. THE STEEL SHAFT SHALL BE FLUTED AND TAPERED WITH A 7" BASE DIAMETER. THE POST SHALL BE SHIPPED WITH FINISH NOTED BELOW.

**MATERIALS**

THE BASE SHALL BE CAST IRON AND SHAFT SHALL BE STEEL. THE BASE AND SHAFT SHALL BE PRIME PAINTED INSIDE AND OUT WITH A ZINC-RICH RUST INHIBITING, EPOXY BASED PAINT.

POLES INSTALLED ON OR NEAR LAGUNA BLVD (NORTH OF THE ELIOT RANCH ROAD ALIGNMENT) SHALL BE PAINTED OUTSIDE WITH URETHANE GLOSS ENAMEL OF FEDERAL COLOR STANDARD 595B, COLOR #14516 "AQUA MARINE". POLES INSTALLED ON OR NEAR ELK GROVE BLVD (SOUTH OF THE ELIOT RANCH ROAD ALIGNMENT) SHALL BE PAINTED OUTSIDE WITH URETHANE GLOSS ENAMEL OF FEDERAL COLOR STANDARD 595B, COLOR #17083 "GLOSS BLACK". ONE PINT OF TOUCH-UP PAINT SHALL BE SHIPPED WITH EACH POLE ORDER.

ALL POLES SHALL BE FINISHED WITH A CLEAR COAT OF URETHANE GLOSS FINISH. ANCHOR BOLTS AND NUTS SHALL BE HOT DIPPED GALVANIZED STEEL.

**CONSTRUCTION**

THE POLE SHAFT SHALL BE WELDED TO THE ANCHOR PLATE AND PAINTED AFTER WELDING. WELDS SHALL CONFORM TO THE MOST RECENT EDITION OF AWS D1.1. THE BASE SHALL BE FABRICATED OF ONE OR TWO PIECES AND INSTALLED AFTER THE POLE SHAFT IS BOLTED TO THE FOUNDATION. THE FINISH OF THE POLE SHAFT SHALL BE PROTECTED FROM DAMAGE WHEN THE BASE IS INSTALLED. POLE AND BASE SHALL BE SHIPPED AS TWO PIECES.

**DIMENSIONS**

THE POST SHALL BE 19' 6" IN HEIGHT WITH A 20" DIAMETER BASE. THE SHAFT SHALL BE TAPERED 0.14" PER FOOT WITH A 7" BASE DIAMETER. AT THE TOP OF THE POST, TWO INTEGRAL 2 7/8" X5" TENONS SHALL BE PROVIDED FOR LUMINAIRE MOUNTING.

**INSTALLATION**

THE POST SHALL BE PROVIDED WITH FOUR, HOT DIP GALVANIZED L-TYPE ANCHOR BOLTS TO BE INSTALLED AS SHOWN IN THE BASE PLATE DETAIL. AN ACCESS DOOR SHALL BE PROVIDED IN THE BASE FOR ANCHORAGE AND WIRING ACCESS. A GROUNDING SCREW (5/8") SHALL BE PROVIDED INSIDE THE BASE OPPOSITE THE DOOR.

**PRODUCT**

VISCO V1-A7-A2-F/19' 6", ELK GROVE

|                    |     |              |            |
|--------------------|-----|--------------|------------|
| DATE<br>09/22/2007 |     | NOT TO SCALE |            |
| REVISION           | BY  | APPROVED     | DATE       |
| 01                 | STN | JRW          | 02/16/2021 |
|                    |     |              |            |
|                    |     |              |            |

CITY OF ELK GROVE - PUBLIC WORKS

**LAGUNA WEST ELECTROLIER  
(DUAL ARM)**

APPROVED BY:

*Robert M. Muddoch*

02/26/2021

CITY ENGINEER

DATE



DRAWING NUMBER

**SL - 40**

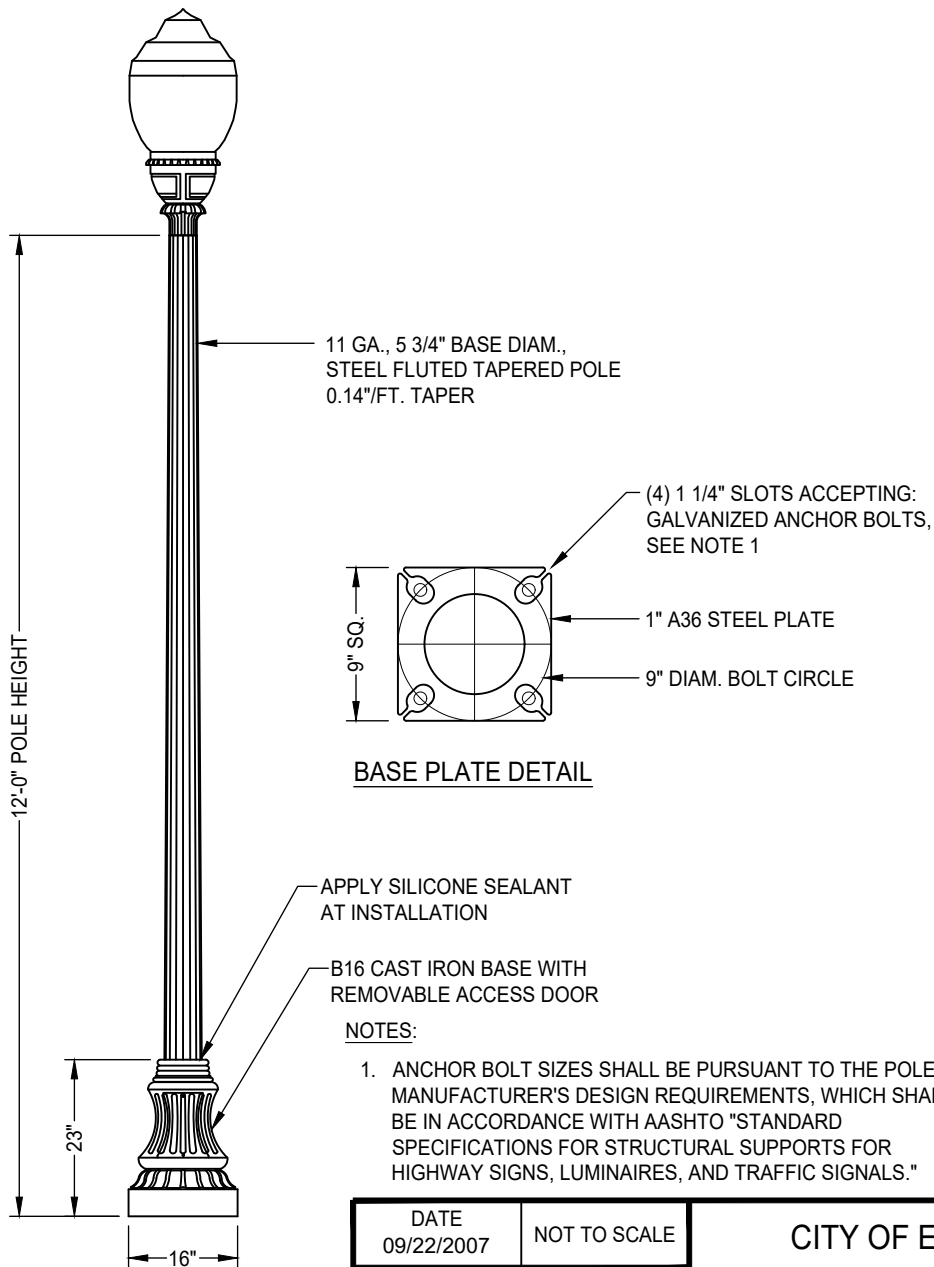

11 GA., 5 3/4" BASE DIAM.,  
STEEL FLUTED TAPERED POLE  
0.14"/FT. TAPER

(4) 1 1/4" SLOTS ACCEPTING:  
GALVANIZED ANCHOR BOLTS,  
SEE NOTE 1

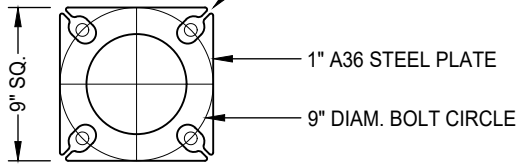

BASE PLATE DETAIL

APPLY SILICONE SEALANT  
AT INSTALLATION

B16 CAST IRON BASE WITH  
REMOVABLE ACCESS DOOR

NOTES:

1. ANCHOR BOLT SIZES SHALL BE PURSUANT TO THE POLE MANUFACTURER'S DESIGN REQUIREMENTS, WHICH SHALL BE IN ACCORDANCE WITH AASHTO "STANDARD SPECIFICATIONS FOR STRUCTURAL SUPPORTS FOR HIGHWAY SIGNS, LUMINAIRES, AND TRAFFIC SIGNALS."

APPLICATION:

RESIDENTIAL STREETS AND PEDESTRIAN TRAILS

SPECIFICATIONS:

**POST DESCRIPTION**

THE LAGUNA WEST LIGHTING POST SHALL BE ALL STEEL OR CAST IRON CONSTRUCTION WITH A FLUTED BASE DESIGN. THE SHAFT SHALL BE FLUTED AND TAPERED WITH A 5 3/4" BASE DIAMETER. THE POST SHALL BE SHIPPED WITH FINISH NOTED BELOW.

**MATERIALS**

THE BASE SHALL BE CAST IRON AND SHAFT SHALL BE STEEL. THE BASE AND SHAFT SHALL BE PRIME PAINTED INSIDE AND OUT WITH RUST INHIBITING, EPOXY BASED PAINT.

POLES INSTALLED ON OR NEAR LAGUNA BLVD (NORTH OF THE ELLIOT RANCH ROAD ALIGNMENT) SHALL BE PAINTED OUTSIDE WITH URETHANE GLOSS ENAMEL OF FEDERAL COLOR STANDARD 595B, COLOR #14516 "AQUA MARINE". POLES INSTALLED ON OR NEAR ELK GROVE BLVD (SOUTH OF THE ELLIOT RANCH ROAD ALIGNMENT) SHALL BE PAINTED OUTSIDE WITH URETHANE GLOSS ENAMEL OF FEDERAL COLOR STANDARD 595B, COLOR #17083 "GLOSS BLACK". ONE PINT OF TOUCH-UP PAINT SHALL BE SHIPPED WITH EACH POLE ORDER.

ALL POLES SHALL BE FINISHED WITH A CLEAR COAT OF URETHANE GLOSS FINISH. ANCHOR BOLTS AND NUTS SHALL BE HOT DIPPED GALVANIZED STEEL.

**CONSTRUCTION**

THE POLE SHAFT SHALL BE WELDED TO THE ANCHOR PLATE AND PAINTED AFTER WELDING. WELDS SHALL CONFORM TO THE MOST RECENT EDITION OF AWS D1.1. THE BASE SHALL BE FABRICATED OF ONE OR TWO PIECES AND INSTALLED AFTER THE POLE SHAFT IS BOLTED TO THE FOUNDATION. THE FINISH OF THE POLE SHAFT SHALL BE PROTECTED FROM DAMAGE WHEN THE BASE IS INSTALLED. POLE AND BASE SHALL BE SHIPPED AS TWO PIECES.

**DIMENSIONS**

THE POST SHALL BE 12' 0" IN HEIGHT WITH A 16" DIAMETER BASE. THE SHAFT SHALL BE TAPERED 0.14" PER FOOT WITH A 5 3/4" BASE DIAMETER. AT THE TOP OF THE POST, AN INTEGRAL 2 7/8" X3" TENON SHALL BE PROVIDED FOR LUMINAIRE MOUNTING.

**INSTALLATION**

THE POST SHALL BE PROVIDED WITH FOUR, HOT DIP GALVANIZED L-TYPE ANCHOR BOLTS TO BE INSTALLED AS SHOWN IN THE BASE PLATE DETAIL. AN ACCESS DOOR SHALL BE PROVIDED IN THE BASE FOR ANCHORAGE AND WIRING ACCESS. A GROUNDING SCREW (5/8") SHALL BE PROVIDED INSIDE THE BASE OPPOSITE THE DOOR.

**PRODUCT**

VISCO V1-B16-1-F/12', ELK GROVE

|                    |     |              |            |
|--------------------|-----|--------------|------------|
| DATE<br>09/22/2007 |     | NOT TO SCALE |            |
| REVISION           | BY  | APPROVED     | DATE       |
| 01                 | STN | JRW          | 02/16/2021 |
|                    |     |              |            |
|                    |     |              |            |

CITY OF ELK GROVE - PUBLIC WORKS

**LAGUNA WEST ELECTROLIER  
(SERIES 'B')**

APPROVED BY:

*Paul M. ...* 02/26/2021  
CITY ENGINEER DATE



DRAWING NUMBER

**SL - 42**

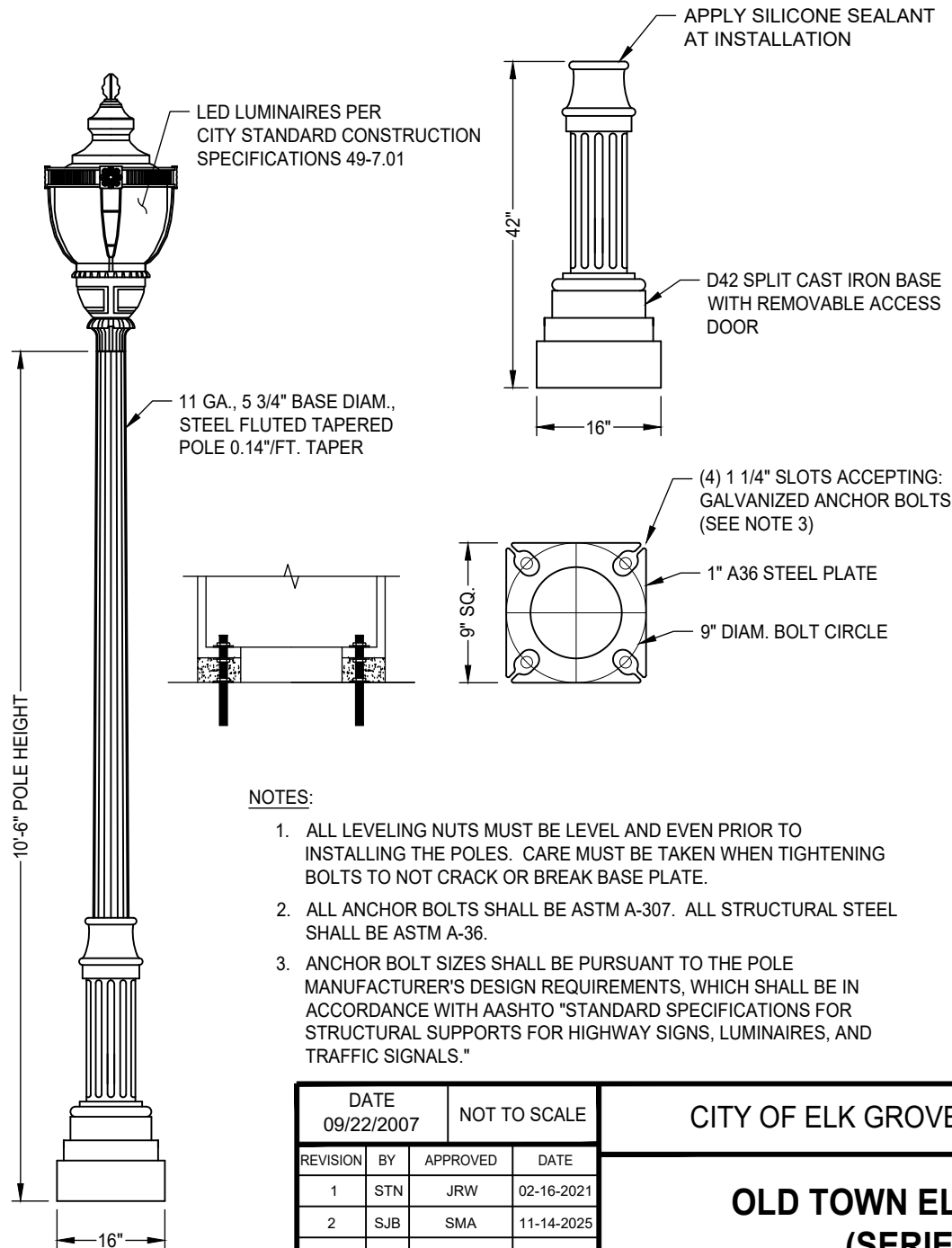

**NOTES:**

1. ALL LEVELING NUTS MUST BE LEVEL AND EVEN PRIOR TO INSTALLING THE POLES. CARE MUST BE TAKEN WHEN TIGHTENING BOLTS TO NOT CRACK OR BREAK BASE PLATE.
2. ALL ANCHOR BOLTS SHALL BE ASTM A-307. ALL STRUCTURAL STEEL SHALL BE ASTM A-36.
3. ANCHOR BOLT SIZES SHALL BE PURSUANT TO THE POLE MANUFACTURER'S DESIGN REQUIREMENTS, WHICH SHALL BE IN ACCORDANCE WITH AASHTO "STANDARD SPECIFICATIONS FOR STRUCTURAL SUPPORTS FOR HIGHWAY SIGNS, LUMINAIRES, AND TRAFFIC SIGNALS."

**APPLICATION:**

BUSINESS DISTRICT OLD TOWN

**SPECIFICATIONS:**

**POST DESCRIPTION**

THE OLD TOWN LIGHTING POST SHALL BE ALL STEEL CONSTRUCTION WITH A FLUTED BASE DESIGN. THE SHAFT SHALL BE FLUTED AND TAPERED WITH A 5/8" BASE DIAMETER. THE POST SHALL BE SHIPPED WITH FINISH NOTED BELOW.

**MATERIALS**

THE BASE AND POLE SHALL BE CAST STEEL. THE BASE AND POLE SHALL BE PRIME PAINTED INSIDE AND OUT WITH RUST INHIBITING, EPOXY BASED PAINT, PAINTED OUTSIDE WITH URETHANE GLOSS ENAMEL OF FEDERAL COLOR STANDARD 595B, COLOR #17083 "GLOSS BLACK", AND FINISHED WITH A CLEAR COAT OF URETHANE GLOSS FINISH. ANCHOR BOLTS AND NUTS SHALL BE HOT DIPPED GALVANIZED STEEL.

**CONSTRUCTION**

THE SHAFT AND BASE SHALL BE CAST IN ONE PIECE OR SHALL BE DOUBLE WELDED (TOP AND BOTTOM OF BASE). WELDS SHALL BE GROUND SMOOTH. WELDS SHALL CONFORM TO AWS D1.1. POLE AND BASE SHALL BE SHIPPED AS ONE PIECE.

**DIMENSIONS**

THE POST SHALL BE 10' 6" IN HEIGHT WITH AN 11.5" DIAMETER BASE. THE SHAFT SHALL BE TAPERED WITH A 5/8" BASE DIAMETER. AT THE TOP OF THE POST, AN INTEGRAL 2 7/8" X3" TENON SHALL BE PROVIDED FOR LUMINAIRE MOUNTING.

**INSTALLATION**

THE POST SHALL BE PROVIDED WITH FOUR, HOT DIP GALVANIZED L-TYPE ANCHOR BOLTS TO BE INSTALLED AS SHOWN IN THE BASE DETAIL. AN ACCESS DOOR SHALL BE PROVIDED IN THE BASE FOR ANCHORAGE AND WIRING ACCESS. A GROUNDING SCREW (5/8") SHALL BE PROVIDED INSIDE THE BASE OPPOSITE THE DOOR.

**PRODUCT**

VISCO V1-D42-F, ELK GROVE 3A

|                    |     |              |            |
|--------------------|-----|--------------|------------|
| DATE<br>09/22/2007 |     | NOT TO SCALE |            |
| REVISION           | BY  | APPROVED     | DATE       |
| 1                  | STN | JRW          | 02-16-2021 |
| 2                  | SJB | SMA          | 11-14-2025 |
|                    |     |              |            |
|                    |     |              |            |

CITY OF ELK GROVE - PUBLIC WORKS

**OLD TOWN ELECTROLIER  
(SERIES 'B')**

APPROVED BY:  11-14-2025

CITY ENGINEER DATE

DRAWING NUMBER

SL - 46

