



Standard Drawings

2026



City of
Elk Grove
PROUD HERITAGE. BRIGHT FUTURE.

Amended by City Engineer on
January 15, 2026



Table of Contents

ACCESSIBLE RAMPS

AR-2.0	Curb Ramp Elements Definitions and Stand
AR-3.0	Curb Ramp General Details
AR-3.1	Detectable Warning Specifications
AR-3.2A	Detectable Warning Standard Layout
AR-3.2B	Detectable Warning Standard Layout
AR-4.1	Dual Parallel Curb Ramps
AR-4.2	Single Parallel Curb Ramp For Uncontrolled T-Intersections
AR-4.3	Dual Perpendicular Curb Ramps with Attached Sidewalk
AR-4.4	Single Perpendicular Ramp
AR-4.5	Dual Flared Perpendicular Curb Ramps with Detached Sidewalk
AR-4.6	Dual Perpendicular Curb Ramps with Detached Sidewalk
AR-4.7	Sidewalk Driveway Detail
AR-4.8	Detached Sidewalk Driveway Details

DRAFTING

D-1	Approval Blocks
D-2	Drafting Standards
D-3	Standard Map Associated with Legal Description for 8-1/2" x 11" Sheet

GRADING

G-1	Exterior Perimeter Property Line Grading for Fill Areas
G-2	Grading for Interior Property Lines and Perimeter Property Lines in Cut Areas
G-3	Wood Retaining Wall Details for Interior Property Lines
G-4	Masonry/Concrete Retaining Way Detail for Fill Areas at Boundary and Project Phase Lines

LANDSCAPING

L-1	Tree Planting
L-2	Shrub Planting
L-3	Remote Control Valve
L-4	Drip Irrigation Valve Assembly
L-5	Quick Coupling Valve
L-6	Master Valve Flow Sensor

L-7	Flush Valve
L-8	Air Relief Valve
L-9	Pop-Up Rotor Sprinkler
L-10	Pop-Up Spray Sprinkler
L-11	Bubbler Sprinkler Head
L-12	Drip Irrigation Multi-Outlet Emitter
L-13	Subsurface In-Line Drip Irrigation Layout
L-14	Subsurface In-Line Drip Irrigation Center-Feed Supply Manifold
L-15	Subsurface In-Line Drip Irrigation End-Feed Supply Manifold
L-16	Deep Watering Pipe for Trees
L-17	Irrigation Controller Enclosure
L-18	Irrigation System Trenching
L-19	Drinking Fountain
L-20	Post and Cable Fencing
L-21	Stationary Bollard
L-23	Concrete Walk (In park Areas, not Frontage Areas)
L-24	Concrete Mow Strip
L-25	Bike Trail Paving Section
L-26	Roadway Median Section
L-27	Redwood Headerboard
L-28	Double Pipe Gate
L-29	Single Pipe Gate

STORM DRAINAGE

SD-1	10-Year Peak Flow Sacramento Method Rainfall Zone 2, <80 Acres
SD-1A	Design Runoff Nolte Method Drainage Areas, <50 Acres
SD-1B	Design Runoff Nolte Method Residential Areas, 50-160 Acres
SD-1C	Design Runoff Nolte Method Commercial Areas, 50-160 Acres
SD-2	10-Year Peak Flow Sacramento Method Rainfall Zone 2, 80-640 Acres
SD-3	100-Year Peak Flow Sacramento Method Rainfall Zone 2, <80 Acres
SD-4	100-Year Peak Flow Sacramento Method Rainfall Zone 2, 80-640 Acres
SD-5	Loss in Junction Due to Change in Direction of Flow in Lateral
SD-6.0	Storm Drain Trench Detail
SD-6.1	Storm Drain Reinforced Concrete Pipe Bedding and Initial Backfill
SD-6.2	Storm Drain Plastic Pipe Bedding and Initial Backfill
SD-6.3	Cutoff Collar
SD-7.0	Standard Precast Concrete Drainage Manhole
SD-7.1	Cast-in-Place Concrete Drainage Manhole
SD-7.2	Cast-in-Place Concrete Drainage Manhole
SD-8A	Type A Saddle Manhole

SD-8B	Type B Saddle Manhole
SD-9	Grey Cast Iron Standard 24" Manhole Frame & Cover
SD-10	Grey Cast Iron Standard 36" Manhole Frame & Cover
SD-11	Grate Type Manhole Cover
SD-12	Drop Inlet Type B
SD-12.1	Drop Inlet Type B at Detached Sidewalk
SD-13	Drop Inlet Type C
SD-14	Welded Steel Grate Frame
SD-15	Welded Steel Grate
SD-16	Center Support Assembly for Multiple Grates
SD-17	Catch Basin Face Plate Assembly and Protection Bar
SD-18	Drop Inlet Type F
SD-19.1	Drop Inlet Type G, Type 2 C&G Only (Page 1 of 2)
SD-19.2	Drop Inlet Type G, Type 2 C&G Only (Sheet 2 of 2)
SD-19.3	Modified Type J Inlet
SD-19.4	Precast Drop Inlet Type J
SD-23	Pipe Connects
SD-24	Flexible Pipe to Manhole Connection
SD-25	Typical Ramp and Transition Detail
SD-26	Outlet Pipe Headwall and Apron
SD-27	Ditch Discharge Control and Apron
SD-28.1	Trash Rack 24"-36" Pipe (Sheet 1 of 4)
SD-28.2	Trash Rack 42" Pipe and Larger (Sheet 2 of 4)
SD-28.3	Trash Rack 42" Pipe and Larger (Sheet 3 of 4)
SD-28.4	Trash Rack Details (Sheet 4 of 4)
SD-29.1	Inlet Pipe Headwall Wingwall Structure (Sheet 1 of 2)
SD-29.2	Inlet Pipe Headwall Wingwall Structure (Sheet 2 of 2)
SD-30.1	Lined Channel Section (Sheet 1 of 2)
SD-30.2	Lined Channel Section (Sheet 2 of 2)
SD-31	Utility Stream Crossing

STREET LIGHTING

SL-1	Street Lighting Poles and Symbols
SL-2	Street Lighting Illumination Criteria
SL-3	Street Light Foundations
SL-4	Standard Pull Box
SL-5	Traffic-Rated Pull Box
SL-6	Base Location for Street Light
SL-7	Underground Service Installation
SL-8	Metered Service Pedestal (Can) (120/208V, 120/240V)

SL-9	Metered Service Pedestal (Can) with Step-Down Transformer (277/480V to 120/240V)
SL-12	In-Line Fuse Requirements
SL-13	2-Wire Street Light System Wire Size and Voltage Drop Calculation
SL-14	3-Wire Street Light System Wire Size and Voltage Drop Calculation
SL-15	Conduit, Service Wire and Breaker Sizing
SL-19	Street Light Areas
SL-20	Common Type Electrolier (Series 'A')
SL-22	Common Type Electrolier (Series 'B')
SL-24	Common Type Street Light Pole Spacing Guide (Series 'A'/Series 'B')
SL-25	Common Type Typical Locations Arterial Streets (Series 'A'/Series 'B')
SL-26	Common Type Typical Locations Collector and Residential Streets (Series 'A'/Series 'B')
SL-30	Zone 2 Electrolier (Dual Arm)
SL-31	Zone 2 Electrolier (Series 'A')
SL-33	Zone 2 Luminaire Options (Series 'A')
SL-34	Zone 2 Electrolier (Series 'B')
SL-36	Zone 2 Pole Spacing Guide (Series 'A'/Series 'B'/Dual Arm)
SL-37	Zone 2 Typical Locations Arterials and Collectors with Medians (Series 'A'/Series 'B'/Dual Arm)
SL-38	Zone 2 Typical Locations Collector and Residential Street (Series 'A'/Series 'B')
SL-40	Laguna West Electrolier (Dual Arm)
SL-42	Laguna West Electrolier (Series 'B')
SL-46	Old Town Electrolier (Series 'B')

STORMWATER QUALITY

SQ-1	Stabilized Construction Site Access
SQ-3	Sediment Trap Stabilized Outlet SQ-3
SQ-4	Fiber Rolls
SQ-5	Silt Fence
SQ-6	Concrete Washout
SQ-7	Inlet Sediment Control
SQ-8	Storm Drain Inlet Filter Bag
SQ-9A	Erosion Control Blankets/Mats Channel Installation
SQ-9B	Erosion Control Blankets/Mats Slope Installation
SQ-10.1	Drop Inlet Concrete Stamp (Sheet 1 of 2)
SQ-10.2	Drop Inlet Concrete Stamp (Sheet 2 of 2)

STREETS

ST-1A	Trench Backfilling and Resurfacing
ST-5	Trench Resurfacing When Fabric is Required
ST-6A	Utility Pothole Repair
ST-7	General Notes
ST-8	Typical Trench Compaction Detail
ST-8A	Manhole Backfill Detail
ST-9	Temporary Trench Resurfacing
ST-10	Trench Sections in Improved Area Horticulture, Lawn or Cultivated Areas
ST-11	Widening Details for Thoroughfares at Various Street Intersections
ST-12A	Widening Details for Arterials at Major Street Intersections
ST-12B	Widening Details for Arterials at Collector Street Intersections
ST-13	Typical Striping for Collector Streets with Bicycle Lanes at Intersections with Thoroughfare or Arterial Streets
ST-14A	Typical Striping for Arterial Intersections with Thoroughfares or Arterials
ST-14B	Typical Striping for Arterial Intersections with Collectors
ST-15A	Typical Striping for Thoroughfare Intersections with Thoroughfares or Arterials
ST-15B	Typical Striping for Thoroughfare Intersections with Collectors
ST-16	Typical Raised Island Designs for Limiting Access
ST-17	Typical Sections Streets Classes "A", "B", & "C"
ST-17A	Typical Sections Interim Improvements for Special Thoroughfare and Thoroughfare Streets with Rolled-In Rumble Strips
ST-17B	Rolled-In Rumble Strips for Interim Roadway Improvements
ST-17C	Rolled-In Rumble Strips for Interim Roadway Improvements
ST-17D	Typical Sections Interim Improvements for Special Thoroughfare and Thoroughfare Streets with Rolled-In Rumble Strips
ST-18	Class "C" Street Intersection
ST-19	Typical Street Sections at Residential Driveways
ST-20	Commercial Driveways Type A-6
ST-21B	Sidewalk Ramp for A-7 Driveways Without Additional R/W (Not for New Construction)
ST-22	Driveway Location Standards
ST-23	Cul-De-Sac
ST-24	Bulb-Out Detail
ST-25	90 Degree Intersection Elbow
ST-26.1	Minimum Sight Distance at Intersections and Non-Residential Driveways
ST-26.2	Visibility Requirements, City of Elk Grove
ST-27	Bus Turnouts
ST-28	Bus Stop Details
ST-30	A.C. Conforms to New Sidewalk Ramp Re-Construction

ST-31	Typical Curb and Gutter Sections
ST-32	Cross Gutter
ST-33	Barrier Curb Detail
ST-34	Under Sidewalk
ST-35	Separated (Or Detached) Sidewalk Transition
ST-36	A.C. Sidewalk Conform
ST-37	Residential Corner Lot Driveway Location Residential or Collector Streets
ST-38	Pavement Widening Detail
ST-39	Standard Concrete Joint Details
ST-40	Street Survey Monument
ST-41	Street Closure Timber Barricade
ST-42	Signs and Barricades at Abrupt Change of Pavement Width
ST-43	Sidewalk Barricade
ST-44	Multi-Use Trail Connections at Driveways and Intersections
ST-45	Multi-Use Mid Block Trail Connection
ST-46	Micro-Trenching

TRAFFIC

T-1	Stop Sign and Stop Legend Location
T-2A	Bollard Detail
T-2B	Asphalt Speed Hump Detail (W=26' – 34')
T-2C	Asphalt Speed Hump Detail (1) (W=26' – 34')
T-2D	Asphalt Speed Hump Detail (2) (W=36' – 44')
T-2E	Asphalt Speed Table Detail (W=26' – 44')
T-3	Street Name Sign
T-3.1	Veteran And Public Safety Street Name Sign
T-4	Private Street Name Sign
T-5A	Street Name Sign on Street Light Pole Placement Detail
T-5B	Street Name Sign on Electroliers
T-6A	Street Name Sign General Location
T-6B	Signs Post
T-6C	Sign Back Bracing
T-7	Bike Loop and Bike Legend Installation Detail
T-8A	Crosswalk at Uncontrolled Locations
T-8B	RRFB at Uncontrolled Locations
T-9A	Typical Street Cross Locations
T-9B	Typical Street Cross Sections 72', 96', and 118'
T-9C	Typical Street Cross Sections Frontage Road
T-9D	20-Foot Street (Private Alley)
T-10	Class C Street Cross Section

T-11	Pedestrian Lane with Bike Barrier
T-12	Concrete Foundation for Type P Controller Cabinet and Type III Service Cabinet
T-15	Conduit, Service Wire and Breaker Sizing
T-16	Typical Detector Loop Layouts
T-17	Type "B" Detector Handhole Detail
T-18	Interconnect Terminal Cabinet and Pedestrian Signal Controller Cabinet
T-19	Details Accessible Pedestrian Signal System
T-20	CCTV IP Dome Camera (Signal Pole Mounted)
T-21.1	Traffic Signal Mast Arm Sign Assembly (1 of 2)
T-21.2	Traffic Signal Mast Arm Sign Assembly (2 of 2)
T-22	Fiber Backbone Network

1) SIDEWALK TRANSITIONS

- A: LOCATED ADJACENT TO THE TOP OF RAMP AS NEEDED
- B: 48" MINIMUM WIDTH
- C: 1.5% (1:66) MAXIMUM CROSS SLOPE
- D: 4.5% (1:22) MAXIMUM PARALLEL SLOPE

2) LANDINGS

- A: LOCATED ABOVE OR BELOW RAMP (AS SHOWN IN DETAILS)
- B: 48" MINIMUM CLEAR SPACE IN ALL DIRECTIONS
- C: 1.5% (1:66) MAXIMUM PARALLEL AND CROSS SLOPE

3) RAMPS

- A: LOCATED ABOVE PAN OR BELOW LANDING
- B: 48" MINIMUM WIDTH
- C: 1.5% (1:66) MAXIMUM CROSS SLOPE
- D: 7.5% (1:13) MAXIMUM SLOPE
- E: ALL RAMPS SHALL HAVE A DETECTABLE WARNING SURFACE (TRUNCATED DOMES) AND SHALL BE PLACED ON THE RAMP UNLESS THE RAMP IS CONNECTED TO A PAN.
- F: TRANSITION TO GUTTER SHALL BE FLUSH AND FREE OF ABRUPT CHANGES
- G: GRADE BREAKS SHALL BE PERPENDICULAR TO DIRECTION OF RAMP RUN

4) PANS

- A: LOCATED BELOW RAMP (AS SHOWN IN DETAILS)
- B: 60" MINIMUM AT BACK OF PAN
- C: 54" MINIMUM FROM BACK OF PAN TO FLOW LINE
- D: 1.5% (1:66) MAXIMUM CROSS SLOPE
- E: ON CORNERS, PAN BOUNDARIES ARE TO BE RADIAL
- F: TRANSITIONS TO GUTTER SHALL BE FLUSH AND FREE OF ABRUPT CHARGES.
- G: ALL PANS SHALL HAVE A DETECTABLE WARNING SURFACE (TRUNCATED DOMES).

5) FLARES

- A: LOCATED ADJACENT TO RAMP (AS SHOWN IN DETAILS)
- B: REQUIRED BETWEEN RAMPS WHERE THERE IS NO PLANTER AREA
- C: REQUIRED ON THE EXTERIOR OF RAMPS WHERE THERE IS AN ADJACENT CONCRETE SIDEWALK, REGARDLESS OF OBSTACLES
- D: SHALL ALSO HAVE AT LEAST 24" LONG SEGMENT OF STRAIGHT CURB LOCATED ON EACH SIDE OF THE CURB RAMP AND WITHIN MARKED CROSSINGS.
- E: GENERALLY TRIANGULAR IN NATURE
- F: 9% (1:11) MAXIMUM SLOPE WHEN NOT IN THE PATH OF TRAVEL
- G: 7.5% (1:13) MAXIMUM SLOPE WHEN FLARE IS IN THE PATH OF TRAVEL

6) GUTTERS

- A: ADJACENT TO RAMP OR PAN
- B: 4.5% (1:22) MAXIMUM SLOPE FOR 4' OUT FROM FLOW LINE
- C: TRANSITION TO RAMP OR PAN SHALL BE FLUSH AND FREE OF ABRUPT CHANGES

7) RETAINING CURBS

- A: REQUIRED ADJACENT TO SIDEWALK TRANSITIONS, LANDINGS, RAMPS AND PANS WHERE THE EXISTING LANDSCAPE (PLANTER AREA) IS 1" OR HIGHER AT ANY POINT ABOVE THE NEWLY CONSTRUCTED CURB RAMP ELEMENT
- B: REQUIRED FOR EXISTING PLANTER AREAS BETWEEN RAMPS
- C: RETAINING CURBS ARE TO HAVE A 6" WIDTH AND A VERTICAL FACE
- D: RETAINING CURB FOUNDATIONS ARE TO EXTEND 8" BELOW THE ADJACENT RAMP ELEMENT SURFACE
- E: OUTSIDE CORNERS OF RETAINING CURBS MUST HAVE A 6" RADIUS

8) DETECTABLE WARNINGS

- A: PLACEMENT OF DETECTABLE WARNINGS SHALL BE PER DRAWINGS AR - 3.2A AND AR - 3.2B.
- B: 6"-8" FROM THE FLOW LINE
- C: 3' DEPTH X FULL WIDTH
- D: DETECTABLE WARNING REQUIREMENTS, SEE AR - 3.1

NOTES:

1. DIRECTIONAL CURB RAMPS ARE REQUIRED UNLESS OTHERWISE APPROVED BY THE ENGINEER.
2. ALL ELEMENTS, EXCEPT GUTTERS AND RETAINING CURBS, MUST BE CONSTRUCTED PLANAR IN NATURE WITH WEAKENED PLANE JOINTS SCORED BETWEEN EACH ELEMENT.
3. OPPOSING CURB RAMPS SHALL ALIGN UNLESS OTHERWISE APPROVED BY THE ENGINEER.
4. THESE ELEMENTS, DEFINITIONS AND STANDARDS, GENERAL DETAILS, AND STANDARD DRAWINGS SHALL APPLY TO ALL CURB AND GUTTER TYPES.
5. THERE ARE VARIATIONS AND ADJUSTMENTS THAT MAY BE REQUIRED UPON THE APPROVAL OF THE ENGINEER.
6. REFERENCES TO MAXIMUM CROSS SLOPE OF 1.5% ARE INTENDED TO ALLOW FOR NORMAL CONSTRUCTION TOLERANCES IN AN EFFORT TO KEEP THE ACTUAL CONSTRUCTED CROSS SLOPE TO LESS THAN THE REQUIRED ADA STANDARD OF 2.0% MAXIMUM CROSS SLOPE. ANY INSTALLATIONS OF CROSS SLOPES GREATER THAN 2.0% WILL BE UNACCEPTABLE.

DATE 09/22/2017		NOT TO SCALE	
REVISION	BY	APPROVED	DATE
01	LM	TW	07/18/2019
02	STN	JRW	02/16/2021

CITY OF ELK GROVE - PUBLIC WORKS

**CURB RAMP ELEMENTS
DEFINITIONS AND STANDARDS**

APPROVED BY:

Paul Minked 02/26/2021

CITY ENGINEER DATE

DRAWING NUMBER

AR - 2.0



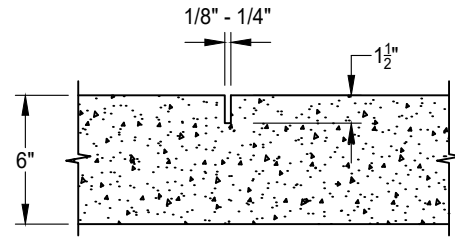
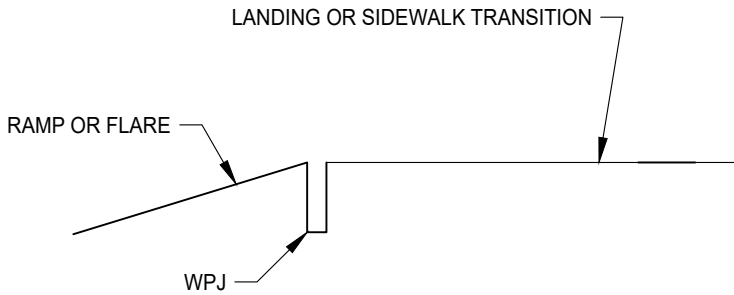

WEAKENED PLANE JOINT (WPJ)

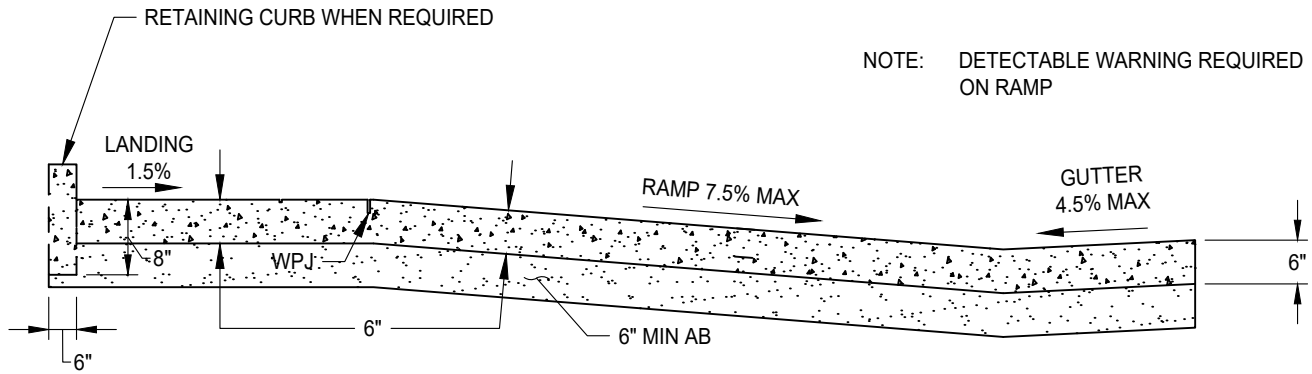

NOTE: DETECTABLE WARNING REQUIRED ON RAMP

TYPICAL CROSS SECTION FOR CENTER LINE OF FLARE, COMBO OR PLANTER STRIP CURB RAMP

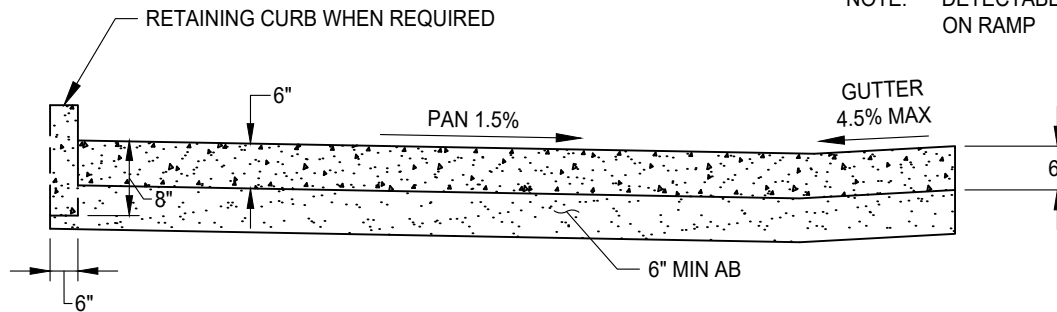

NOTE: DETECTABLE WARNING REQUIRED ON RAMP

TYPICAL CROSS SECTION FOR CENTER LINE OF PAN CURB RAMP

NOTES:

1. SURFACE OF RAMPS AND PANS SHALL HAVE A TRANSVERSE BROOM SURFACE TEXTURE ROUGHER THAN ADJACENT SIDEWALK.
2. COLORING SHALL BE ADDED TO NEW CONCRETE AS NECESSARY TO MATCH EXISTING COLOR.

DATE 09/22/2017		NOT TO SCALE	
REVISION	BY	APPROVED	DATE
01	LM	TW	07/18/2019
02	STN	JRW	02/16/2021

CITY OF ELK GROVE - PUBLIC WORKS

CURB RAMP GENERAL DETAILS

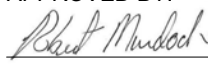
APPROVED BY:

 CITY ENGINEER DATE: 02/26/2021

DRAWING NUMBER
AR - 3.0



DETECTABLE WARNING SURFACES MUST MEET THE FOLLOWING CRITERIA:

1) A WRITTEN 5-YEAR PRODUCT WARRANTY FOR SHAPE, COLOR FASTNESS, SOUND-ON-CANE ACOUSTIC QUALITY, RESILIENCE, AND ATTACHMENT:

- A. SHAPE:
MUST BE ABLE TO RETAIN ITS ORIGINAL SHAPE WHEN SUBJECTED TO VARYING DEGREES OF TEMPERATURE, MOISTURE, PRESSURE, OR OTHER STRESS.
- B. COLOR FASTNESS:
THE ABILITY OF THE MATERIAL OR COATING TO RETAIN ITS ORIGINAL HUE WITHOUT FADING OR CHANGING WHEN EXPOSED TO ENVIRONMENTAL CONDITIONS.
- C. SOUND-ON-CANE ACOUSTIC QUALITY:
THE ABILITY OF A MATERIAL TO RETAIN ITS ORIGINAL SOUND CHARACTERISTICS WHEN IMPACTED BY AN OBJECT.
- D. RESILIENCE:
THE ABILITY OF THE MATERIAL TO ABSORB ENERGY WHEN DEFORMED ELASTICALLY WITHOUT CREATING A PERMANENT DEFORMATION.
- E. ATTACHMENT:
ATTACHMENT WILL NOT DEGRADE SIGNIFICANTLY FOR *AT LEAST FIVE (5) YEARS AFTER INITIAL INSTALLATION* - MEANING THE PRODUCT MAINTAINS AT LEAST 90% OF ORIGINAL PRODUCT AND BOND. BOLT DOWN PRODUCTS SHALL NOT BE USED.

2) CONFIRMATION - A WRITTEN DIMENSIONAL SPECIFICATION:

A WRITTEN DIMENSIONAL SPECIFICATION OF THE TRUNCATED DOMES AND RAISED BARS AS SPECIFIED IN THE CODES - SEE BELOW DIMENSIONS:

- A. BASE DIAMETER: 0.9" TO 0.92"
- B. TOP DIAMETER: 0.45" TO 0.47"
- C. CENTER-TO-CENTER SPACING 2.3" TO 2.4"
- D. HEIGHT: 0.18" TO 0.22"

3) LIGHT ON DARK OR DARK ON LIGHT:

70% CONTRAST WITH ADJOINING SURFACES - CONTRAST = $[(B1 - B2)/B1] \times 100$ PERCENT, WHERE B1 = LIGHT REFLECTANCE VALUE (LRV) OF THE LIGHTER AREA, B2 = LRV OF THE DARKER AREA.

4) METHODS OF INSTALLATIONS:

CAST-IN-PLACE (REQUIRED FOR ALL NEW CONSTRUCTION) OR SURFACE MOUNT (RETROFIT ONLY).

5) SIZE:

3' DEPTH BY FULL WIDTH.

6) COLOR:

COLOR SHALL BE DARK GRAY #36118 OF FED-STD-595 UNLESS SPECIFIED OTHERWISE.



DATE: 09/22/2017		NOT TO SCALE	
REVISION	BY	APPROVED	DATE
1	LM	TW	07-18-2019
2	SJB	SMA	05-08-2024

CITY OF ELK GROVE - PUBLIC WORKS

DETECTABLE WARNING SPECIFICATIONS

APPROVED BY: _____ 05-28-2024
CITY ENGINEER DATE

DRAWING NUMBER
AR - 3.1



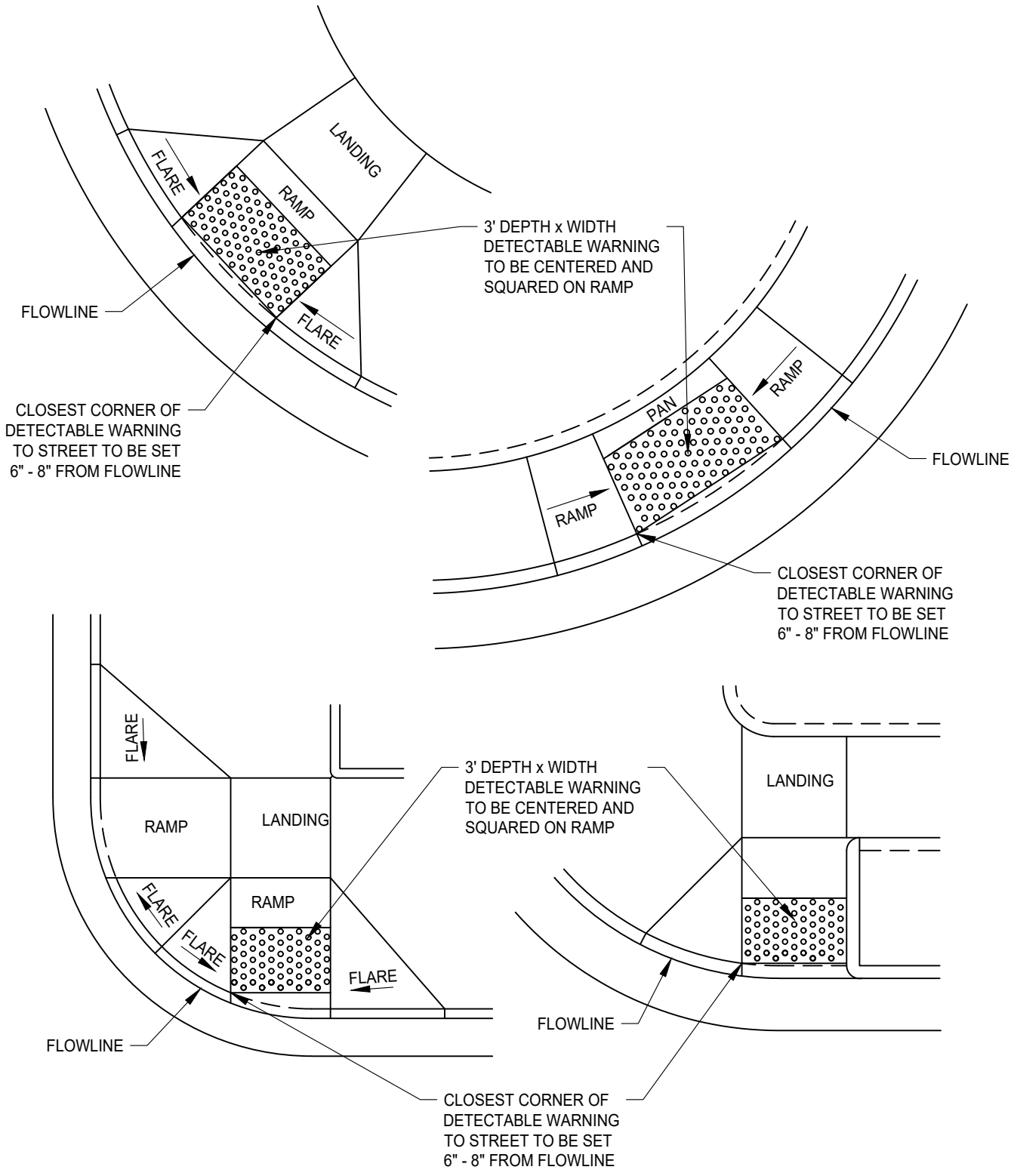

DATE: 09/22/2017		NOT TO SCALE	
REVISION	BY	APPROVED	DATE
01	LM	TW	07-18-2019

CITY OF ELK GROVE - PUBLIC WORKS

**DETECTABLE WARNING
STANDARD LAYOUT**

APPROVED BY:
Paul Muroch
CITY ENGINEER

1/16/2020
DATE

DRAWING NUMBER
AR - 3.2A



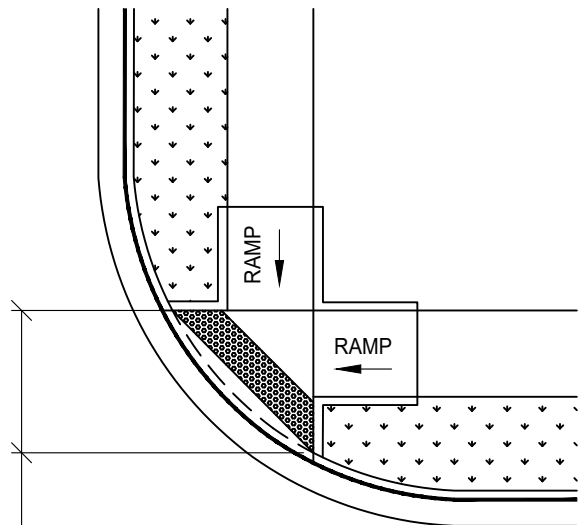
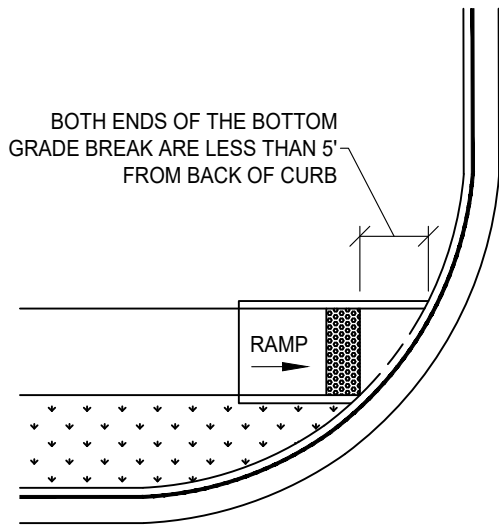

ONE OR BOTH ENDS OF THE BOTTOM GRADE BREAK ARE GREATER THAN 5' FROM BACK OF CURB

DATE: 09/22/2017		NOT TO SCALE	
REVISION	BY	APPROVED	DATE
01	LM	TW	07-18-2019

CITY OF ELK GROVE - PUBLIC WORKS

**DETECTABLE WARNING
STANDARD LAYOUT**

APPROVED BY:
Paul Murbach
CITY ENGINEER

1/16/2020
DATE

DRAWING NUMBER
AR - 3.2B



TRANSITION GUTTER CROSS SLOPE TO 4.5% ALONG TOTAL LENGTH OF AREA OF RAMPED PORTION (TYP.)

NOTES:

1. ALL SLOPES SHOWN ARE MAXIMUMS.
 2. ALL DIMENSIONS SHOWN ARE MINIMUMS.
 3. ALL PANS MUST BE LOCATED INSIDE CROSSWALKS OR IN FRONT OF STOP BARS.
 4. DETECTABLE WARNING IS PLACED IN THE PAN AS PER DRAWING AR-3.2.
 5. ALL JOINTS BETWEEN ELEMENTS ARE RADIAL.
 6. DRAIN INLET SHALL NOT BE INSTALLED WITHIN THE LIMITS OF THE CURB RAMP INCLUDING PAN, RAMP, AND SIDEWALK TRANSITION AREAS.
 7. SEE IMPROVEMENT STANDARDS SECTION 9-14.H FOR INSTALLING DRAINAGE INLETS NEXT TO CURB RAMPS.
- ** SLOPE 1% MINIMUM TO 1.5% MAXIMUM FROM BACK OF PAN TO FLOW LINE.
- (A) 4" MINIMUM CURB HEIGHT, UNLESS OTHERWISE APPROVED BY THE ENGINEER
- (B) FROM THE FLOW LINE OUT THE RUNNING SLOPE CANNOT EXCEED 4.5% FOR A DISTANCE OF 4'.

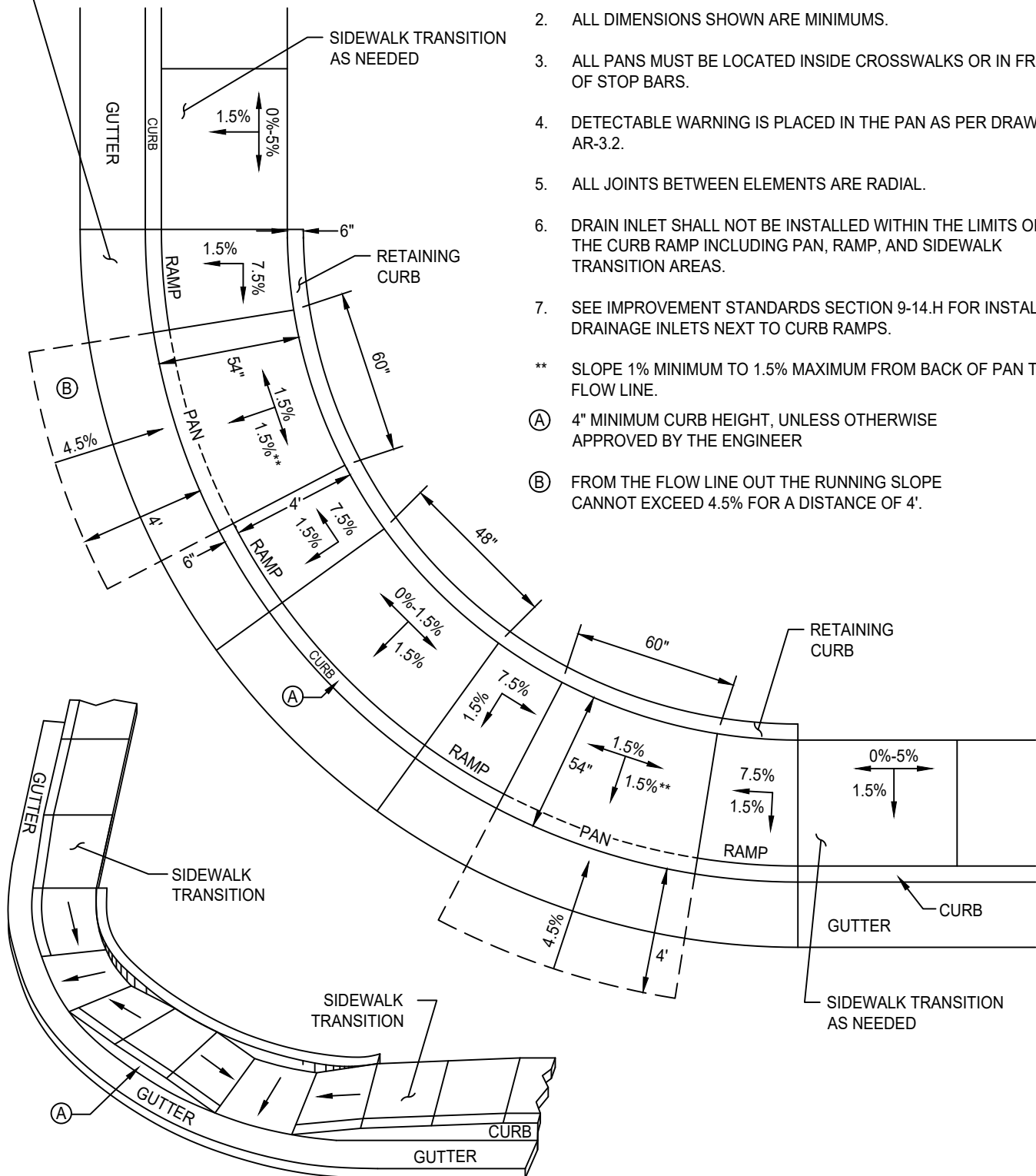

DATE: 09/22/2017		NOT TO SCALE	
REVISION	BY	APPROVED	DATE
1	LM	TW	07-18-2019
2	SJB	SMA	02-23-2024

CITY OF ELK GROVE - PUBLIC WORKS

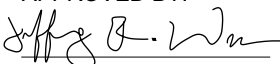
APPROVED BY:

 CITY ENGINEER DATE: 03-12-2024

DUAL PARALLEL CURB RAMPS



DRAWING NUMBER

AR - 4.1

NOTES:

1. ALL SLOPES SHOWN ARE MAXIMUMS.
 2. ALL DIMENSIONS SHOWN ARE MINIMUMS.
 3. ALL PANS MUST BE LOCATED INSIDE CROSSWALKS OR IN FRONT OF STOP BARS.
 4. DETECTABLE WARNING IS PLACED IN THE PAN AS PER DRAWING AR-3.2.
 5. ALL JOINTS BETWEEN ELEMENTS ARE RADIAL.
 - ** SLOPE 1% MINIMUM TO 1.5% MAXIMUM FROM BACK OF PAN TO FLOW LINE.
- (A) FROM THE FLOW LINE OUT THE RUNNING SLOPE CANNOT EXCEED 4.5% FOR A DISTANCE OF 4'.
- (B) 56" FOR TYPE 2 CURB
58" FOR TYPE 1A CURB

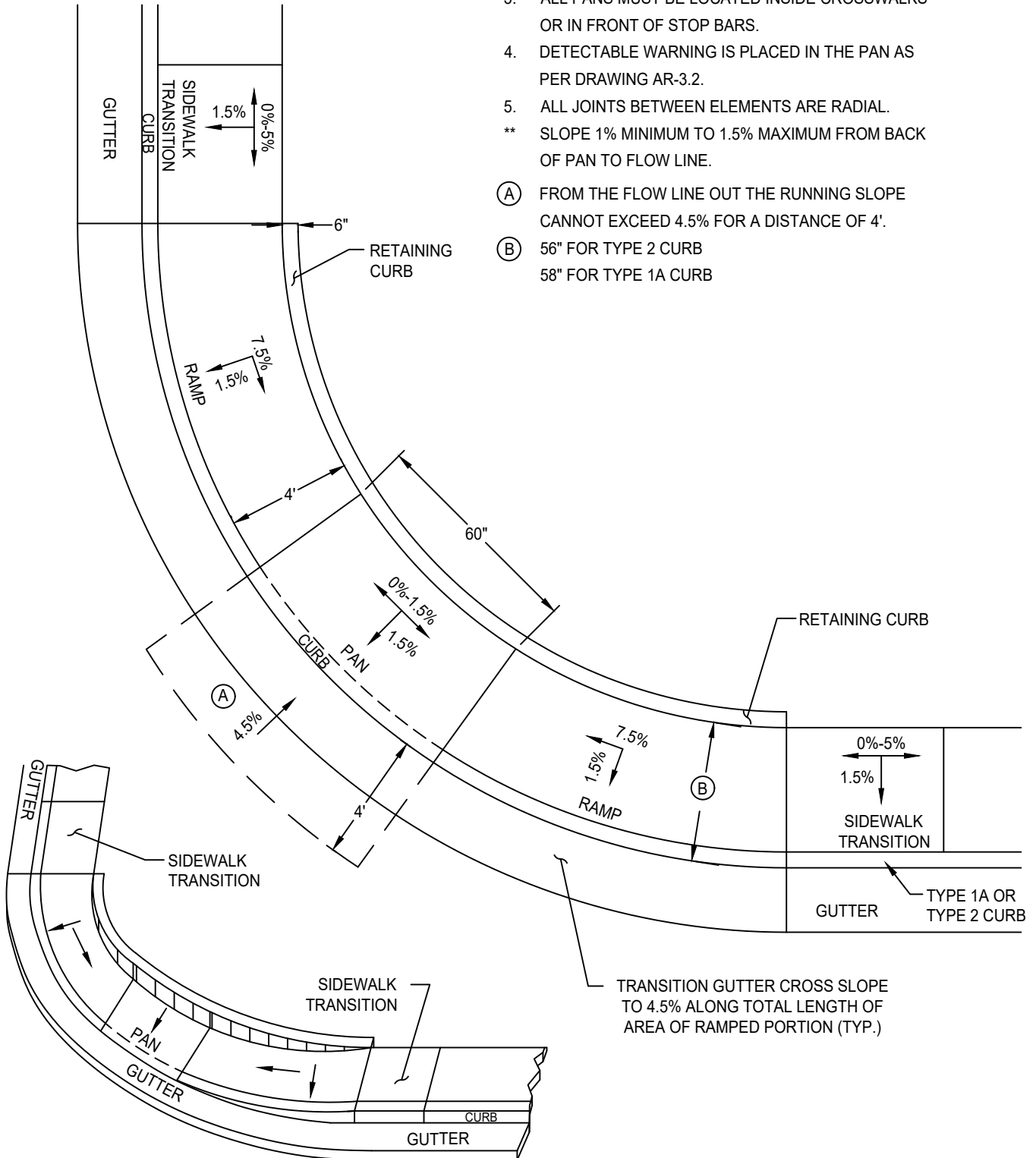

DATE: 04/25/2023		NOT TO SCALE	
REVISION	BY	APPROVED	DATE

CITY OF ELK GROVE - PUBLIC WORKS

**SINGLE PARALLEL CURB RAMP
FOR UNCONTROLLED
T-INTERSECTIONS**

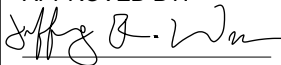
APPROVED BY:

 CITY ENGINEER DATE: 04-25-2023

DRAWING NUMBER
AR - 4.2

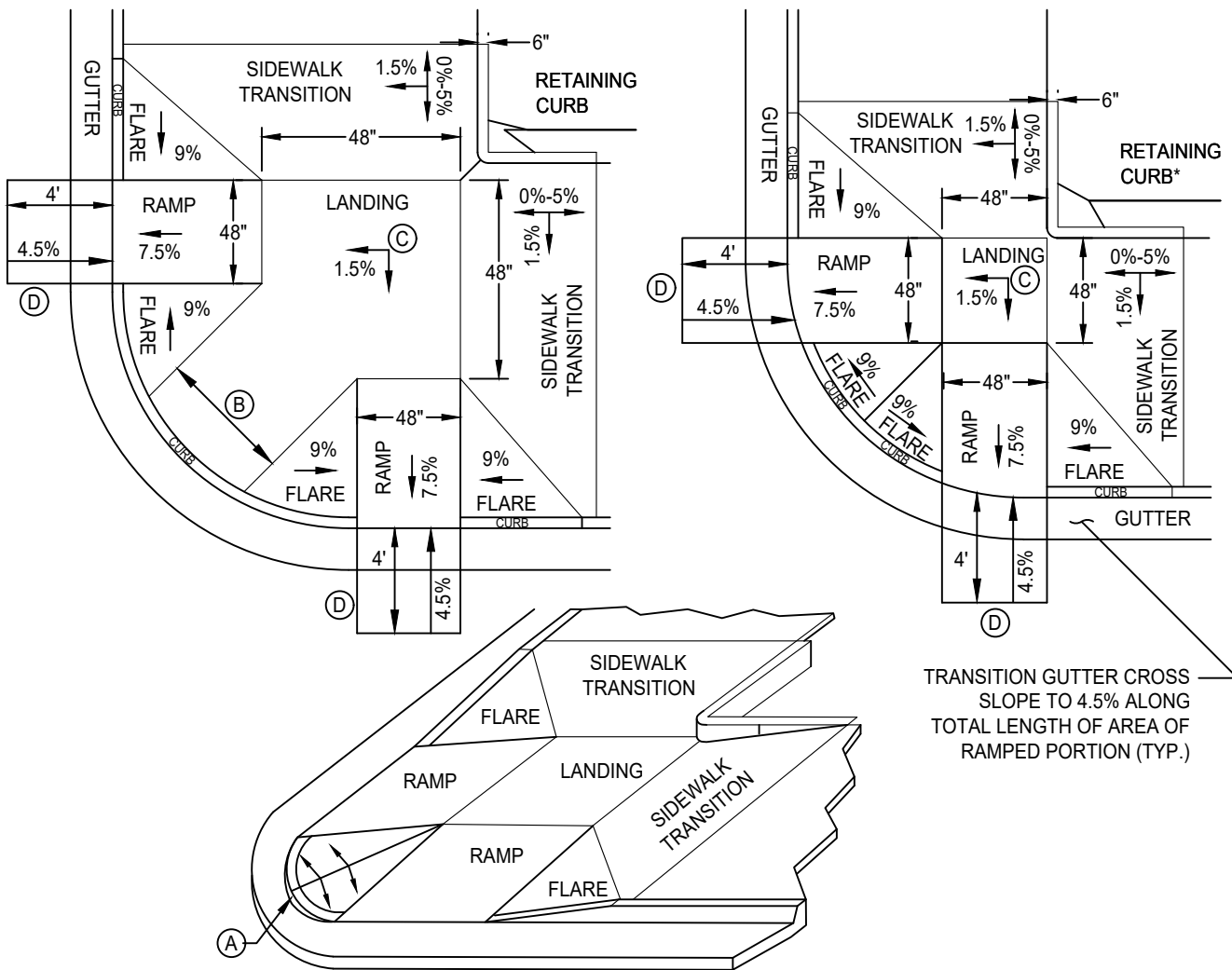

NOTES:

1. ALL SLOPES SHOWN ARE MAXIMUMS.
 2. ALL DIMENSIONS SHOWN ARE MINIMUMS.
 3. THE RAMP MUST BE LOCATED INSIDE CROSSWALKS OR PRIOR TO STOP BARS.
 4. DETECTABLE WARNING SURFACE IS PLACED IN THE RAMP PER STANDARD DRAWING AR-3.2A and AR-3.2B.
 5. IF THE FLARE IS IN THE PATH OF TRAVEL THEN THE SLOPE SHALL NOT EXCEED 7.5%.
- (A) 4" MINIMUM CURB HEIGHT DESIRABLE - 9% MAX SLOPE CONTROLS CURB HEIGHT, UNLESS OTHERWISE APPROVED BY THE ENGINEER.
- (B) NO MINIMUM DIMENSION. FLARES CAN INTERSECT.
- (C) ALL RAMPS WILL HAVE A MINIMUM OF 48" x 48" LANDING. TWO RAMPS CAN SHARE ONE LANDING.
- (D) FROM THE FLOW LINE OUT THE RUNNING SLOPE CANNOT EXCEED 4.5% FOR A DISTANCE OF 4'.



DATE 09/22/2017		NOT TO SCALE	
REVISION	BY	APPROVED	DATE
1	LM	TW	07/18/2019
2	STN	JRW	02/16/2021
3	SJB	SMA	03-13-2024

CITY OF ELK GROVE - PUBLIC WORKS

**DUAL FLARE CURB RAMPS
WITH ATTACHED SIDEWALK**

APPROVED BY: _____ 05-28-2024
CITY ENGINEER DATE

DRAWING NUMBER
AR - 4.3



NOTES:

- A. ALL SLOPES SHOWN ARE MAXIMUMS.
- B. ALL DIMENSIONS SHOWN ARE MINIMUMS.
- C. RAMP MUST BE LOCATED INSIDE CROSSWALKS OR IN FRONT OF STOP BARS
- D. DETECTABLE WARNING SURFACE IS PLACED IN THE RAMP PER STANDARD DRAWING AR-3.2A AND AR-3.2B.
- E. ALL JOINTS BETWEEN ELEMENTS, EXCEPT BETWEEN RAMP AND FLARE ARE RADIAL. RAMP WIDTH REMAINS CONSTANT.
- F. IF THE FLARE IS IN THE PATH OF TRAVEL THEN THE SLOPE SHALL NOT EXCEED 7.5%.
- G. SINGLE RAMPS SHALL BE CONSTRUCTED PARALLEL TO CROSSING DIRECTION.

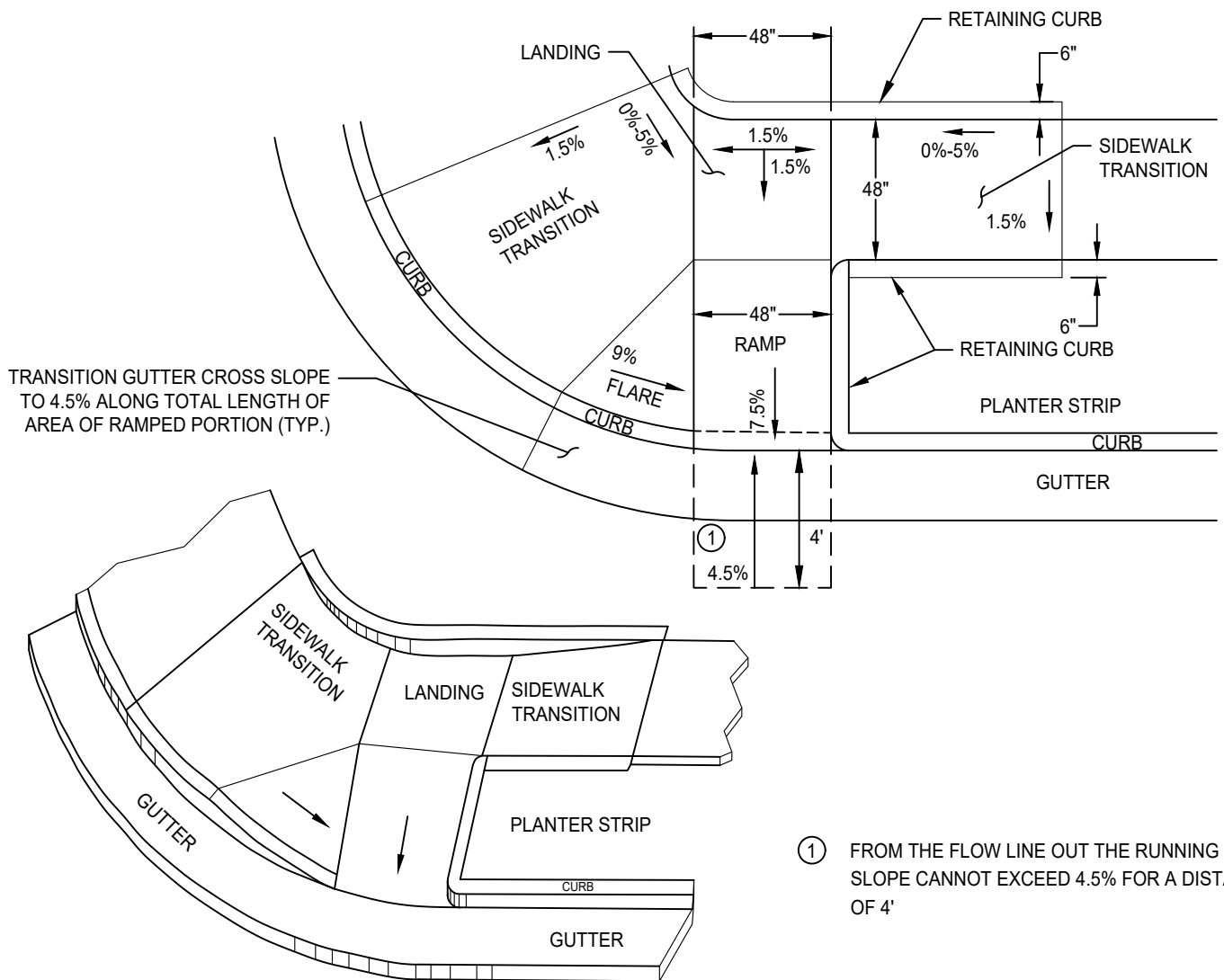

DATE: 09/22/2017		NOT TO SCALE	
REVISION	BY	APPROVED	DATE
1	LM	TW	07-18-2019
2	SJB	SMA	03-13-2024

CITY OF ELK GROVE - PUBLIC WORKS

SINGLE PERPENDICULAR CURB RAMP

APPROVED BY: _____ 05-28-2024
CITY ENGINEER DATE

DRAWING NUMBER
AR - 4.4



NOTES:

1. ALL SLOPES SHOWN ARE MAXIMUMS.
 2. ALL DIMENSIONS SHOWN ARE MINIMUMS.
 3. THE RAMP MUST BE LOCATED INSIDE CROSSWALKS OR IN FRONT OF STOP BARS.
 4. DETECTABLE WARNING IS PLACED IN THE RAMP AND AS PER DRAWING AR-3.2A AND AR-3.2B.
 5. IF THE FLARE IS IN THE PATH OF TRAVEL THEN THE SLOPE SHALL NOT EXCEED 7.5%.
- (A) 4" MINIMUM CURB HEIGHT DESIRABLE - 9% MAX SLOPE CONTROLS CURB HEIGHT, UNLESS OTHERWISE APPROVED BY THE ENGINEER.
- (B) NO MINIMUM DIMENSION. FLARES CAN INTERSECT.
- (C) ALL RAMPS WILL HAVE A MINIMUM OF 48" x 48" LANDING. TWO RAMPS CAN SHARE ONE LANDING.
- (D) FROM THE FLOW LINE OUT THE RUNNING SLOPE CANNOT EXCEED 4.5% FOR A DISTANCE OF 4'.

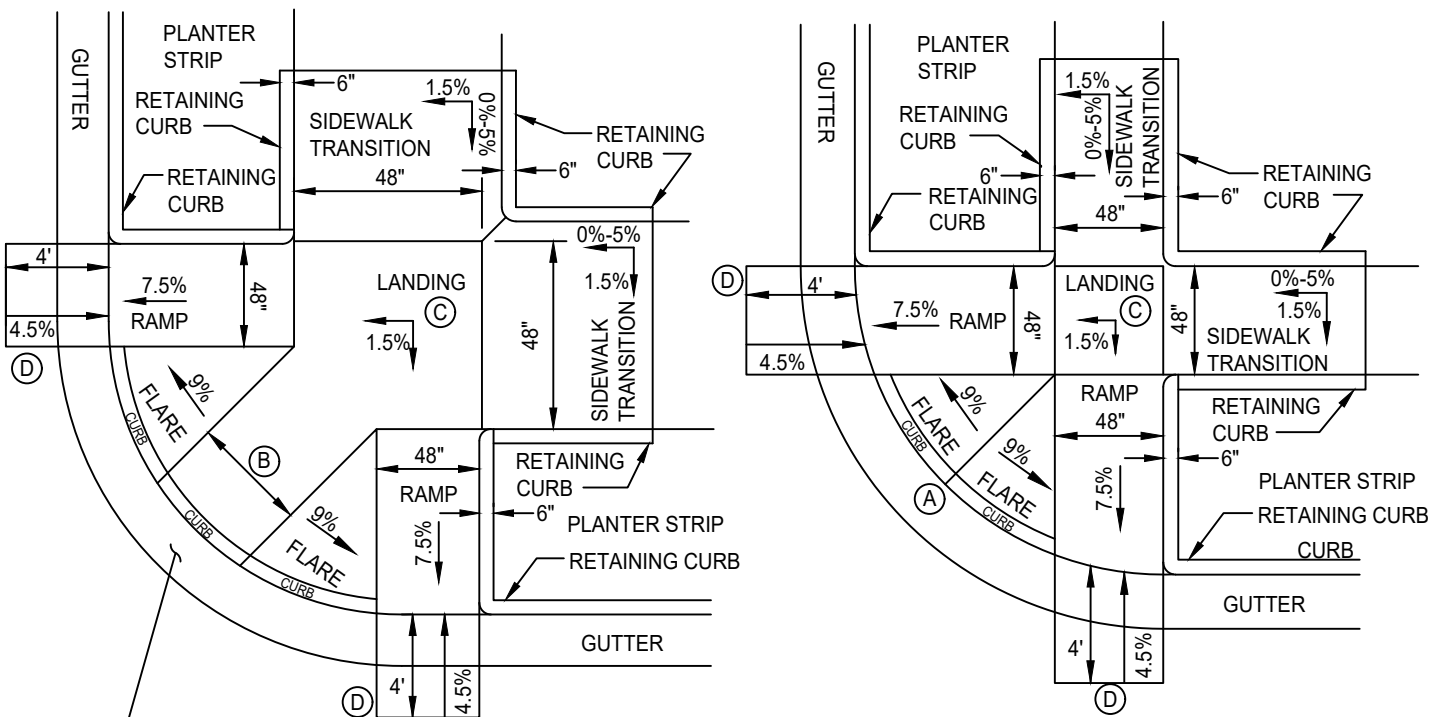

TRANSITION GUTTER CROSS SLOPE TO 4.5% ALONG TOTAL LENGTH OF AREA OF RAMPED PORTION (TYP.)

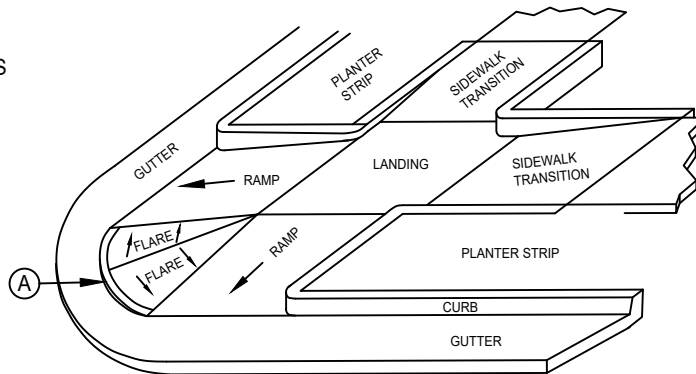

DATE 09/22/2017		NOT TO SCALE	
REVISION	BY	APPROVED	DATE
1	LM	TW	07/18/2019
2	STN	JRW	02/16/2021
3	SJB	SMA	03-13-2024

CITY OF ELK GROVE - PUBLIC WORKS

DUAL FLARED PERPENDICULAR CURB RAMPS WITH DETACHED SIDEWALK

APPROVED BY: _____ 05-28-2024
 CITY ENGINEER DATE

DRAWING NUMBER
AR - 4.5



NOTES:

1. ALL SLOPES SHOWN ARE MAXIMUMS.
 2. ALL DIMENSIONS SHOWN ARE MINIMUMS.
 3. ALL RAMPS MUST BE LOCATED INSIDE CROSSWALKS OR IN FRONT OF STOP BARS.
 4. DETECTABLE WARNING IS PLACED IN THE RAMP AND AS PER DRAWING AR-3.2A AND AR-3.2B.
 5. ADD LAMP BLACK TO NEW CONCRETE AS DIRECTED BY ENGINEER. MATCH EXISTING COLOR.
- (A) STANDARD CURB HEIGHT TO MATCH EXISTING.
- (B) TOP OF RETAINING CURB TO MATCH ADJACENT RETAINING CURB ELEVATIONS CAN BE FLUSH WITH LANDING.
- (C) FROM THE FLOW LINE OUT THE RUNNING SLOPE CANNOT EXCEED 4.5% FOR A DISTANCE OF 4'.

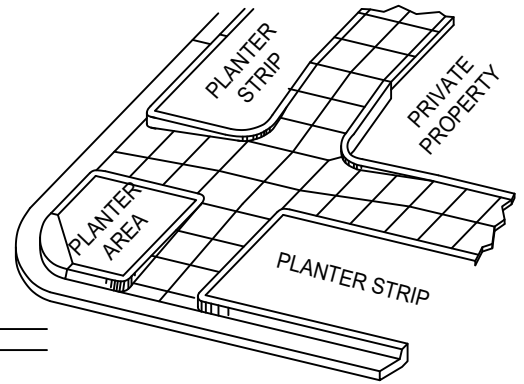
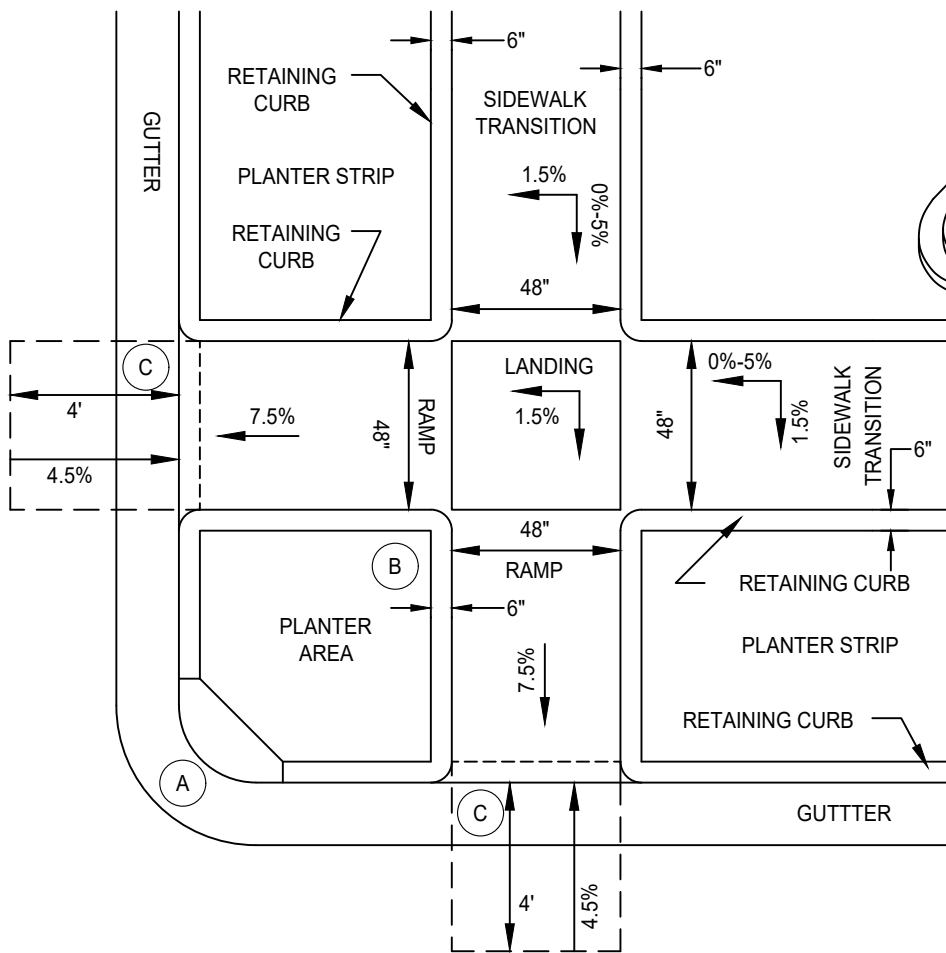

DATE: 09/22/2017		NOT TO SCALE	
REVISION	BY	APPROVED	DATE
1	LM	TW	07-18-2019
2	SJB	SMA	03-13-2024

CITY OF ELK GROVE - PUBLIC WORKS

**DUAL PERPENDICULAR CURB
RAMPS WITH DETACHED SIDEWALK**

APPROVED BY: _____ 05-28-2024
CITY ENGINEER DATE

DRAWING NUMBER
AR - 4.6



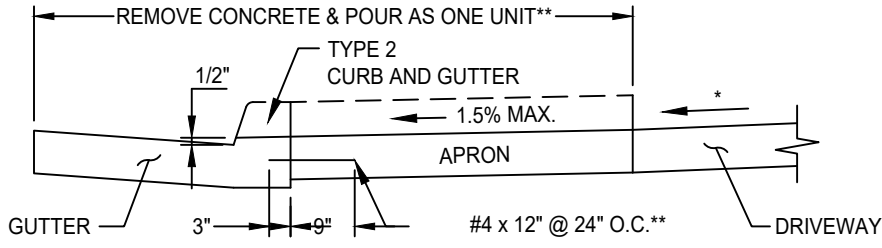
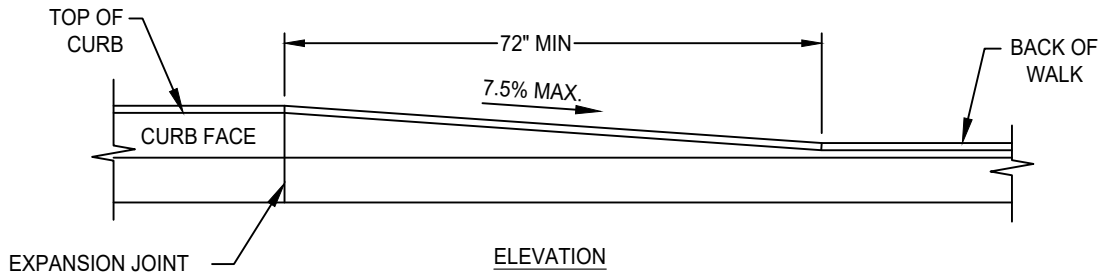

SECTION A-A

NOTES:

- A. DRIVEWAY WIDTH AS PER CITY CODE.
- B. WEAKENED PLANE JOINTS (WPJ) REQUIRED ON CENTERLINE FOR DRIVEWAYS 10' TO 20' WIDE. DRIVEWAYS 22' TO 35' WIDE SHALL HAVE TWO WPJ EVENLY SPACED AT 1/3 AND 2/3 POINTS.
- C. THICKNESS OF APRONS SHALL BE 6" ON RESIDENTIAL AND COMMERCIAL DRIVEWAYS.
- D. APRON WILL BE DEPRESSED ON CURB AND GUTTER WHEN RECONSTRUCTING EXISTING COMMERCIAL DRIVEWAYS.
- * SEE SECTION 4-7 OF THE IMPROVEMENT STANDARDS
- ** IF CURB & GUTTER ARE POURED SEPARATE OF APRON THEN DOWELS ARE REQUIRED AT BACK OF CURB.

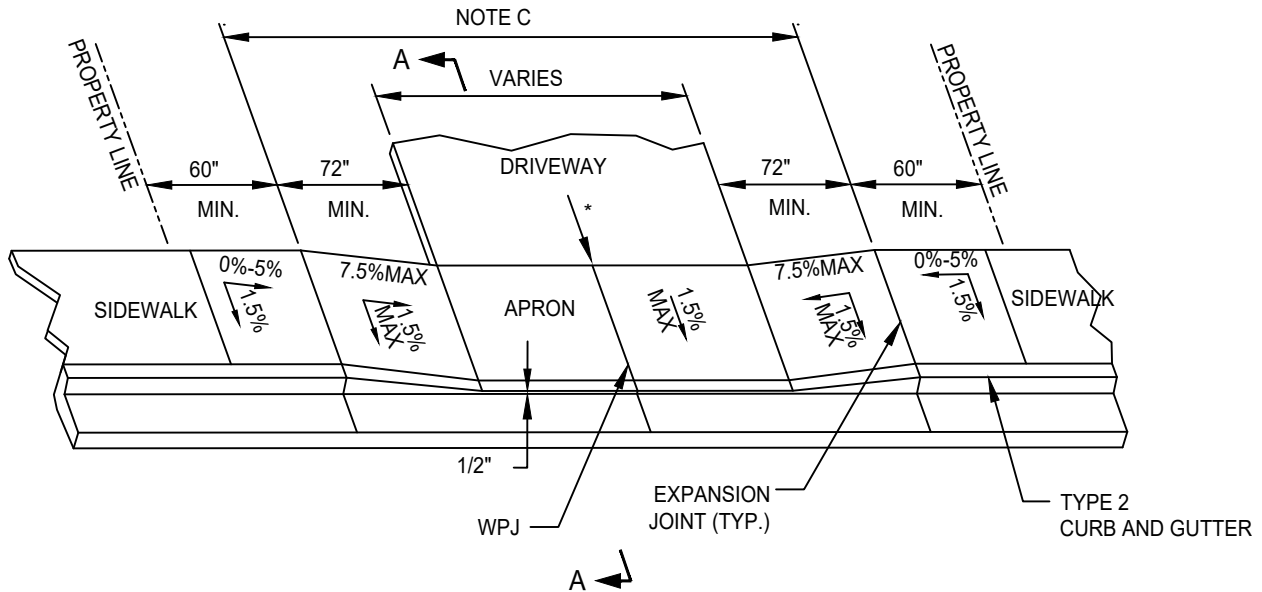

DATE 09/22/2017		NOT TO SCALE	
REVISION	BY	APPROVED	DATE
1	STN	JRW	02/16/2021

CITY OF ELK GROVE - PUBLIC WORKS

SIDEWALK DRIVEWAY DETAIL

APPROVED BY:
Paul Murbach
CITY ENGINEER

02/26/2021
DATE

DRAWING NUMBER
AR - 4.7



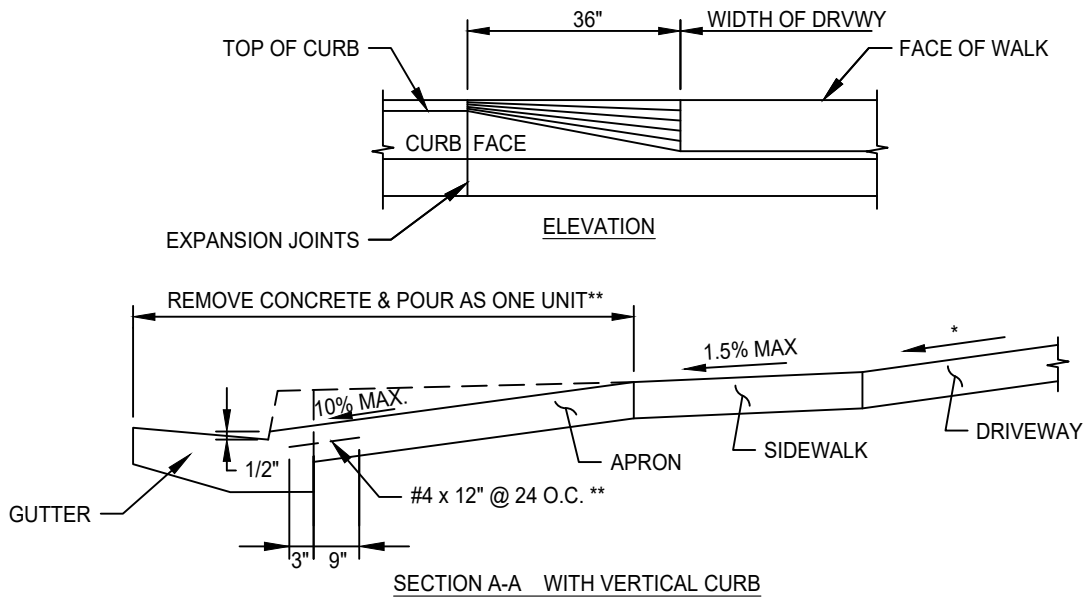

NOTES:

- A. DRIVEWAY WIDTH AS PER CITY CODE. * SEE SECTION 4-7 OF THE IMPROVEMENT STANDARDS
- B. WEAKENED PLANE JOINTS (WPJ) REQUIRED ON CENTERLINE FOR DRIVEWAYS 10' TO 20' WIDE. DRIVEWAYS 22' TO 35' WIDE SHALL HAVE TWO WPJ EVENLY SPACED AT 1/3 AND 2/3 POINTS. ** IF CURB & GUTTER ARE POURED SEPARATE OF APRON THEN DOWELS ARE REQUIRED AT BACK OF CURB.
- C. THICKNESS OF DRIVEWAYS AND APRONS SHALL BE 6".

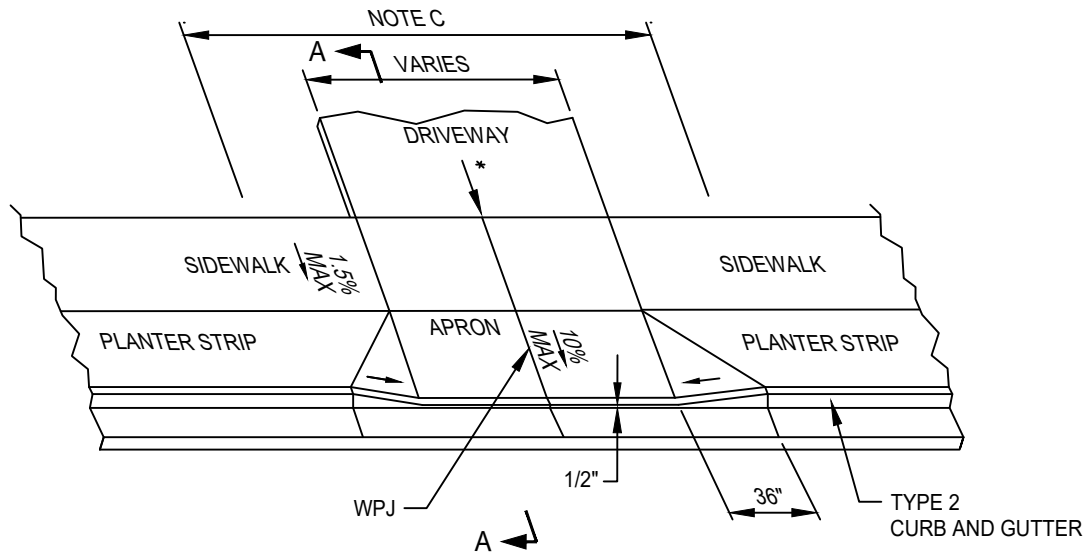

DATE 09/22/2017		NOT TO SCALE	
REVISION	BY	APPROVED	DATE
1	STN	JRW	02/16/2021
2	SJB	SMA	03-13-2024

CITY OF ELK GROVE - PUBLIC WORKS

DETACHED SIDEWALK DRIVEWAY DETAIL

APPROVED BY: _____ 05-28-2024
CITY ENGINEER DATE

DRAWING NUMBER
AR - 4.8



CITY OF ELK GROVE PLAN APPROVAL BLOCK

PLAN REVISION BLOCK

CITY OF ELK GROVE COMMUNITY DEVELOPMENT DEPARTMENT	
<i>(PUT PROJECT NAME HERE)</i>	
Parcel No.:	
Facility Code:	County Drainage Fee Paid:
City's Project No.:	
Accepted By:	
CITY OF ELK GROVE COMMUNITY DEVELOPMENT DEPARTMENT	DATE

Rev. No.	Description	Engr Init.	CITY ACCEPTANCE	
			By	Date

← 1.5" MIN →

← 1" MIN →

← 0.5" MIN →

1. PROJECT NAME, PARCEL NUMBER AND MAP COORDINATES SHALL BE IN 10 POINT ARIAL FONT.
2. APPROVAL BLOCK SHALL BE LOCATED AT THE LOWER RIGHT CORNER OF TITLE SHEET, WITHIN BOTTOM 6 INCHES AND RIGHT 8 INCHES OF PAGE.

1. PLACE REVISION BLOCK AT THE BOTTOM OF ALL SHEETS.

OTHER AGENCY APPROVAL BLOCKS

INCLUDE ON PLANS AS NECESSARY

Approved By:
COSUMNES FIRE DEPARTMENT
DATE

Approved By:
COSUMNES CSD LANDSCAPE ARCHITECTURE & PLANNING
DATE

Approved By:
SACRAMENTO AREA SEWER DISTRICT
DATE

Approved By:
WATER AGENCY NAME
DATE

1. PUT "SACRAMENTO COUNTY WATER AGENCY" OR "ELK GROVE WATER SERVICE" OR BOTH IN PLACE OF "WATER AGENCY NAME" ABOVE.

DATE 09/22/2017		NOT TO SCALE	
REVISION	BY	APPROVED	DATE
1	STN	SA	06-20-2023
2	SJB	SMA	11-21-2025

CITY OF ELK GROVE - PUBLIC WORKS

APPROVAL BLOCKS

APPROVED BY:	
 CITY ENGINEER	11-21-2025 DATE
DRAWING NUMBER	
D - 1	

DRAFTING STANDARDS

ALL SUBDIVISION PLANS, CONSTRUCTION DRAWINGS, & PROPERTY PLATS SUBMITTED TO THE CITY ENGINEER FOR CONSIDERATION SHALL CONFORM TO AND BE PREPARED IN ACCORDANCE WITH THE FOLLOWING STANDARDS:

1. ALL LETTERING, OTHER THAN THAT HEREIN SPECIFIED OR SHOWN BELOW, SHALL BE A MINIMUM OF 0.100 INCH IN HEIGHT AND USING 0.01" LINE WIDTH, OR EQUAL.

2. SUBDIVISION PLANS

	<u>LINE WIDTH</u>	
STREET CENTER LINES	—————	0.01" WIDTH
RADIAL BEARING LINES	—————	0.01" WIDTH
EASEMENT LINES	—————	0.01" WIDTH
LOT LINES	—————	0.02" WIDTH
RIGHT-OF-WAY LINES	—————	0.03" WIDTH
BLOCK OUTLINE	—————	0.03" WIDTH
SUBDIVISION OUTLINE	—————	0.04" WIDTH
MONUMENTS SET	○	
MONUMENTS SET IN MONUMENT BOX	⊙	
MONUMENTS FOUND	⊗	
MONUMENTS FOUND IN MONUMENT BOX	⊗	
BENCH MARK ELEVATION	⊕	
STREET NAMES	NAME	LETTERS 0.175" HIGH AND 0.04" LINE WIDTH
LOT NUMBERS	36	LETTERS 0.175" HIGH AND 0.02" LINE WIDTH
BEARINGS, DISTANCES, CURVE DATA, COORDINATES, ETC.		LETTERS 0.100" HIGH AND 0.01" LINE WIDTH
ADJACENT SUBDIVISIONS		LETTERS 0.175" HIGH AND SHADOW LETTERING AND 0.01" LINE WIDTH
ADJACENT LOT NUMBERS		LETTERS 0.175" HIGH AND DOTTED LETTERING AND 0.01" LINE WIDTH

TITLE BLOCK AND OTHER RELATED LETTERING SHALL BE IN ACCORDANCE WITH STANDARD ACCEPTED ENGINEERING PRACTICE, BUT IN NO CASE SHALL THE LETTERING BE LESS THAN 0.100 INCH IN HEIGHT AND USING LINE WIDTH OF 0.01".

3. IMPROVEMENT PLANS

<u>DESCRIPTION</u>	<u>PROPOSED</u>	<u>EXISTING</u>
SANITARY SEWER	————— 6" SS —————	————— 6" SS —————
STORM SEWER (AKA STORM DRAIN)	————— 8" SD —————	————— 8" SD —————
GAS LINE	————— 4" G —————	————— 4" G —————
WATER LINE	————— 8" W —————	————— 8" W —————
TELEPHONE	————— T —————	————— T —————
CABLE TELEVISION	————— TV —————	————— TV —————
GAS VALVE	————— G ⊗ —————	————— G —————
WATER VALVE	————— W ⊗ —————	————— W —————
ELECTRICAL CONDUIT	————— E —————	————— E —————
MATCH LINE	—————	
	STA. 5+00	

DATE 09/22/2017		NOT TO SCALE	
REVISION	BY	APPROVED	DATE
01	STN	JRW	02/16/2021

CITY OF ELK GROVE - PUBLIC WORKS

DRAFTING STANDARDS

APPROVED BY: *Robert M. ...* 02/26/2021

CITY ENGINEER DATE

DRAWING NUMBER

D - 2



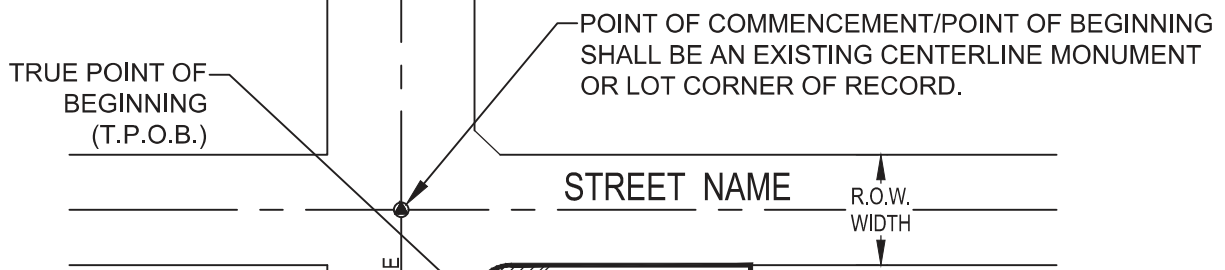
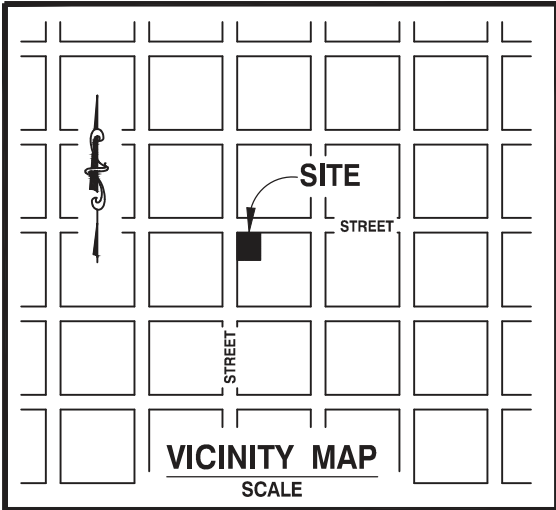

- MAP SHALL INCLUDE:
- STREET NAMES
 - RIGHT-OF-WAY AND EASEMENT WIDTHS DIMENSIONED
 - PROJECT LIMITS CLEARLY SHOWN
 - CITY-COUNTY BOUNDARIES AND SECTION LINES SHOWN WHERE APPLICABLE
 - NORTH ARROW AND SCALE
 - BASIS OF BEARING

- SHALL INCLUDE:
- LOT/PARCEL NO.
 - AREA
 - BEARINGS & DISTANCES
 - CURVE DATA--RADIUS, CENTRAL ANGLE, ARC LENGTH, CHORD BEARING, & CHORD LENGTH
 - EXISTING EASEMENTS SHOWN AND DIMENSIONED
 - EXISTING CENTERLINE MONUMENTS
 - OFFICIAL RECORD INFORMATION

NOTES:

1. DRAFTING STANDARDS AND SYMBOLS SHALL CONFORM TO CITY OF ELK GROVE STANDARDS.
2. CLOSURE CALCULATIONS, INCLUDING AREA AND PRECISION, SHALL BE SUBMITTED SEPARATELY.
3. LEGAL DESCRIPTIONS SUBMITTED WITH THE MAP SHALL BE STAMPED AND SIGNED BY A REGISTERED PROFESSIONAL ENGINEER OR LICENSED LAND SURVEYOR.

PREPARED BY:

 (ENGINEERING FIRM)

DATE: 09/22/2017		NOT TO SCALE	
REVISION	BY	APPROVED	DATE

CITY OF ELK GROVE - PUBLIC WORKS

**STANDARD MAP ASSOCIATED
WITH LEGAL DESCRIPTION FOR
8-1/2 " x 11" SHEET**

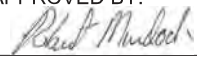
APPROVED BY:

 10/24/2018
 CITY ENGINEER DATE

DRAWING NUMBER
D - 3

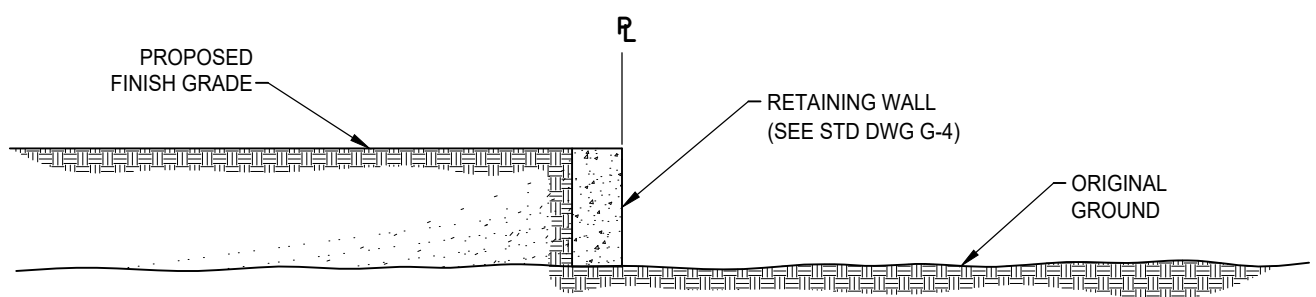
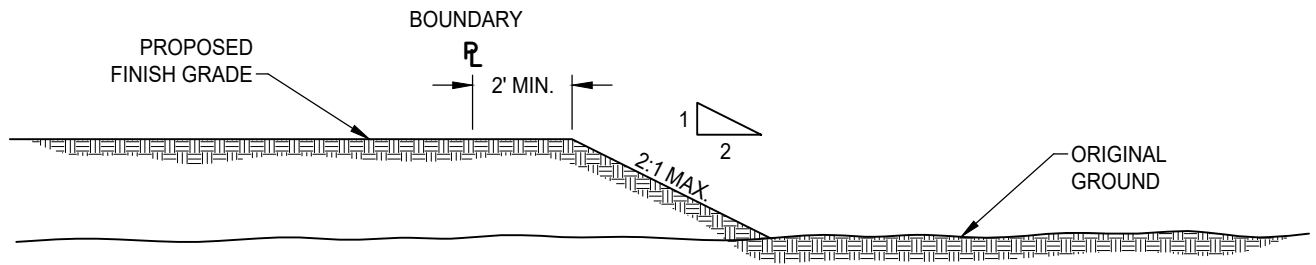





DATE 09/22/2017		NOT TO SCALE	
REVISION	BY	APPROVED	DATE
01	STN	JRW	02/16/2021

CITY OF ELK GROVE - PUBLIC WORKS

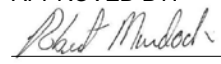
**EXTERIOR PERIMETER
PROPERTY LINE GRADING FOR
FILL AREAS**

APPROVED BY:

 CITY ENGINEER DATE
 02/17/2021

DRAWING NUMBER
G - 1

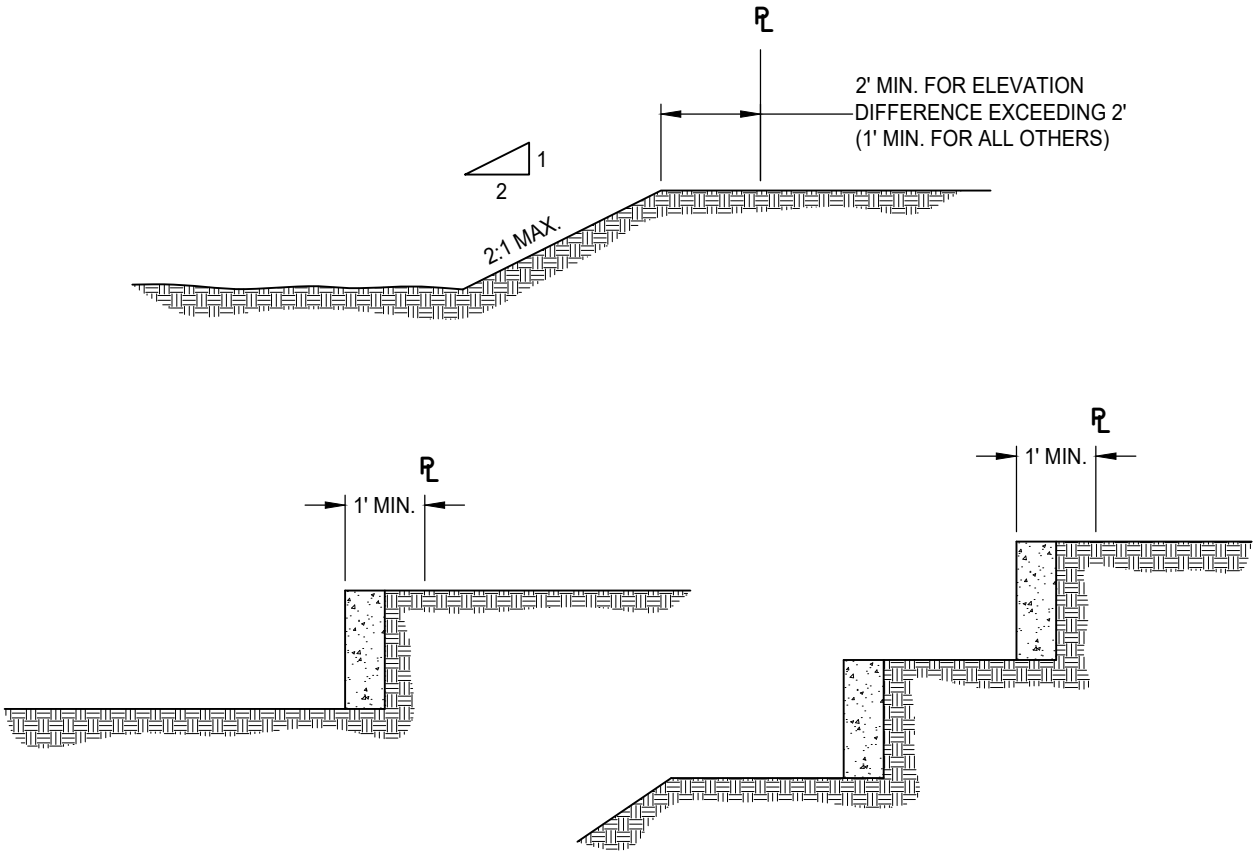

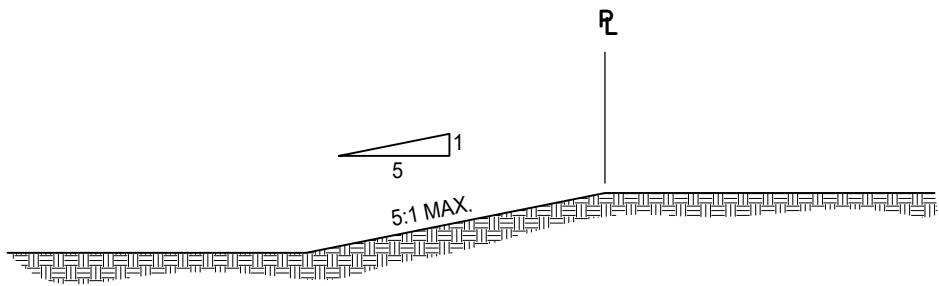

RETAINING WALL
 (SEE STD DWG G-3 AND G-4)
NOTE: NO DOUBLE RETAINING WALLS SHALL BE CONSTRUCTED ON SIDE YARD



DATE: 09/22/2017
 NOT TO SCALE

CITY OF ELK GROVE - PUBLIC WORKS

APPROVED BY: *Paul Murock*
 CITY ENGINEER 10/24/2018
 DATE

REVISION	BY	APPROVED	DATE

GRADING FOR INTERIOR PROPERTY LINES AND PERIMETER PROPERTY LINES IN CUT AREAS

DRAWING NUMBER
G - 2



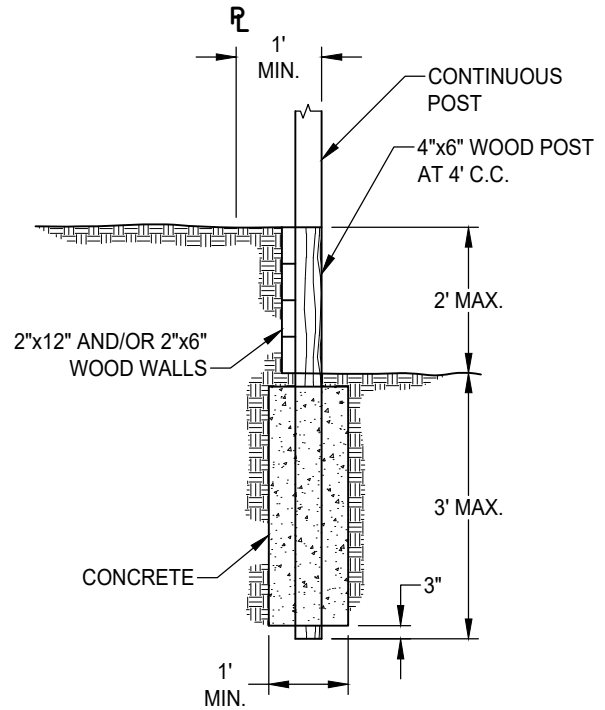
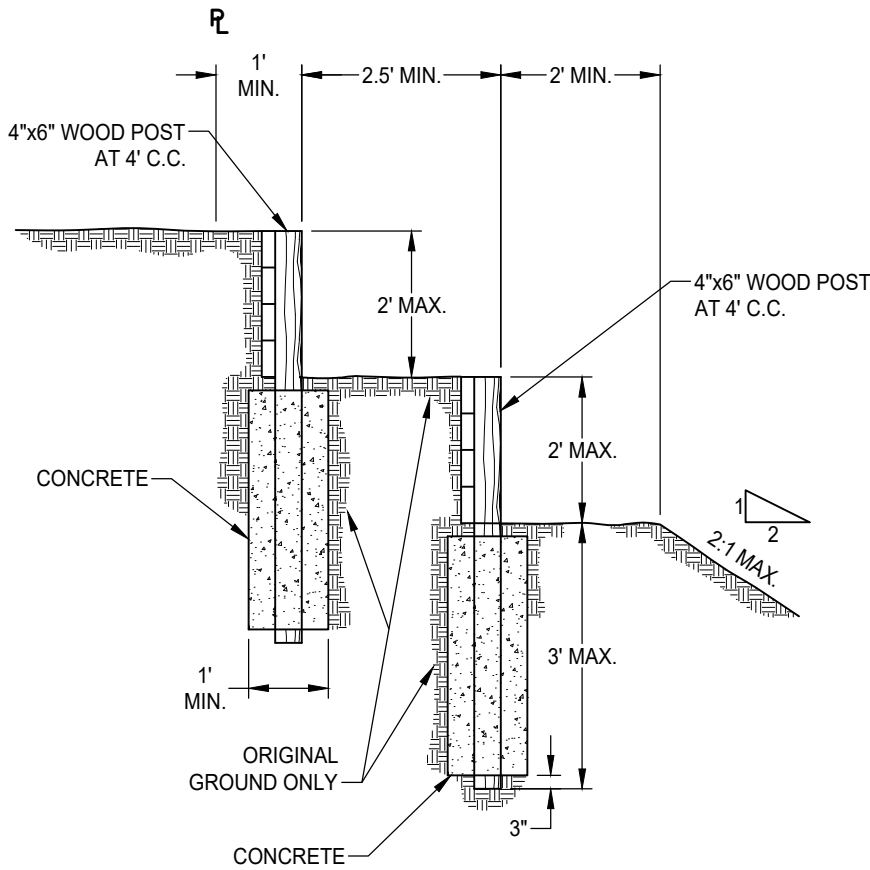

NOTES:

1. MATERIAL FOR WALLS SHALL BE GRADE NO. 2 OR BETTER REDWOOD WITH NO OPEN GRAIN MATERIAL.
2. WOOD WALLS SHALL NOT BE USED ADJACENT TO PUBLIC RIGHTS OF WAY.
3. ALL WALLS WITHIN 8 FEET OF A BOUNDARY OR PROJECT PHASE LINE SHALL BE CONSTRUCTED WITH MASONRY OR CONCRETE.
4. 4-INCH BY 6-INCH POSTS AT 4-FOOT ON CENTER SHALL BE USED AS FENCE POSTS WHEN FENCES ARE ATTACHED TO RETAINING WALLS.
5. NO DOUBLE RETAINING WALLS SHALL BE CONSTRUCTED ON SIDE YARDS.

DATE: 09/22/2017		NOT TO SCALE	
REVISION	BY	APPROVED	DATE

CITY OF ELK GROVE - PUBLIC WORKS

**WOOD RETAINING WALL DETAILS
FOR INTERIOR PROPERTY LINES**

APPROVED BY:
Paul Murbach
CITY ENGINEER

10/24/2018
DATE

DRAWING NUMBER
G - 3



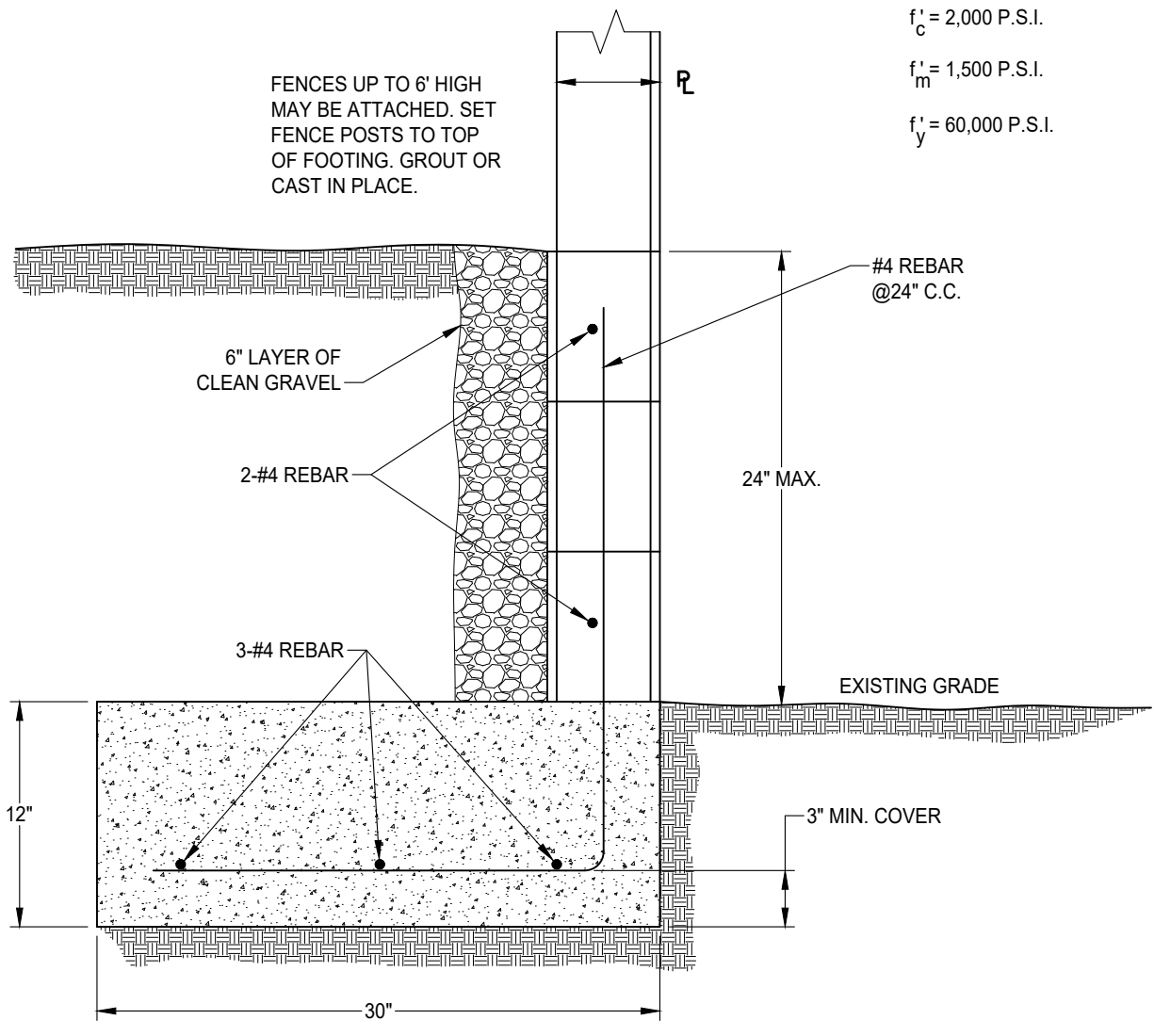

NOTES:

1. 8-INCH NORMAL WEIGHT BLOCK WITH FULL GROUTING REQUIRED.
2. A 6-INCH WIDE CAST-IN-PLACE CONCRETE STEM WALL MAY BE USED IN LIEU OF MASONRY.
3. SPECIAL INSPECTION IS NOT REQUIRED.
4. A BUILDING PERMIT IS REQUIRED FOR WALLS EXCEEDING 24" IN HEIGHT WHEN CONSTRUCTION DETAILS ARE NOT SHOWN ON APPROVED IMPROVEMENT PLANS.

DATE: 09/22/2017		NOT TO SCALE	
REVISION	BY	APPROVED	DATE

CITY OF ELK GROVE - PUBLIC WORKS

**MASONRY/CONCRETE RETAINING WALL
DETAIL FOR FILL AREAS AT BOUNDARY
AND PROJECT PHASE LINES**

APPROVED BY:
Paul Murbach
CITY ENGINEER

10/24/2018
DATE

DRAWING NUMBER
G - 4



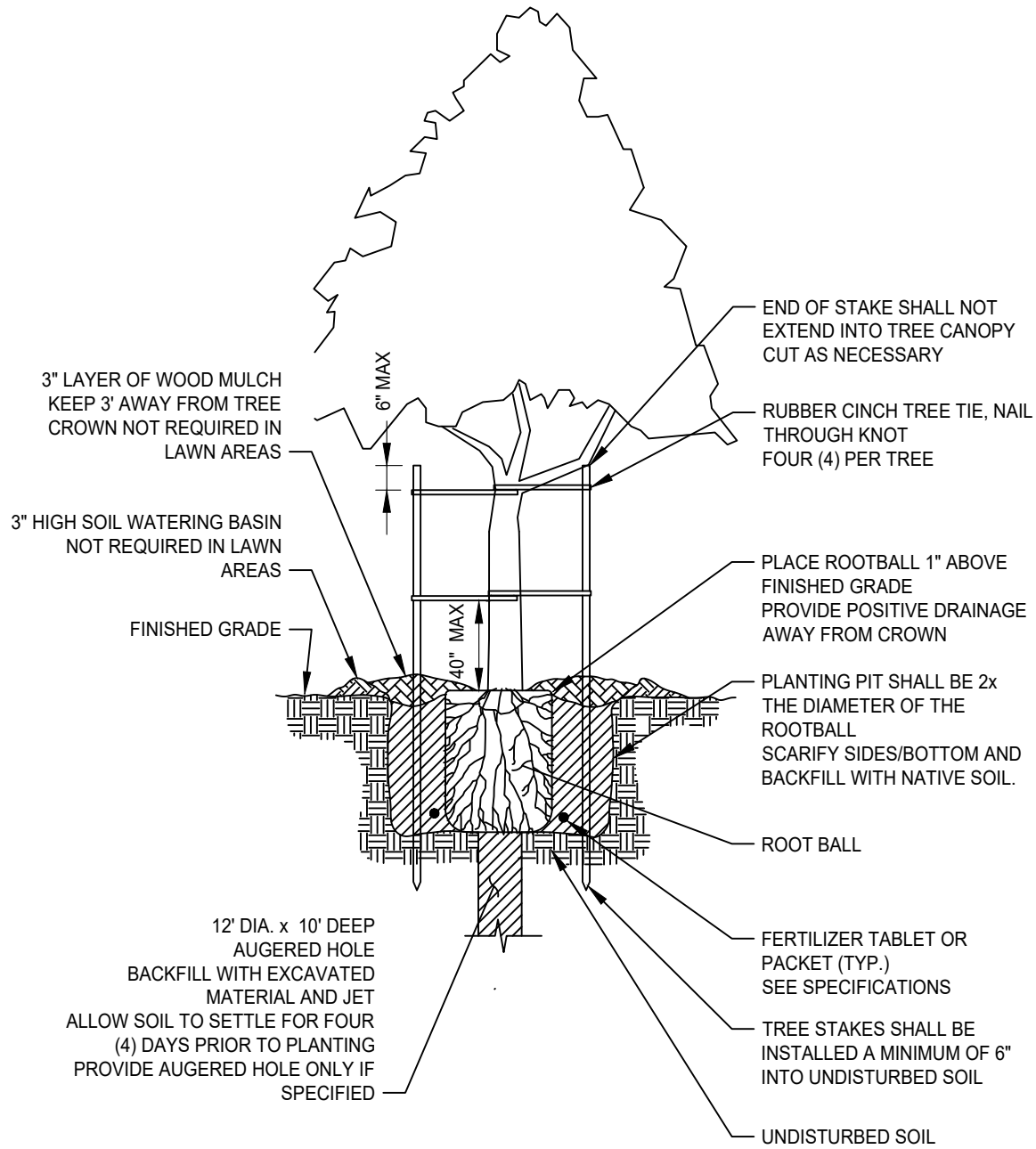

NOTE:

1. FOR 36" BOX TREES. STAGE WITH TWO 2" X 12' LONG SCHEDULE 40 GALVANIZED STEEL PIPES. PAINTED WITH TWO COATS OF DARK GREEN PAINT. TIE TREE WITH A METAL TWIST BRACE BOLTED TO THE STAKES OR OTHER APPROVED TREE TIE AS SPECIFIED.

DATE: 09/22/2017		NOT TO SCALE	
REVISION	BY	APPROVED	DATE

CITY OF ELK GROVE - PUBLIC WORKS

TREE PLANTING

APPROVED BY:
Paul Murbach
CITY ENGINEER

10/24/2018
DATE

DRAWING NUMBER
L - 1



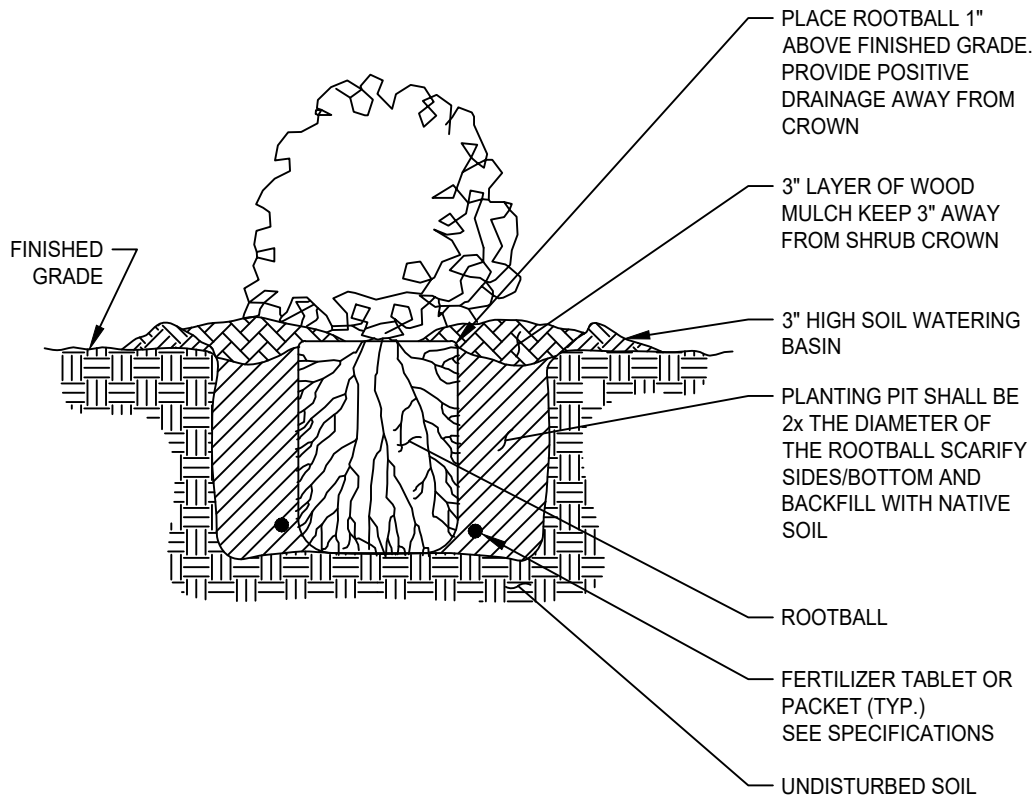

DATE: 09/22/2017		NOT TO SCALE	
REVISION	BY	APPROVED	DATE

CITY OF ELK GROVE - PUBLIC WORKS

SHRUB PLANTING

APPROVED BY:
Paul Murock
 CITY ENGINEER 10/24/2018
 DATE

DRAWING NUMBER
L - 2



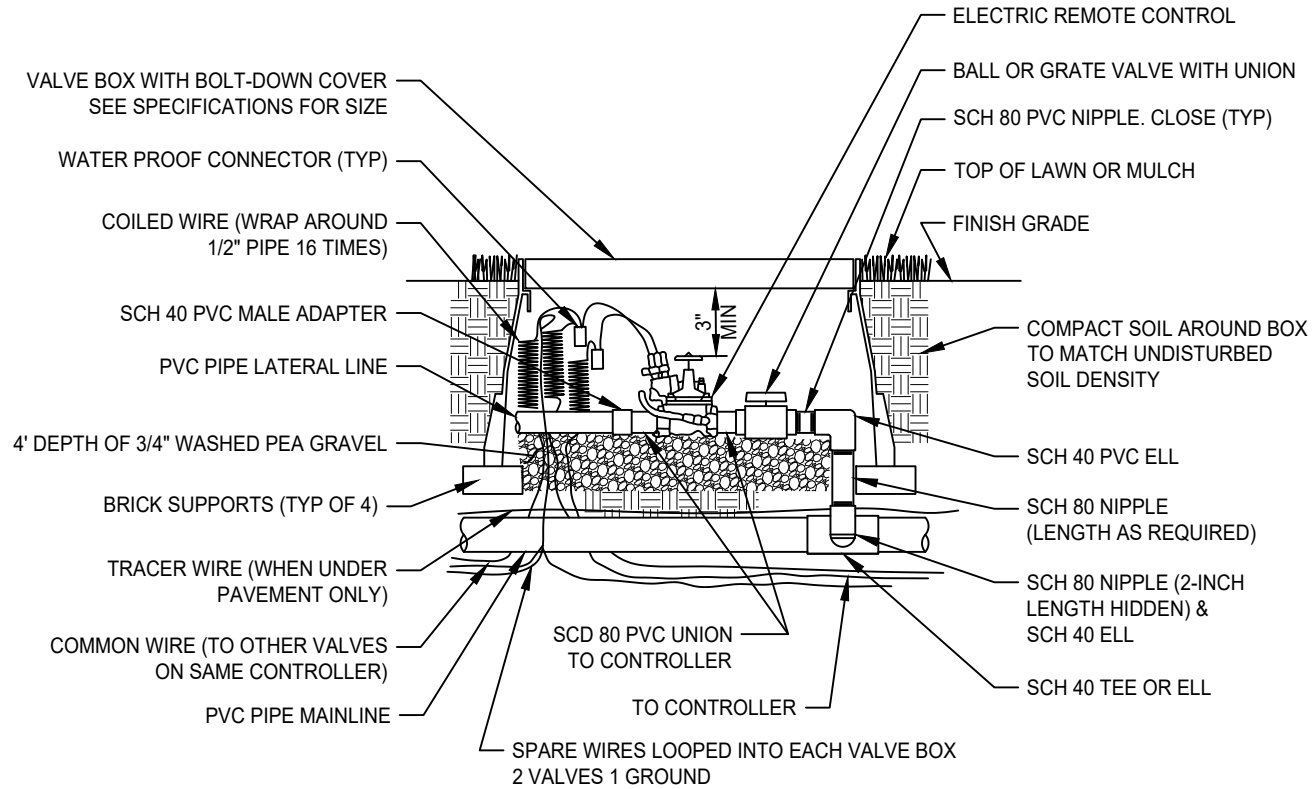

NOTES:

1. ALL WIRE SHALL BE TAPED AND BUNDLED EVERY TEN FEET AND SHALL BE INSTALLED AS PER LOCAL CODE.
2. SHUT-OFF VALVES 3" AND SMALLER SHALL BE SCH. 80 BALL VALVES. VALVES LARGER THAN 3" SHALL BE BRASS GATE VALVES.
3. ALL VALVE BOXES AND LIDS WITHIN THE SIDEWALK SHALL BE OF TRAFFIC RATED QUALITY.

DATE: 09/22/2007		NOT TO SCALE	
REVISION	BY	APPROVED	DATE

CITY OF ELK GROVE - PUBLIC WORKS

REMOTE CONTROL VALVE

APPROVED BY:

Paul M. Muelich

10/24/2018

CITY ENGINEER

DATE



DRAWING NUMBER

L - 3

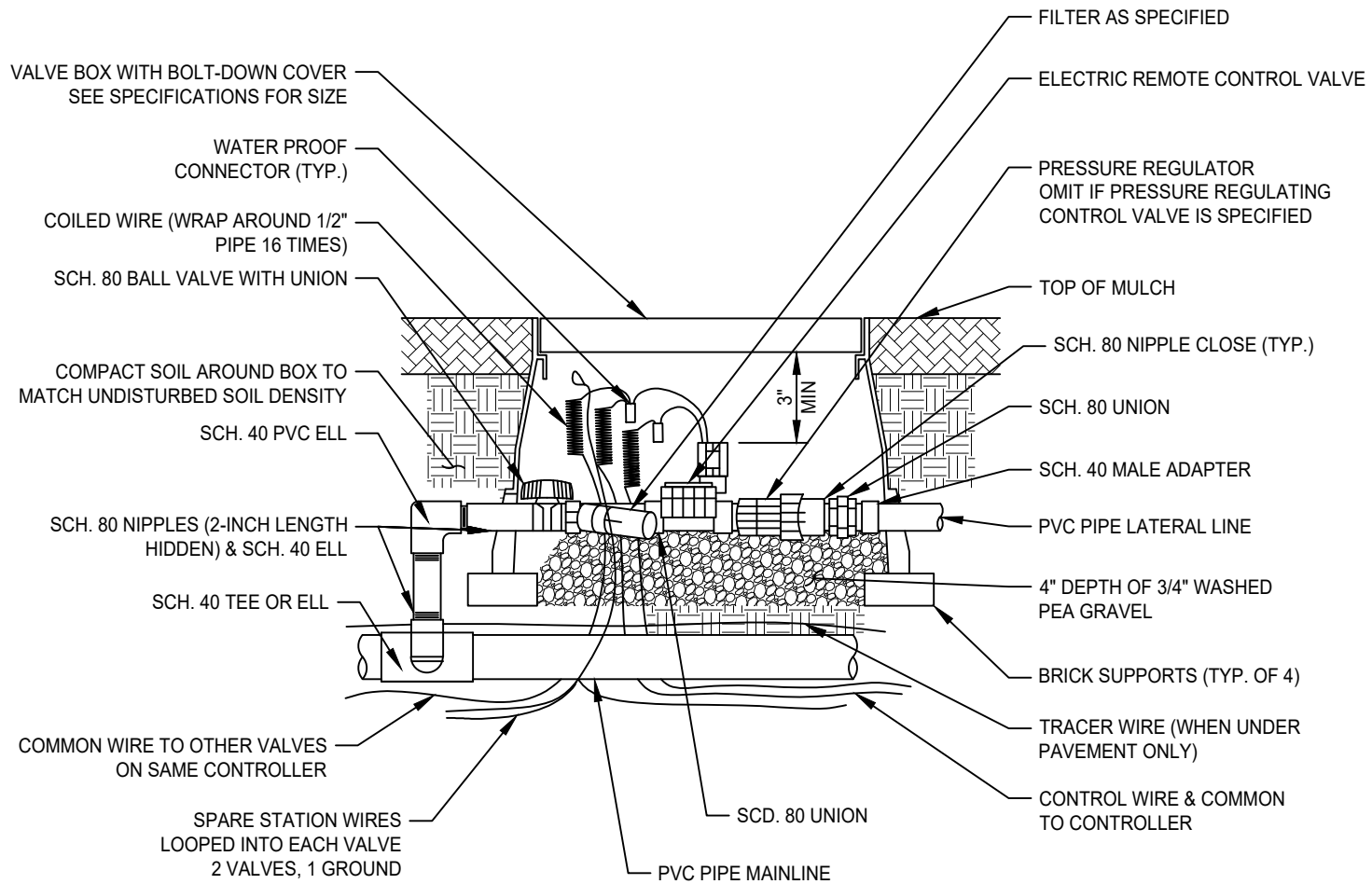

NOTES:

1. ALL WIRE SHALL BE TAPED AND BUNDLED EVERY TEN FEET AND SHALL BE INSTALLED AS PER LOCAL CODE.
2. ALL VALVE BOXES AND LIDS WITHIN THE SIDEWALK SHALL BE OF TRAFFIC RATED QUALITY.

DATE: 09/22/2007		NOT TO SCALE	
REVISION	BY	APPROVED	DATE

CITY OF ELK GROVE - PUBLIC WORKS

**DRIP IRRIGATION
VALVE ASSEMBLY**

APPROVED BY:

Paul Murock

CITY ENGINEER

10/24/2018

DATE



DRAWING NUMBER

L - 4

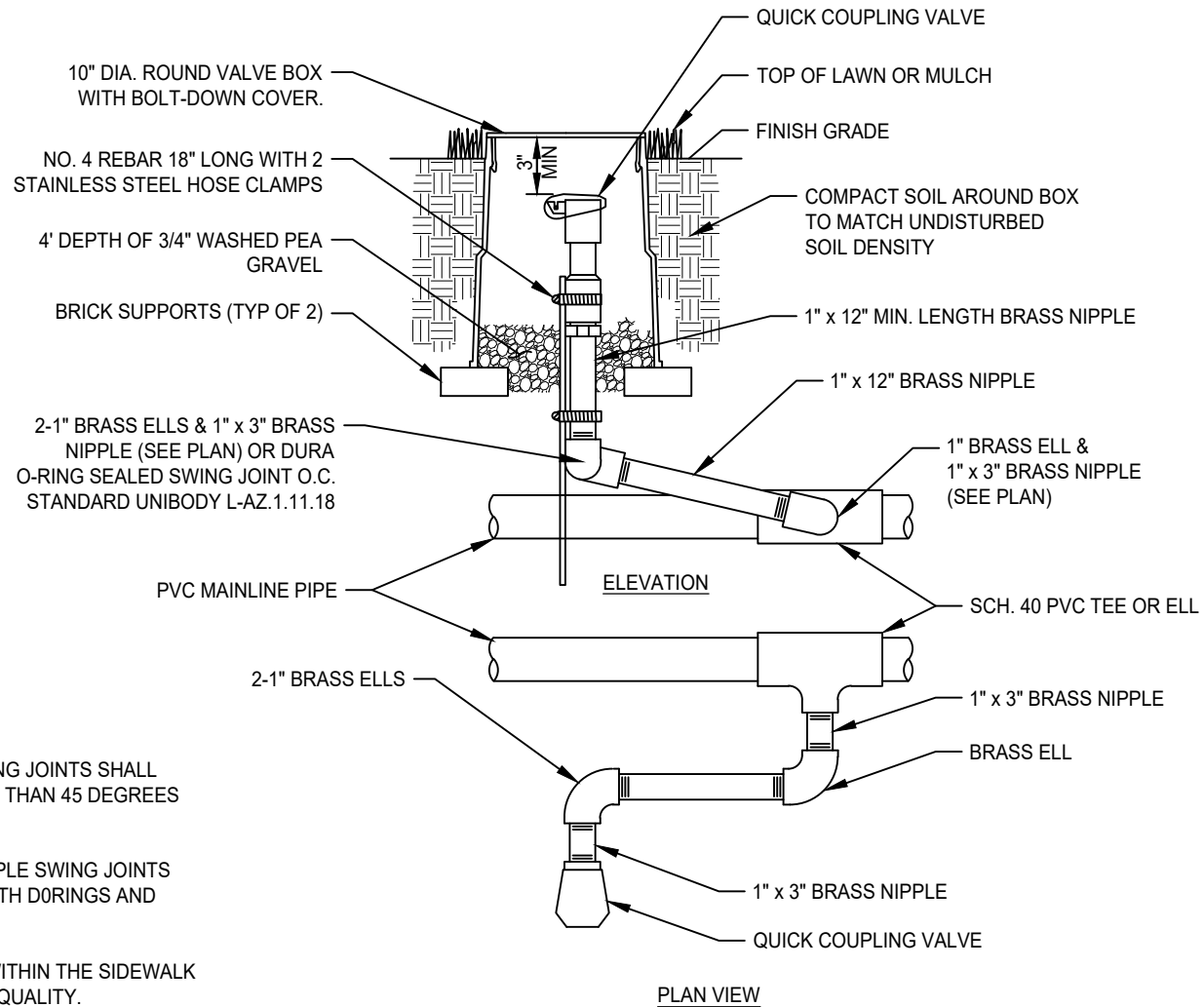

NOTES:

1. INSTALLATION OF TRIPLE SWING JOINTS SHALL BE AT AN ANGLE NO GREATER THAN 45 DEGREES TO HORIZONTAL
2. ALL PRE-MANUFACTURED TRIPLE SWING JOINTS SHALL BE MANUFACTURED WITH O-RINGS AND SHALL BE RATED AT 200 PSI.
3. ALL VALVE BOXES AND LIDS WITHIN THE SIDEWALK SHALL BE OF TRAFFIC RATED QUALITY.

DATE: 09/22/2007		NOT TO SCALE	
REVISION	BY	APPROVED	DATE

CITY OF ELK GROVE - PUBLIC WORKS

APPROVED BY:

Paul M. Mudgett

10/24/2018

CITY ENGINEER

DATE

QUICK COUPLING VALVE



DRAWING NUMBER

L - 5

PIPE SIZING CHART		
FLOW METER SIZE	UPSTREAM LENGTH	DOWNSTREAM LENGTH
1"	10"	5"
1.25"	12.5"	6.25"
1.5"	15"	7.5"
2"	20"	10"
3"	30"	15"

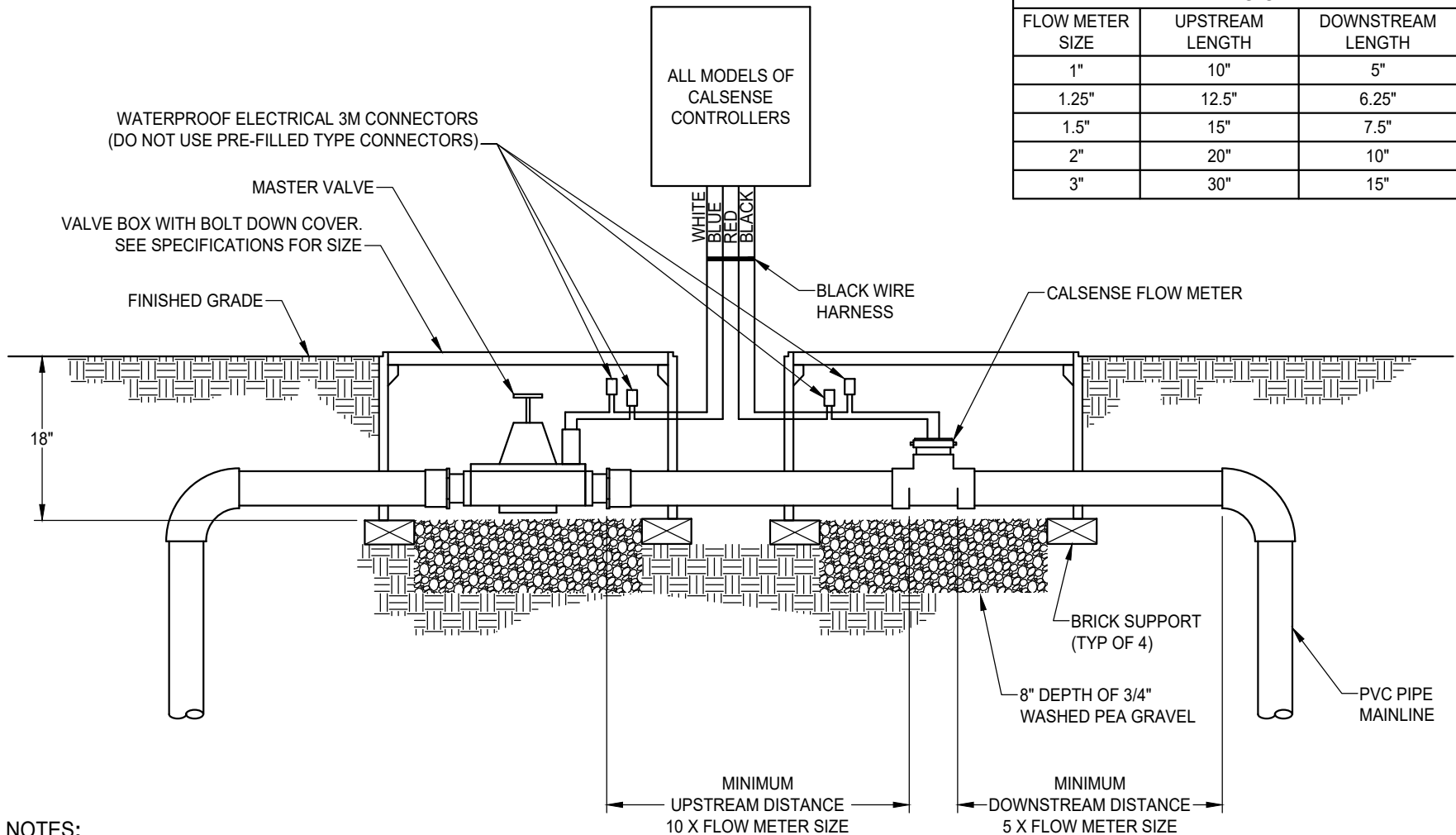

NOTES:

1. ALL VALVE BOXES AND LIDS WITHIN THE SIDEWALK AREA SHALL BE TRAFFIC RATED QUALITY.

DATE: 09/22/2007		NOT TO SCALE	
REVISION	BY	APPROVED	DATE

CITY OF ELK GROVE - PUBLIC WORKS

**MASTER VALVE
FLOW SENSOR**

APPROVED BY:
Paul Murock
CITY ENGINEER

10/24/2018
DATE

DRAWING NUMBER
L - 6



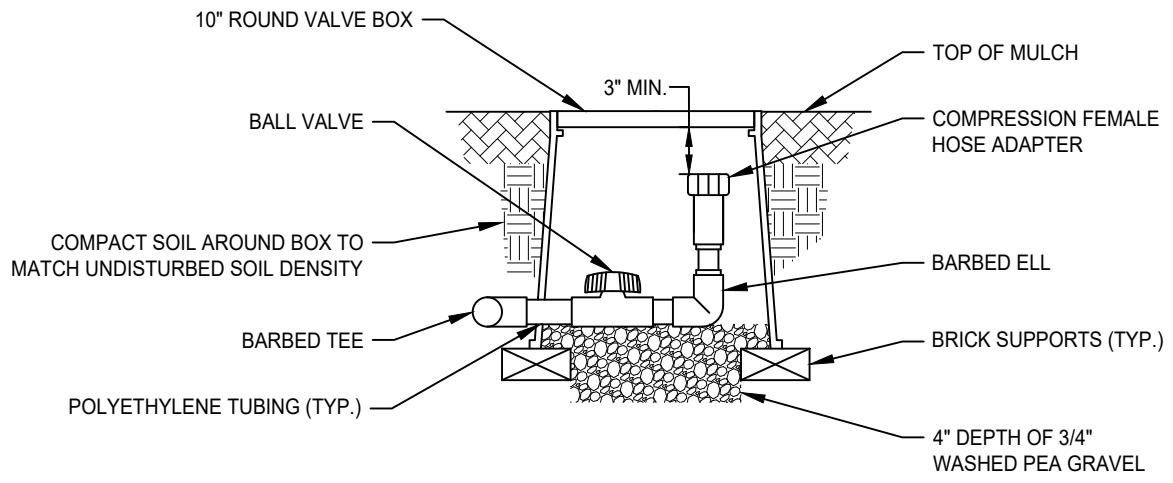

NOTES:

1. ALL VALVE BOXES AND LIDS WITHIN THE SIDEWALK AREA SHALL BE OF TRAFFIC RATED QUALITY.

DATE: 09/22/2007		NOT TO SCALE	
REVISION	BY	APPROVED	DATE

CITY OF ELK GROVE - PUBLIC WORKS

FLUSH VALVE

APPROVED BY:

Paul Murock

CITY ENGINEER

10/24/2018

DATE



DRAWING NUMBER

L - 7

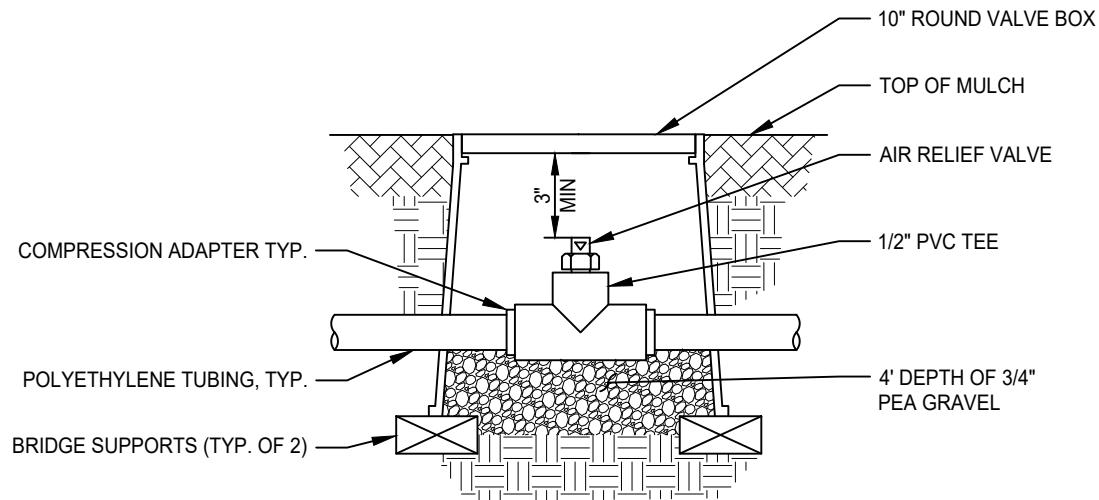

NOTES:

1. AIR RELIEF VALVE SHALL BE INSTALLED AT THE HIGHEST POINT OF THE SYSTEM ABOVE ALL DRIPLINE LATERALS.
2. ALL VALVE BOXES AND LIDS WITHIN THE SIDEWALK SHALL BE OF TRAFFIC RATED QUALITY.

DATE: 09/22/2007		NOT TO SCALE	
REVISION	BY	APPROVED	DATE

CITY OF ELK GROVE - PUBLIC WORKS

AIR RELIEF VALVE

APPROVED BY:

Paul Murock

CITY ENGINEER

10/24/2018

DATE



DRAWING NUMBER

L - 8

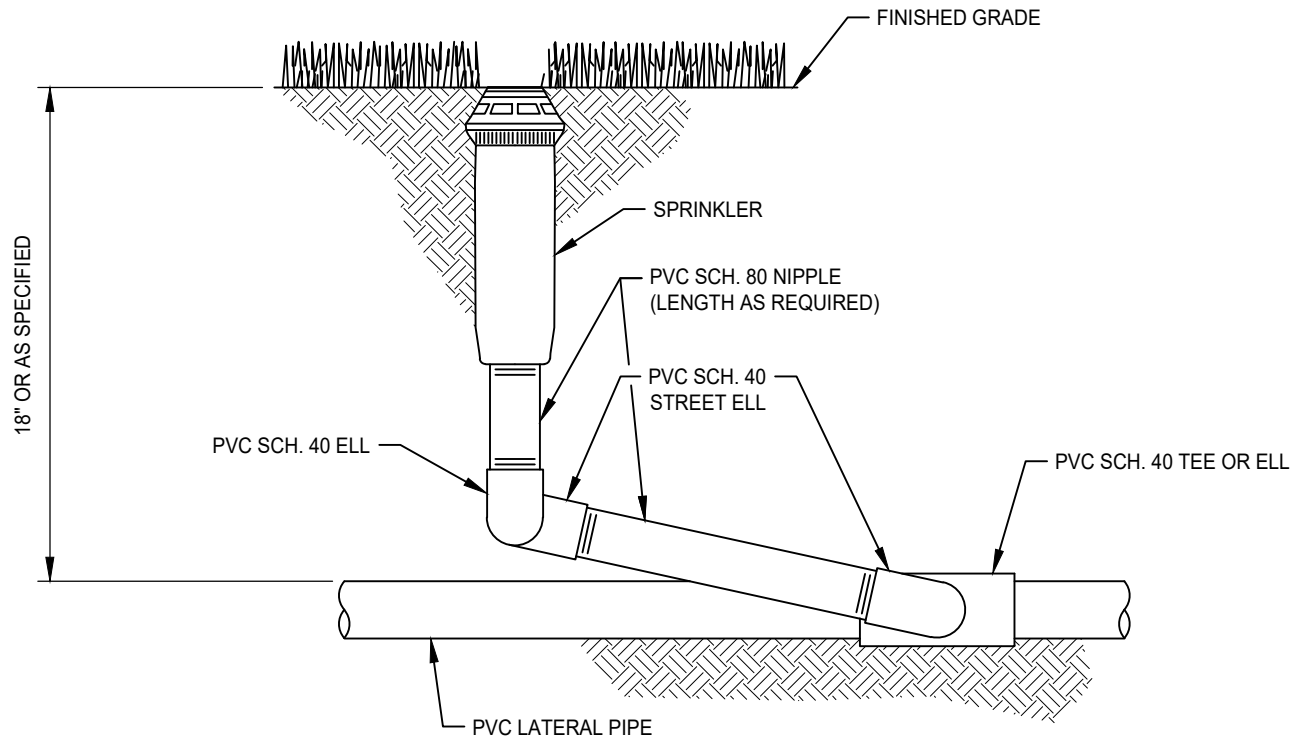

NOTES:

1. INSTALLATION OF TRIPLE SWING JOINTS SHALL BE AT AN ANGLE NO GREATER THAN 45 DEGREES TO HORIZONTAL.
2. ALL PRE-MANUFACTURED TRIPLE SWING JOINTS SHALL BE MANUFACTURED WITH O-RINGS AND SHALL BE RATED AT 200 PSI.

DATE: 09/22/2007		NOT TO SCALE	
REVISION	BY	APPROVED	DATE

CITY OF ELK GROVE - PUBLIC WORKS

POP-UP ROTOR SPRINKLER

APPROVED BY:

Paul Murock

CITY ENGINEER

10/24/2018

DATE



DRAWING NUMBER

L - 9

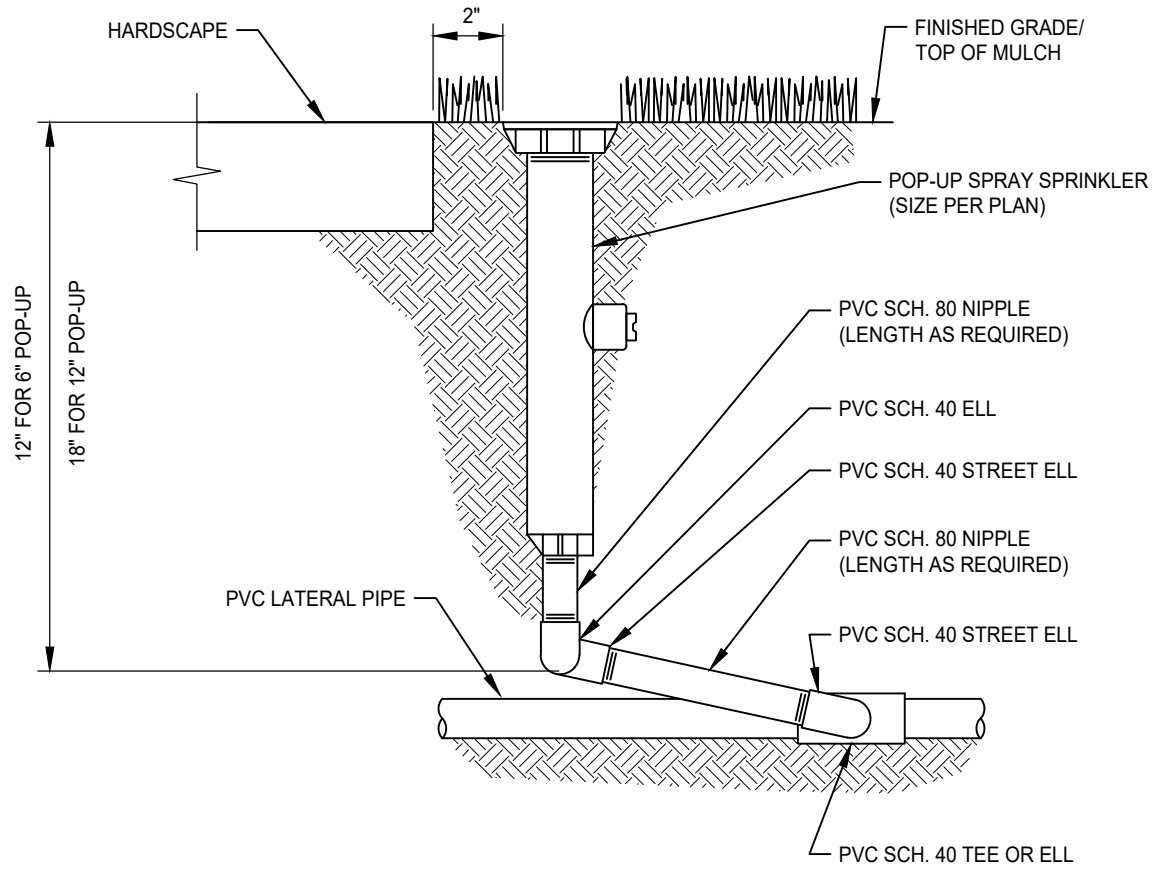

NOTES:

1. INSTALLATION OF TRIPLE SWING JOINTS SHALL BE AT AN ANGLE NO GREATER THAN 45 DEGREES TO HORIZONTAL.
2. ALL PRE-MANUFACTURED TRIPLE SWING JOINTS SHALL BE MANUFACTURED WITH O-RINGS AND SHALL BE RATED AT 200 PSI.

DATE: 09/22/2007		NOT TO SCALE	
REVISION	BY	APPROVED	DATE

CITY OF ELK GROVE - PUBLIC WORKS

POP-UP SPRAY SPRINKLER

APPROVED BY:

Paul Murock

CITY ENGINEER

10/24/2018

DATE



DRAWING NUMBER

L - 10

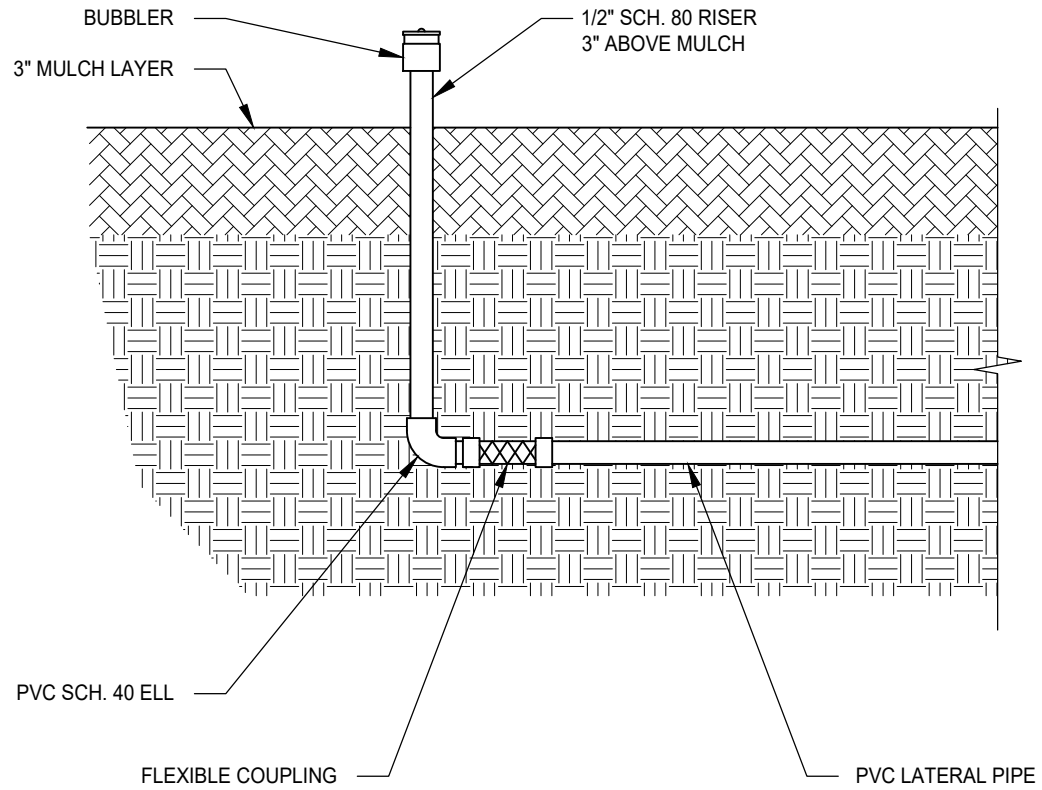

DATE: 09/22/2007		NOT TO SCALE	
REVISION	BY	APPROVED	DATE

CITY OF ELK GROVE - PUBLIC WORKS

BUBBLER SPRINKLER HEAD

APPROVED BY:
Paul Murock
 CITY ENGINEER

10/24/2018
 DATE

DRAWING NUMBER
L - 11



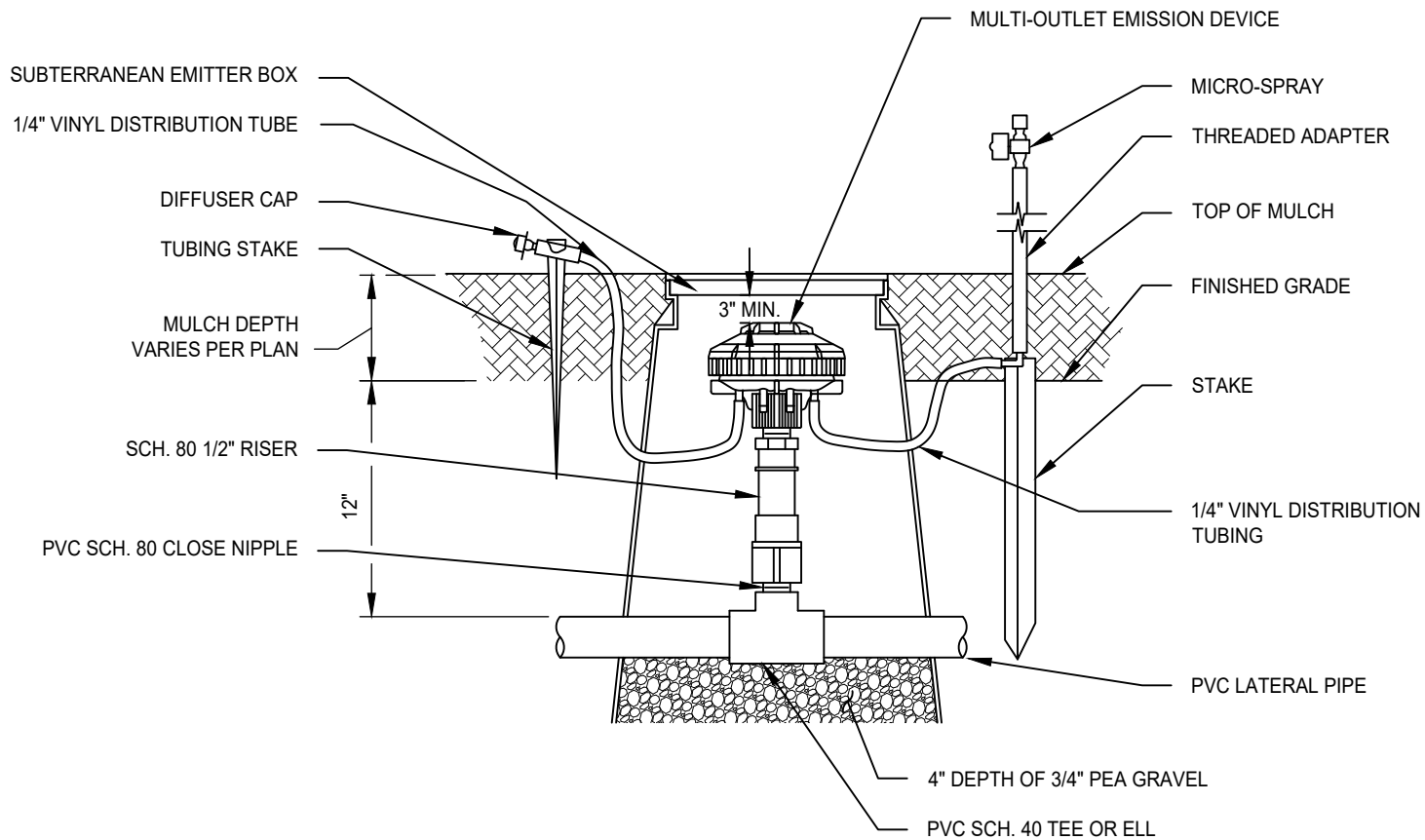

DATE: 09/22/2007		NOT TO SCALE	
REVISION	BY	APPROVED	DATE

CITY OF ELK GROVE - PUBLIC WORKS

**DRIP IRRIGATION
MULTI-OUTLET EMITTER**

APPROVED BY:
Paul Murock
CITY ENGINEER
10/24/2018
DATE



DRAWING NUMBER

L - 12

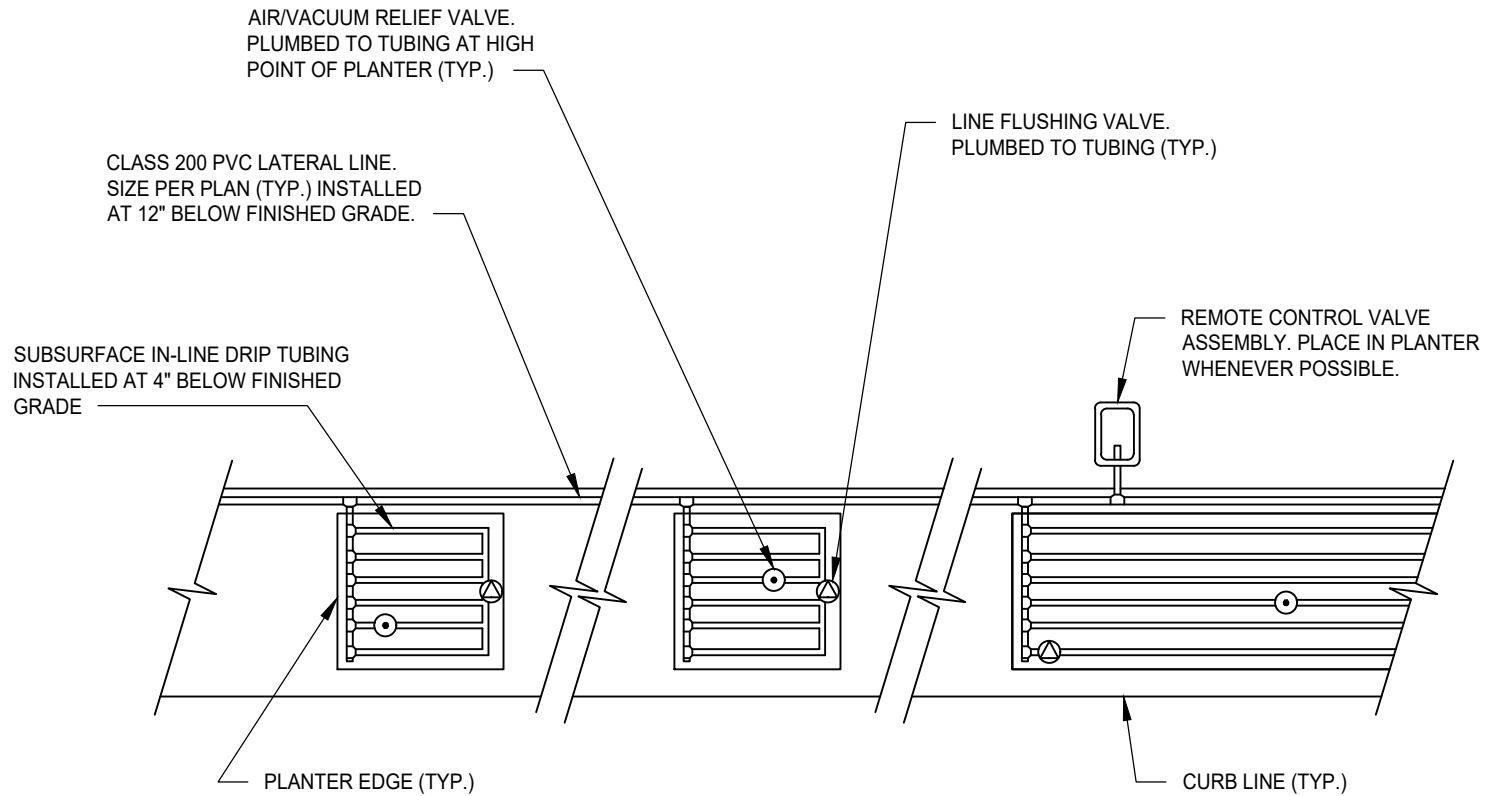

NOTES:

1. ALL DRIP TUBING FITTINGS SHALL BE BARBED.

DATE: 09/22/2007		NOT TO SCALE	
REVISION	BY	APPROVED	DATE

CITY OF ELK GROVE - PUBLIC WORKS

**SUBSURFACE IN-LINE
DRIP IRRIGATION LAYOUT**

APPROVED BY:

Paul Murock

CITY ENGINEER

10/24/2018

DATE



DRAWING NUMBER

L - 13

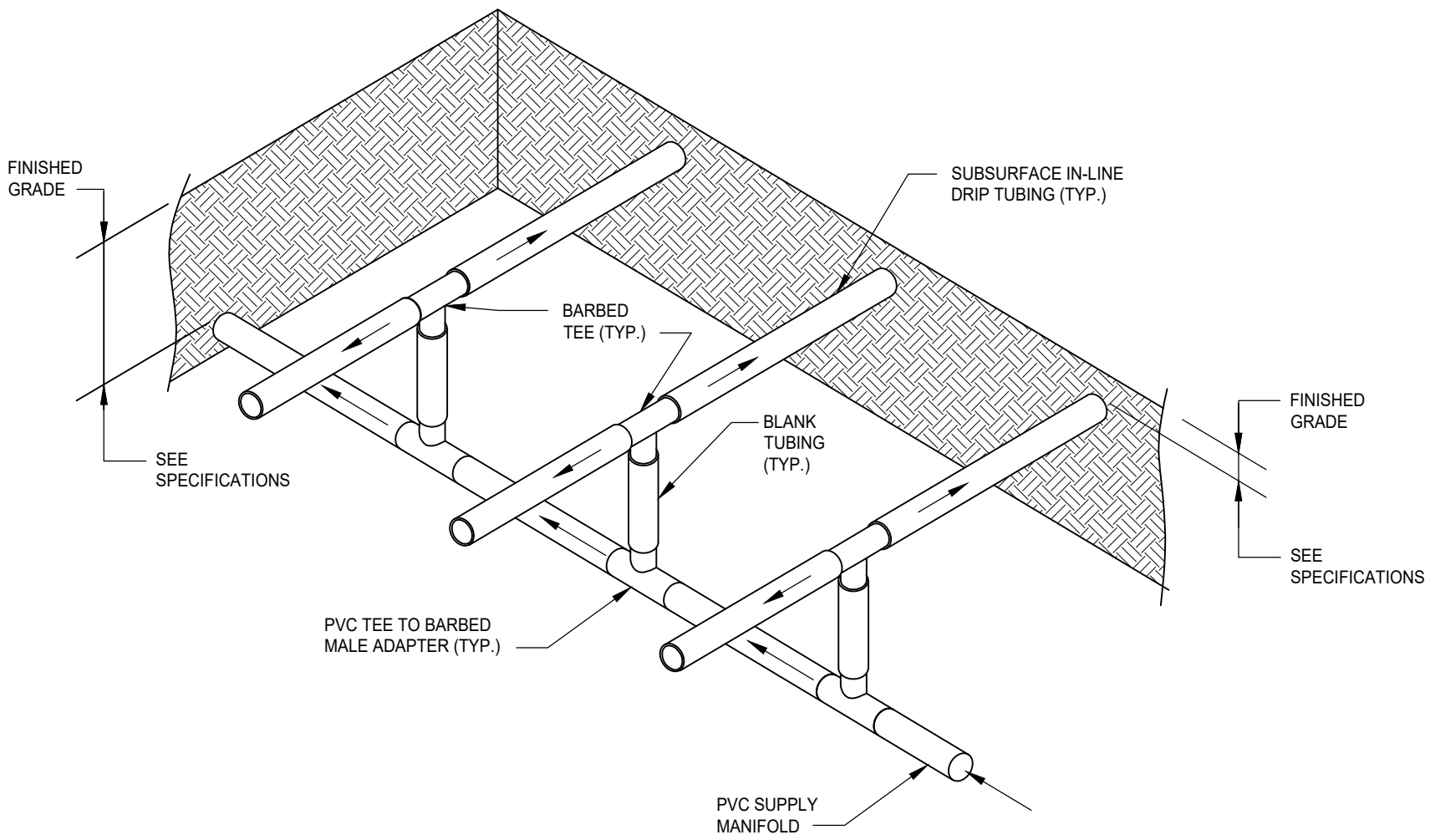

DATE: 09/22/2007		NOT TO SCALE	
REVISION	BY	APPROVED	DATE

CITY OF ELK GROVE - PUBLIC WORKS

**SUBSURFACE IN-LINE DRIP
IRRIGATION CENTER-FEED
SUPPLY MANIFOLD**

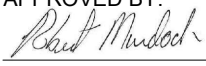
APPROVED BY:

 CITY ENGINEER 10/24/2018 DATE

DRAWING NUMBER
L - 14

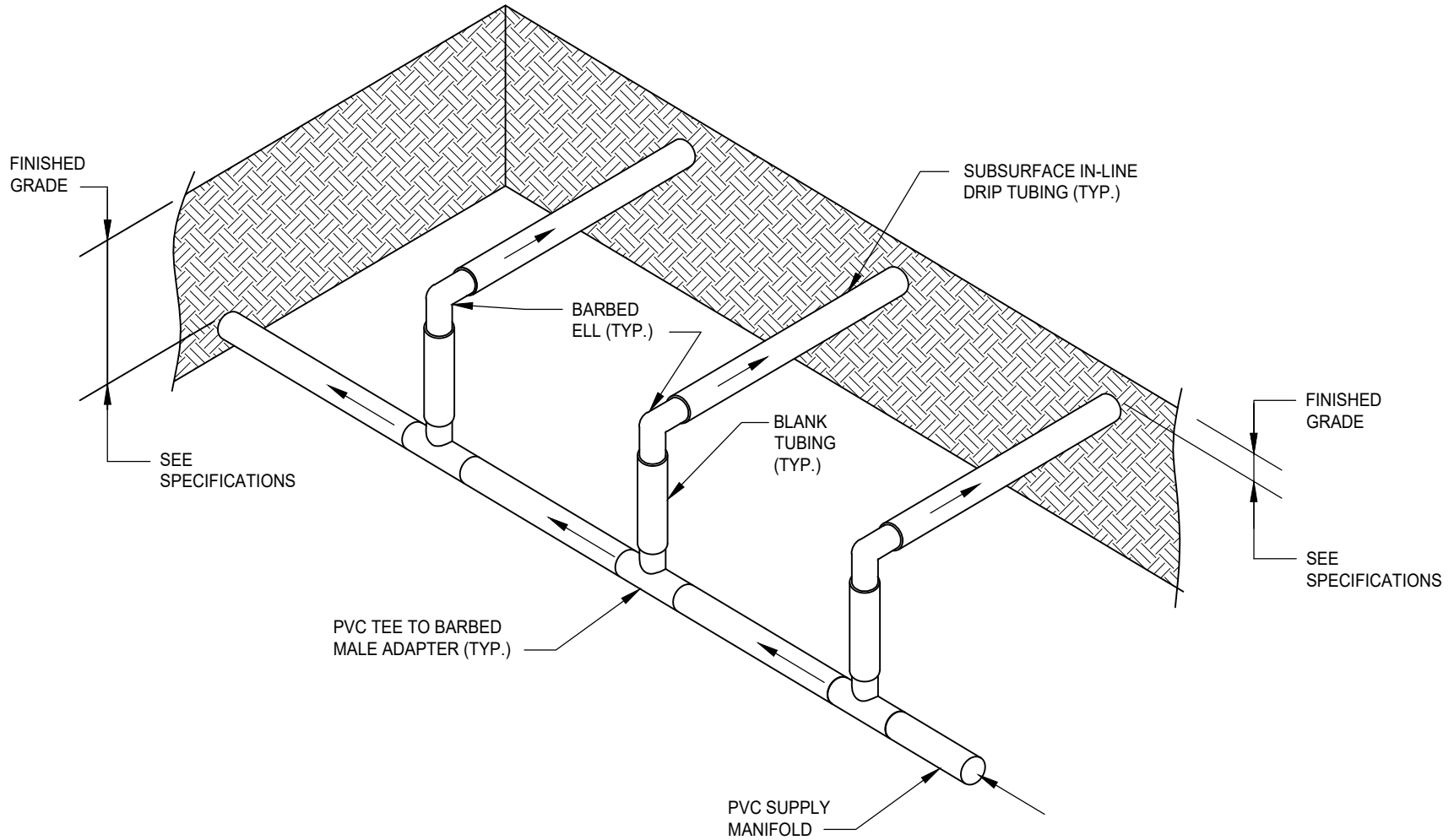





DATE: 09/22/2007		NOT TO SCALE	
REVISION	BY	APPROVED	DATE

CITY OF ELK GROVE - PUBLIC WORKS

**SUBSURFACE IN-LINE DRIP
IRRIGATION END-FEED
SUPPLY MANIFOLD**

APPROVED BY:

 CITY ENGINEER 10/24/2018 DATE

DRAWING NUMBER
L - 15

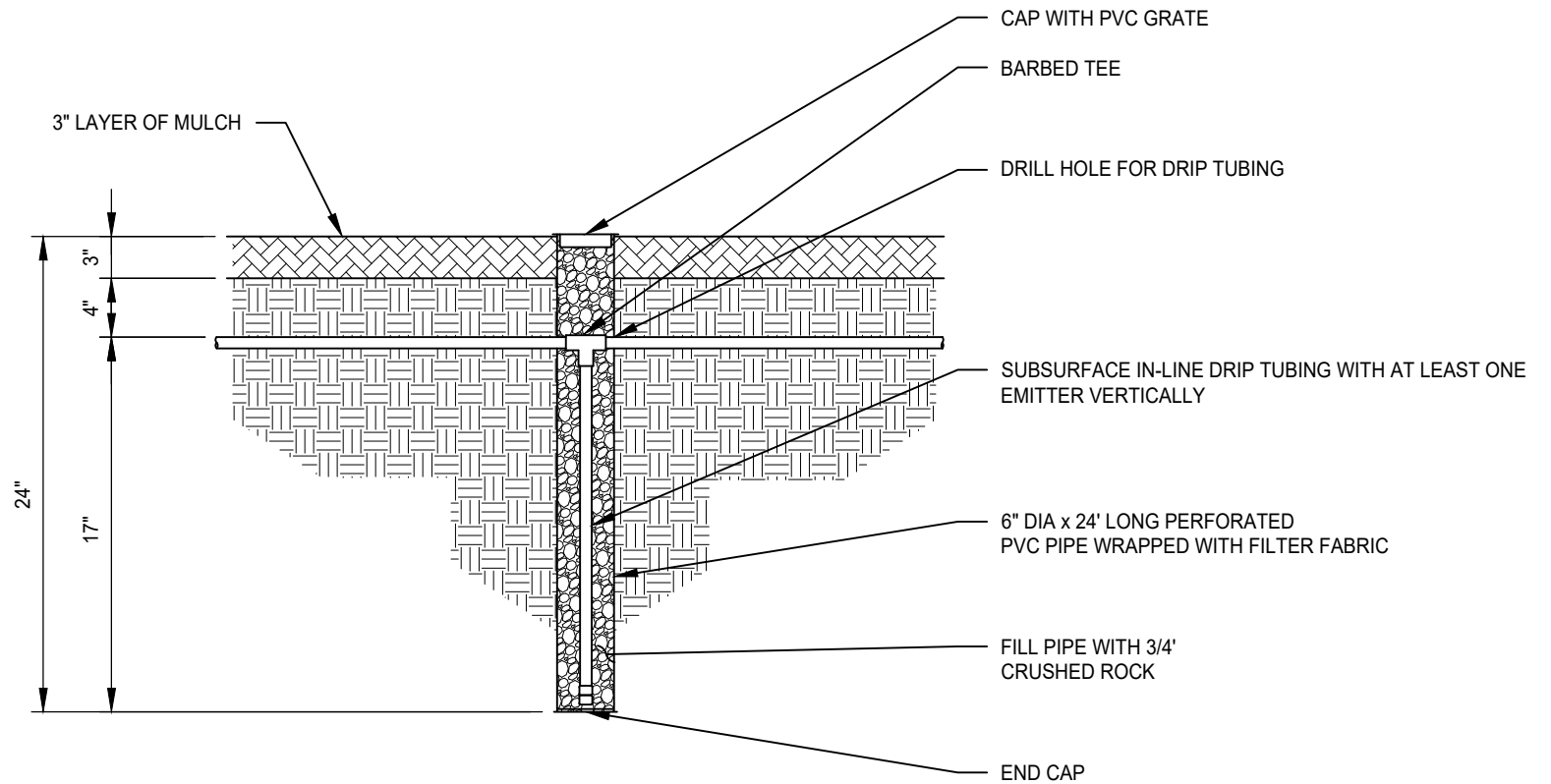



DATE: 09/22/2007		NOT TO SCALE	
REVISION	BY	APPROVED	DATE

CITY OF ELK GROVE - PUBLIC WORKS

**DEEP WATERING PIPE
FOR TREES**

APPROVED BY:

Paul Murock

CITY ENGINEER

10/24/2018

DATE



DRAWING NUMBER

L - 16

OPTIONAL DOME ANTENNA
 MODEL ANT-1 (DIGITAL RADIO)
 MODEL ANT-1-RR (DIGITAL RADION AND RR RADIO REMOTE OPTION)
 MODEL LR-DOME (LOCAL RADIO)
 MODEL LR-DOME-RR (LOCAL RADIO AND RR RADIO REMOTE OPTION)
 MODEL RR-DOME (RADIO REMOTE OPTION)

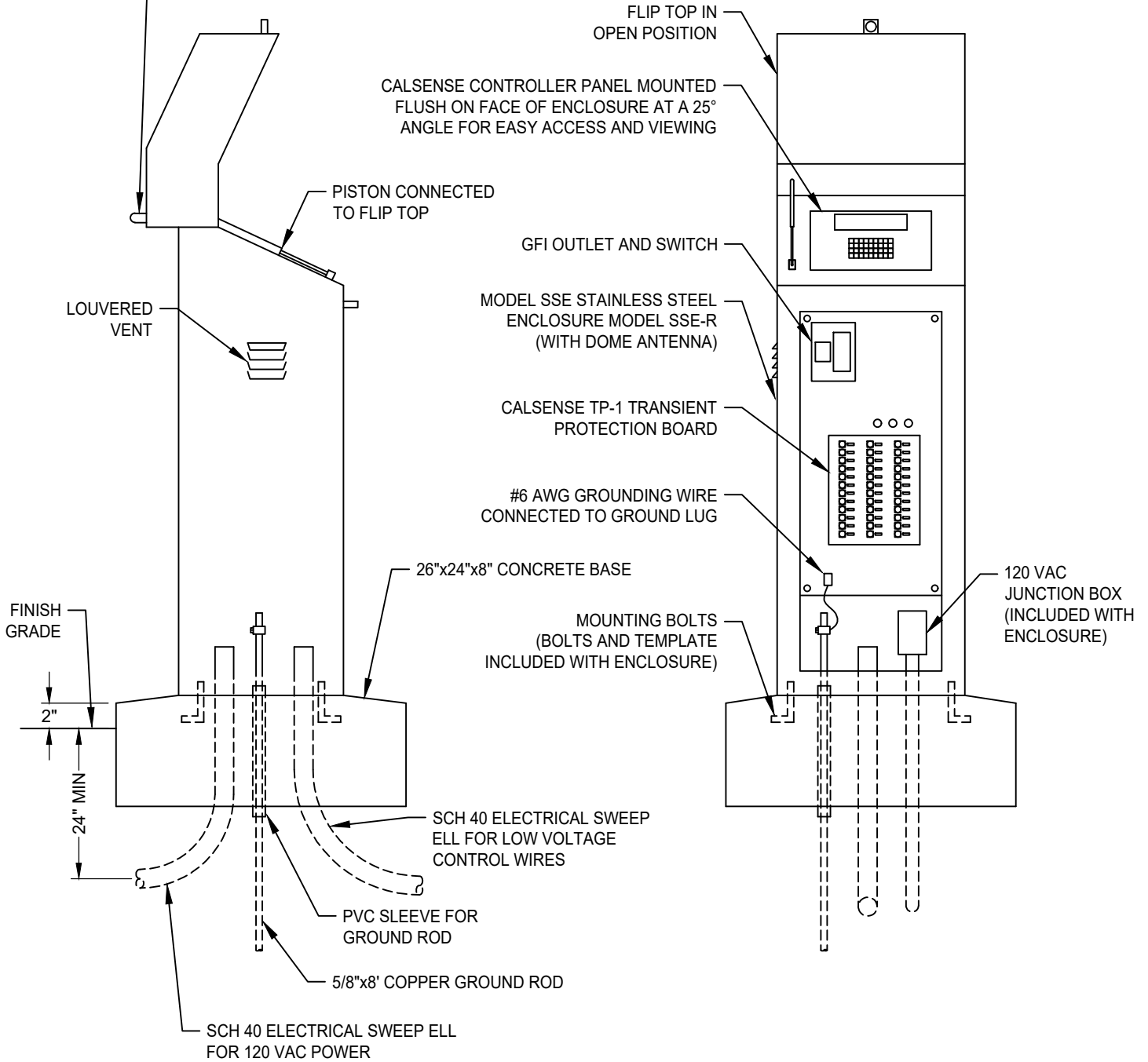

DATE: 09/22/2017		NOT TO SCALE	
REVISION	BY	APPROVED	DATE

CITY OF ELK GROVE - PUBLIC WORKS

IRRIGATION CONTROLLER ENCLOSURE

APPROVED BY:
Paul Murock
 CITY ENGINEER

10/24/2018
 DATE

DRAWING NUMBER
L - 17



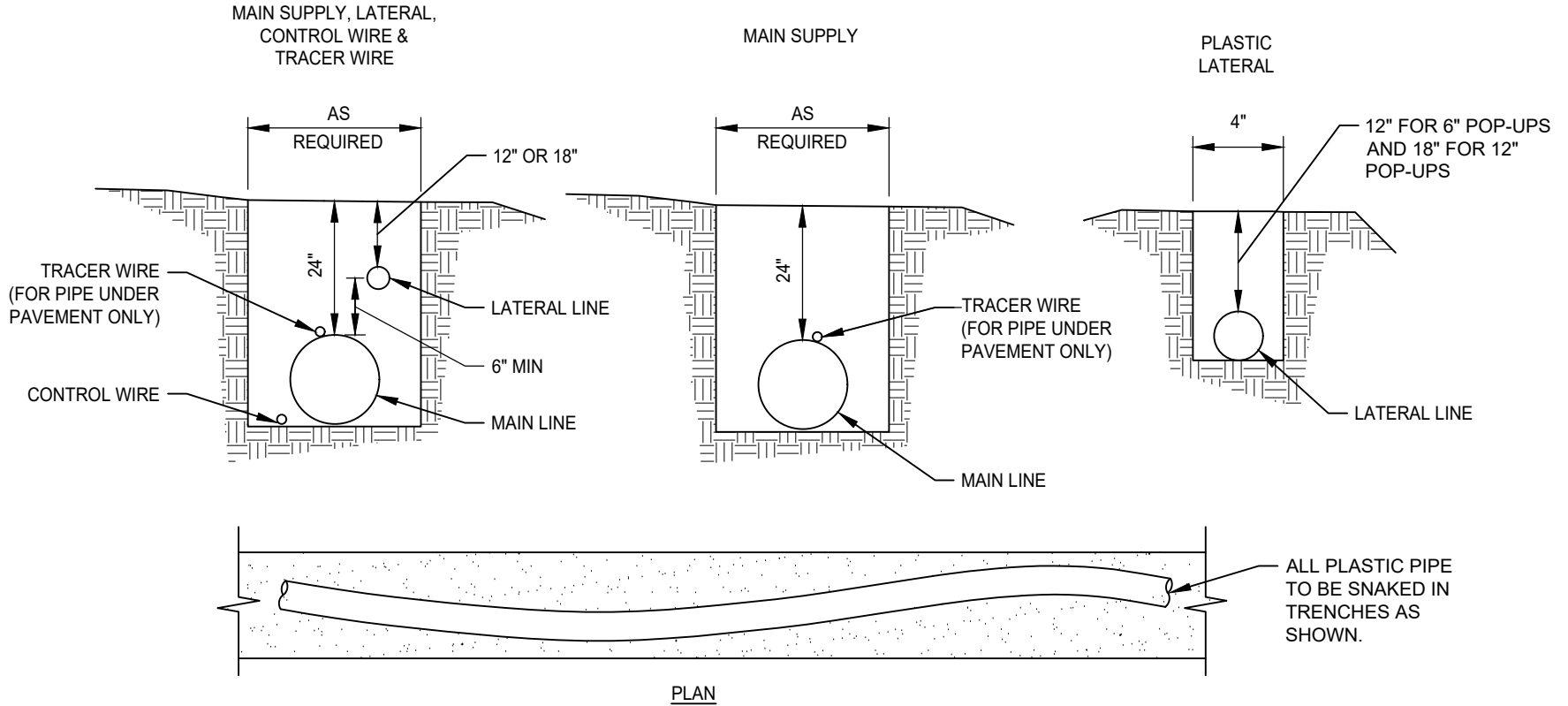

NOTES:

1. ALL TRENCH DEPTHS ARE MEASURED FROM TOP OF FINISH GRADE.
2. TRACER WIRE SHALL BE REQUIRED ONLY WHEN PIPES ARE INSTALLED UNDER PAVEMENT.
3. ALL PIPE TO BE INSTALLED IN ACCORDANCE WITH MANUFACTURERS INSTALLATION SPECIFICATIONS.
4. IF SPRINKLER HEAD AND NIPPLE HEIGHT EXCEED 11" LATERAL LINE DEPTH SHALL BE 18".
5. INSTALL PIPE BEDDING UNDER PIPING, WHEN SPECIFIED.
6. INSTALL SLEEVING UNDER PAVING PER PLANS.

DATE: 09/22/2007		NOT TO SCALE	
REVISION	BY	APPROVED	DATE

CITY OF ELK GROVE - PUBLIC WORKS

**IRRIGATION SYSTEM
TRENCHING**

APPROVED BY:

Paul Murock

CITY ENGINEER

10/24/2018

DATE



DRAWING NUMBER

L - 18

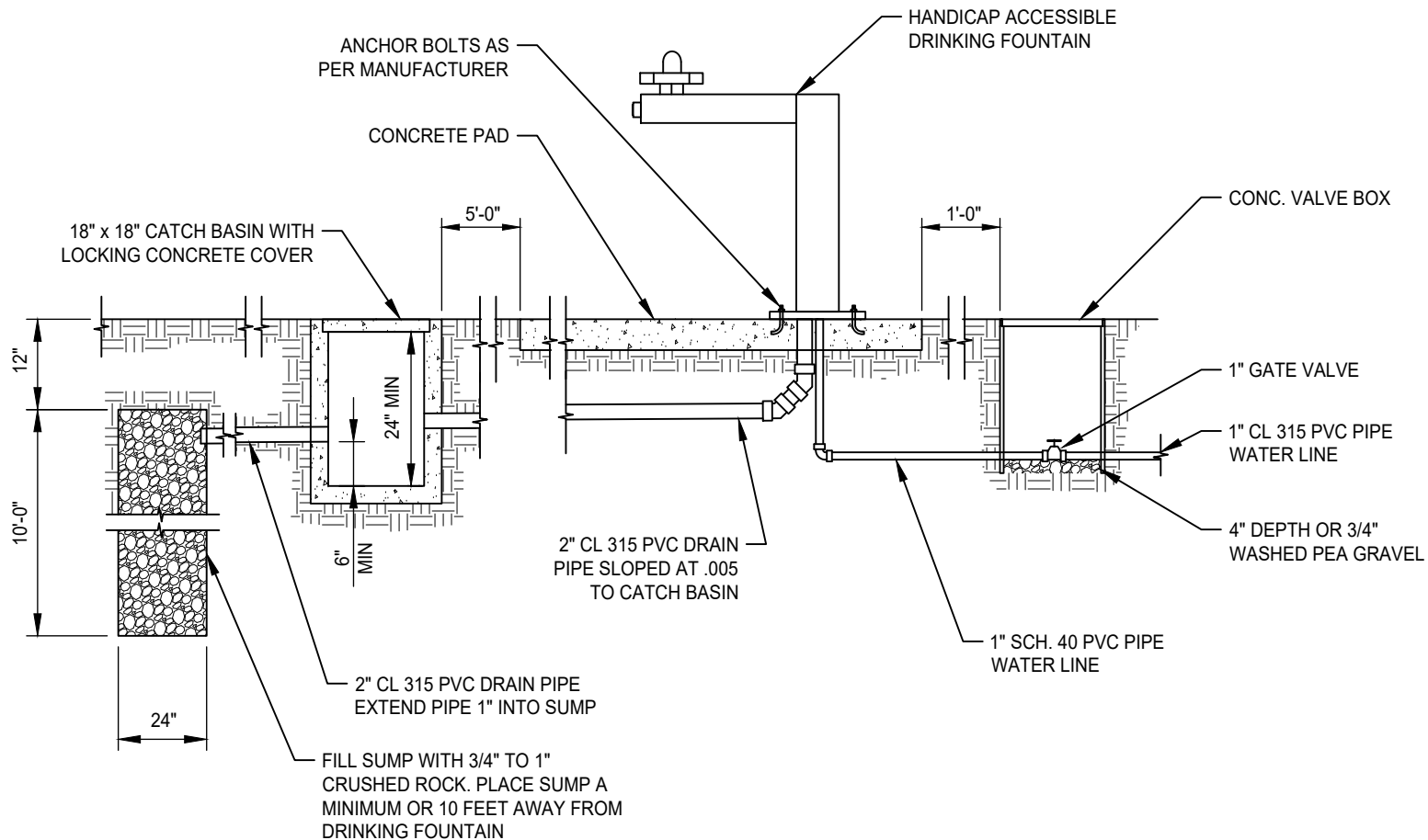

DATE: 09/22/2007		NOT TO SCALE	
REVISION	BY	APPROVED	DATE

CITY OF ELK GROVE - PUBLIC WORKS

DRINKING FOUNTAIN

APPROVED BY:
Paul Murock
 CITY ENGINEER

10/24/2018
 DATE

DRAWING NUMBER
L - 19



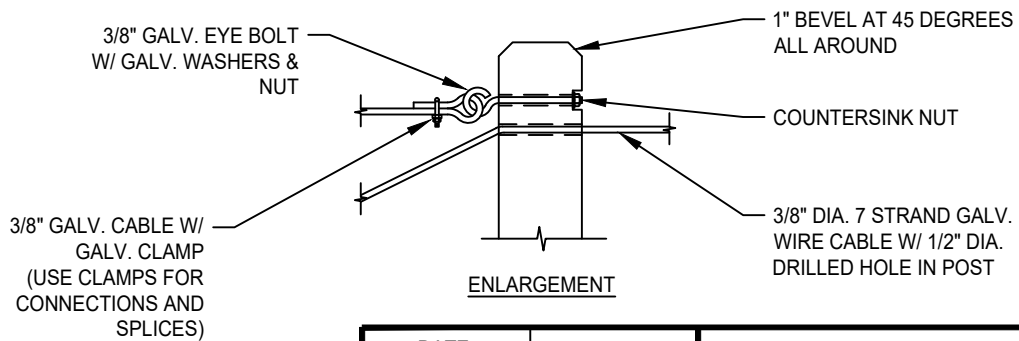
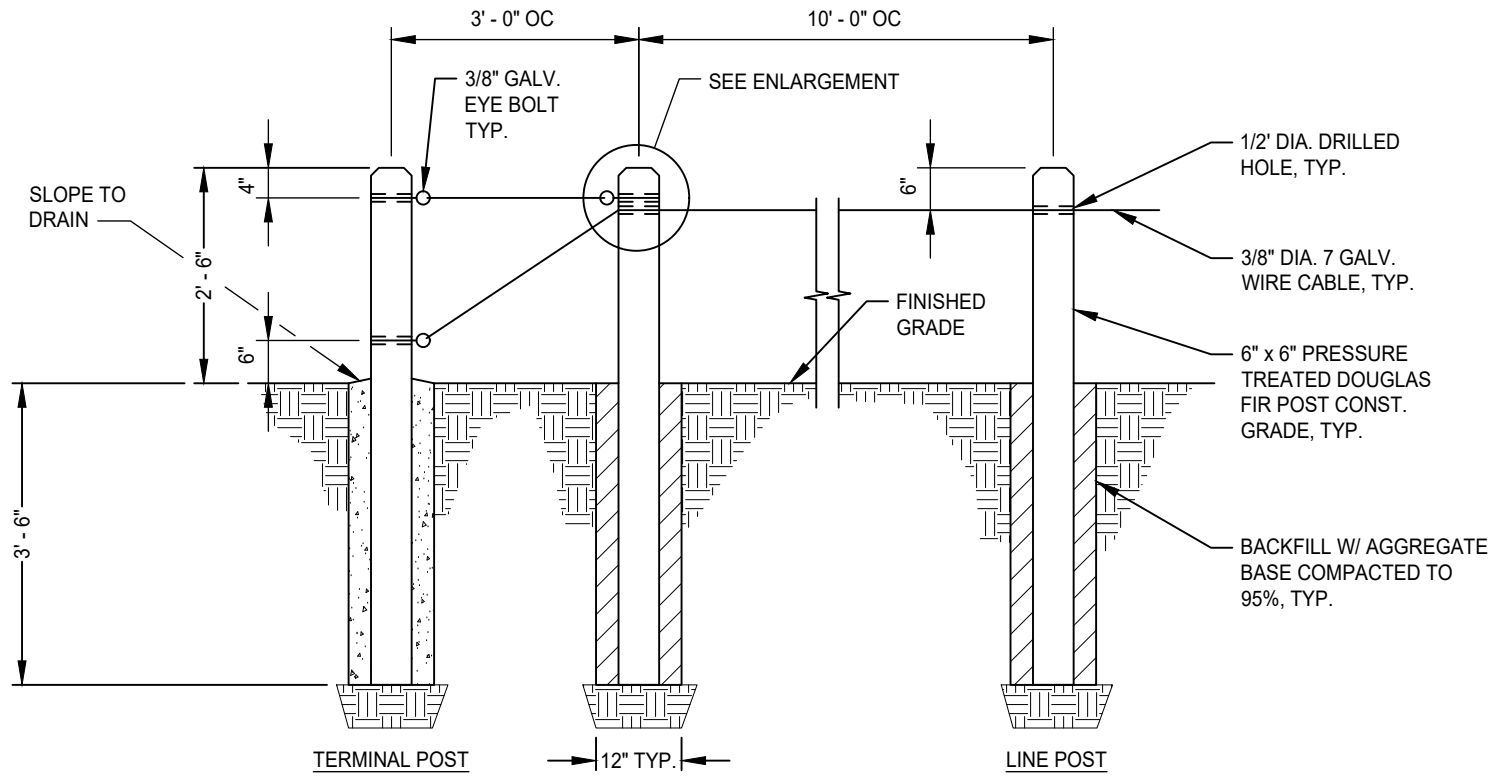

NOTES:

1. CONCRETE FOOTING SHALL BE INSTALLED AT ALL TERMINAL POSTS AND AT ALL BENDS.

DATE: 09/22/2007		NOT TO SCALE	
REVISION	BY	APPROVED	DATE
1	SJB	SMA	06-18-2025

CITY OF ELK GROVE - PUBLIC WORKS

POST AND CABLE FENCING

APPROVED BY: _____
06-20-2025
 DATE

CITY ENGINEER _____
 DATE

DRAWING NUMBER
L - 20



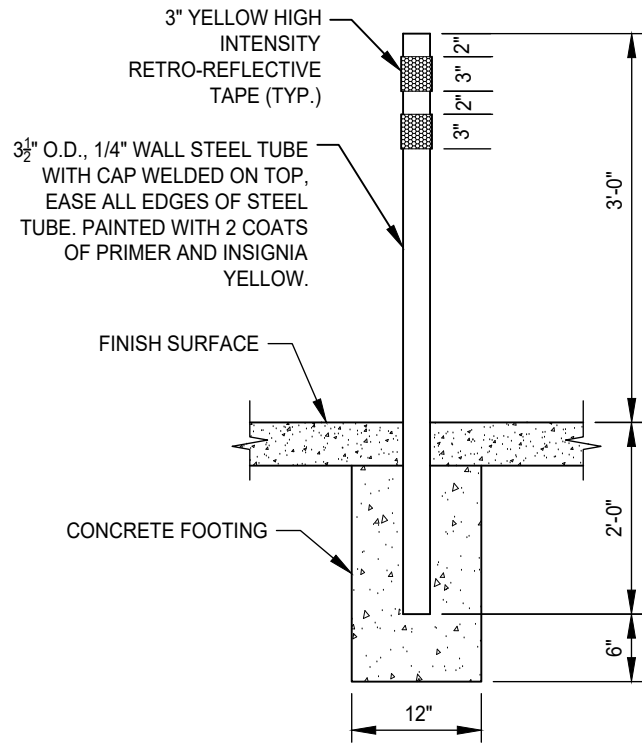

STATIONARY BOLLARD

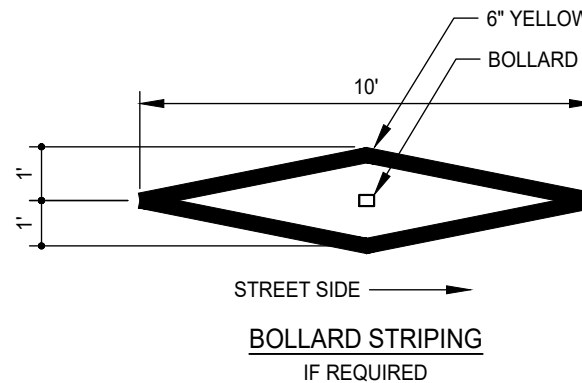

DATE: 09/22/2007		NOT TO SCALE	
REVISION	BY	APPROVED	DATE
1	SJB	SMA	05-01-2025

CITY OF ELK GROVE - PUBLIC WORKS

APPROVED BY:

[Signature] 05-28-2025

CITY ENGINEER

DATE

STATIONARY BOLLARD



DRAWING NUMBER

L - 21

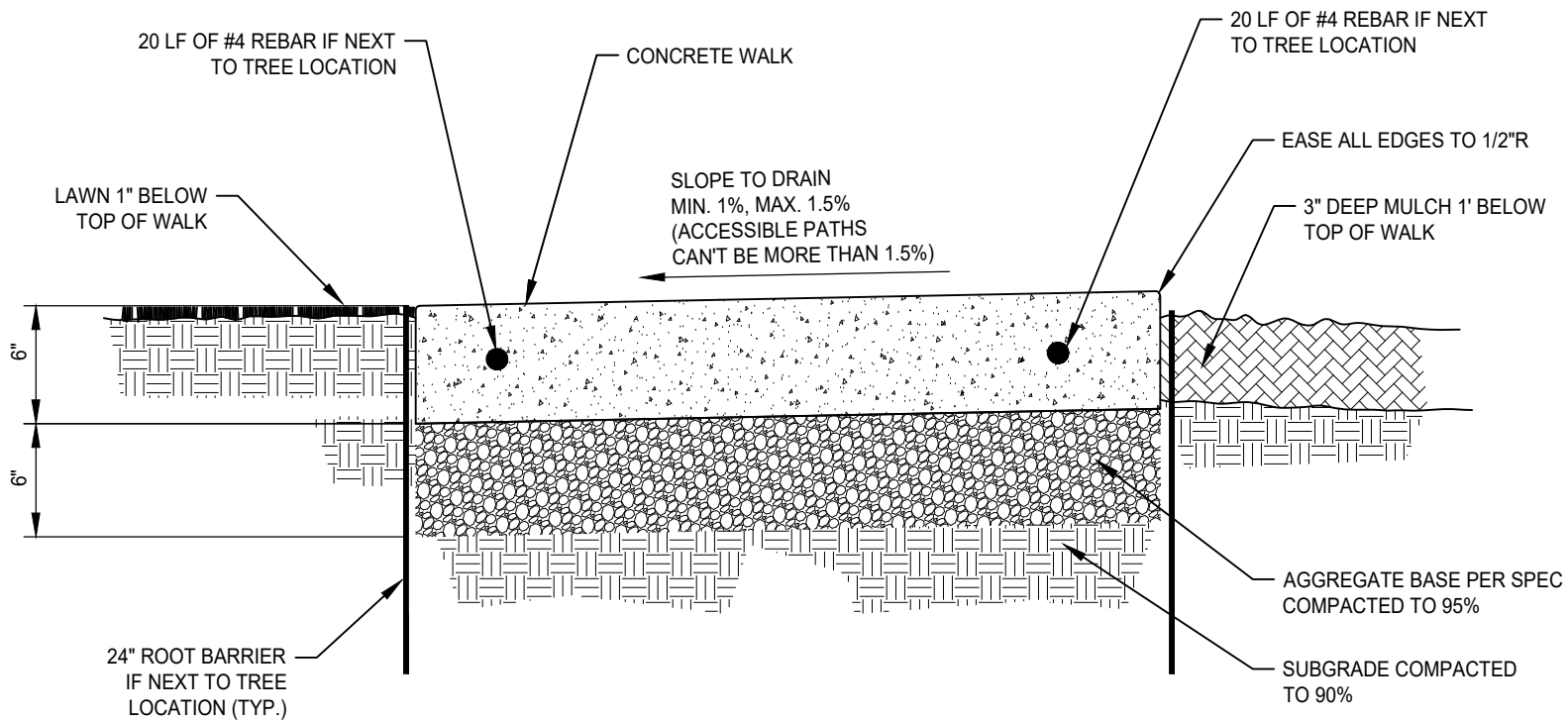

NOTES:

1. PROVIDE 25% OF THICKNESS OR 1.5" DEEP SCORE JOINTS AT 10'-0" ON CENTER.
2. PROVIDE EXPANSION JOINTS AT 20'-0" INTERVALS.
3. CLASS "B" CONCRETE.
4. MEDIUM BROOM FINISH PERPENDICULAR TO WALK EDGE UNLESS OTHERWISE SPECIFIED.
5. PROVIDE FULL DEPTH FELT EXPANSION JOINTS WHEN ABUTTING WALKS, WALLS AND BUILDINGS.

DATE 09/22/2007		NOT TO SCALE	
REVISION	BY	APPROVED	DATE
01	KB	JRW	02/16/2021

CITY OF ELK GROVE - PUBLIC WORKS

**CONCRETE WALK
(IN PARK AREAS, NOT FRONTAGE
AREAS)**

APPROVED BY:
Robert M. Mudgett
CITY ENGINEER

02/17/2021
DATE

DRAWING NUMBER
L - 23



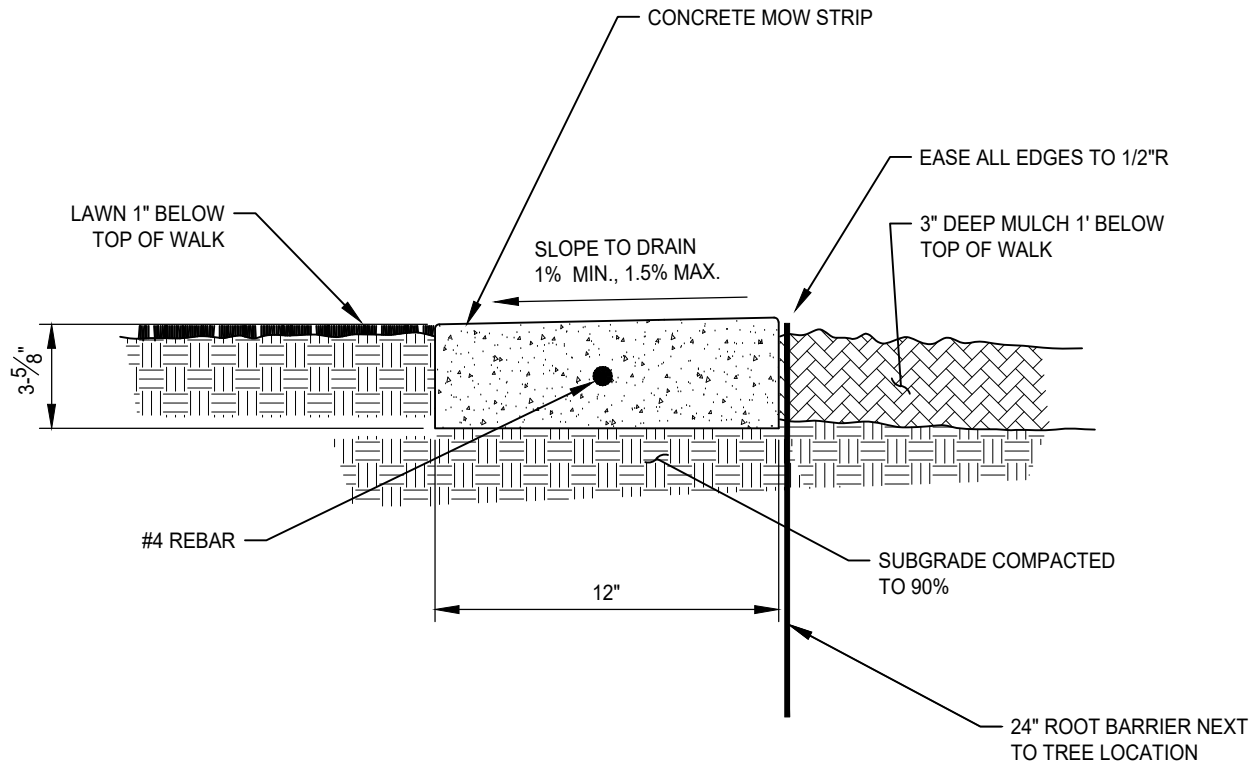

NOTES:

1. PROVIDE 1" DEEP SCORE JOINTS AT 10'-0" ON CENTER.
2. PROVIDE EXPANSION JOINTS AT 20'-0" INTERVALS.
3. CLASS "B" CONCRETE.
4. MEDIUM BROOM FINISH UNLESS OTHERWISE SPECIFIED.
5. PROVIDE FULL DEPTH FELT EXPANSION JOINTS WHEN ABUTTING WALKS, WALLS AND BUILDINGS.

DATE: 09/22/2007		NOT TO SCALE	
REVISION	BY	APPROVED	DATE

CITY OF ELK GROVE - PUBLIC WORKS

CONCRETE MOW STRIP

APPROVED BY:

Paul Murock

CITY ENGINEER

10/24/2018

DATE



DRAWING NUMBER

L - 24

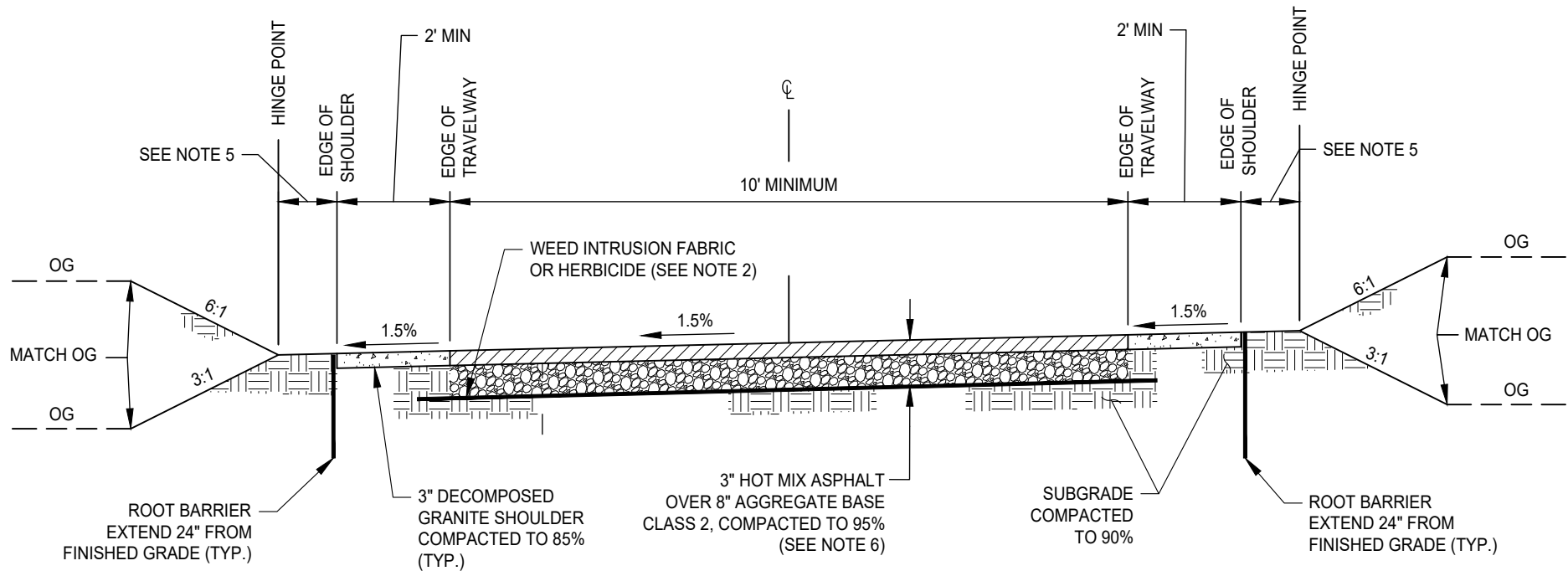

NOTES:

1. APPLY PRE-EMERGENT HERBICIDE UNDER DECOMPOSED GRANITE PRIOR TO INSTALLING IT.
2. APPLY PRE-EMERGENT HERBICIDE OR WEED INTRUSION FABRIC TO AGGREGATE BASE PRIOR TO PAVING ASPHALT CONCRETE.
3. APPLY A 4" WIDE SOLID THERMOPLASTIC YELLOW CENTERLINE STRIPE CONTINUOUSLY DOWN THE CENTER OF THE BIKE TRAIL.
4. A MINIMUM 3-FOOT HORIZONTAL CLEARANCE FROM THE PAVED EDGE OF A BIKE PATH TO OBSTRUCTIONS SHALL BE PROVIDED.
5. FOR TRAILS PARALLEL AND ADJACENT TO CITY STREET, THE TRAIL EDGE OF TRAVELED WAY SHALL BE 5' MINIMUM FROM THE ROADWAY EDGE OF SHOULDER OR 5' MINIMUM FROM THE ROADWAY TOP FACE OF CURB, WHICHEVER IS GREATER.
6. A GEOTECHNICAL RECOMMENDATION IS REQUIRED FOR AN R-VALUE OF LESS THAN 50 TO PROVIDE A DESIGN LIFE OF 20 YEARS AND A TI OF 5.

DATE 09/22/2007		NOT TO SCALE	
REVISION	BY	APPROVED	DATE
01	KB	JRW	02/16/2021

CITY OF ELK GROVE - PUBLIC WORKS

**BIKE TRAIL PAVING
SECTION**

APPROVED BY:

Paul Muddoch 02/17/2021

CITY ENGINEER

DATE



DRAWING NUMBER

L - 25

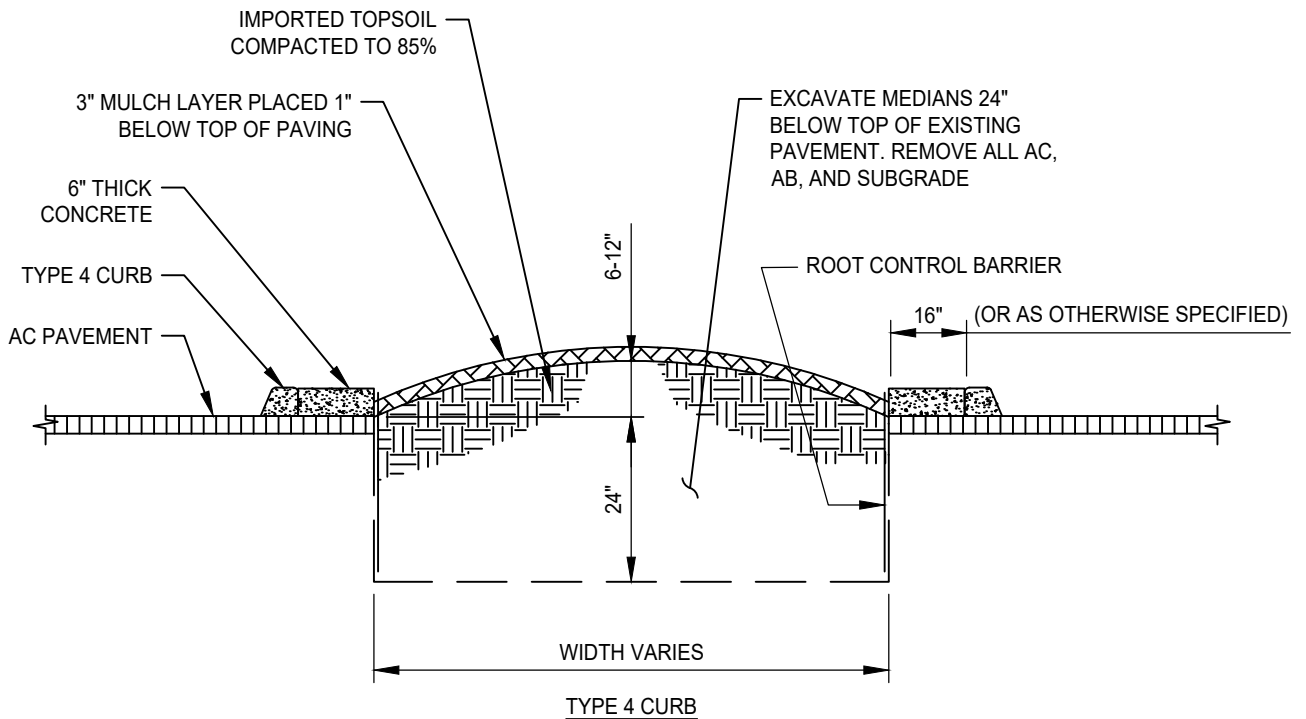
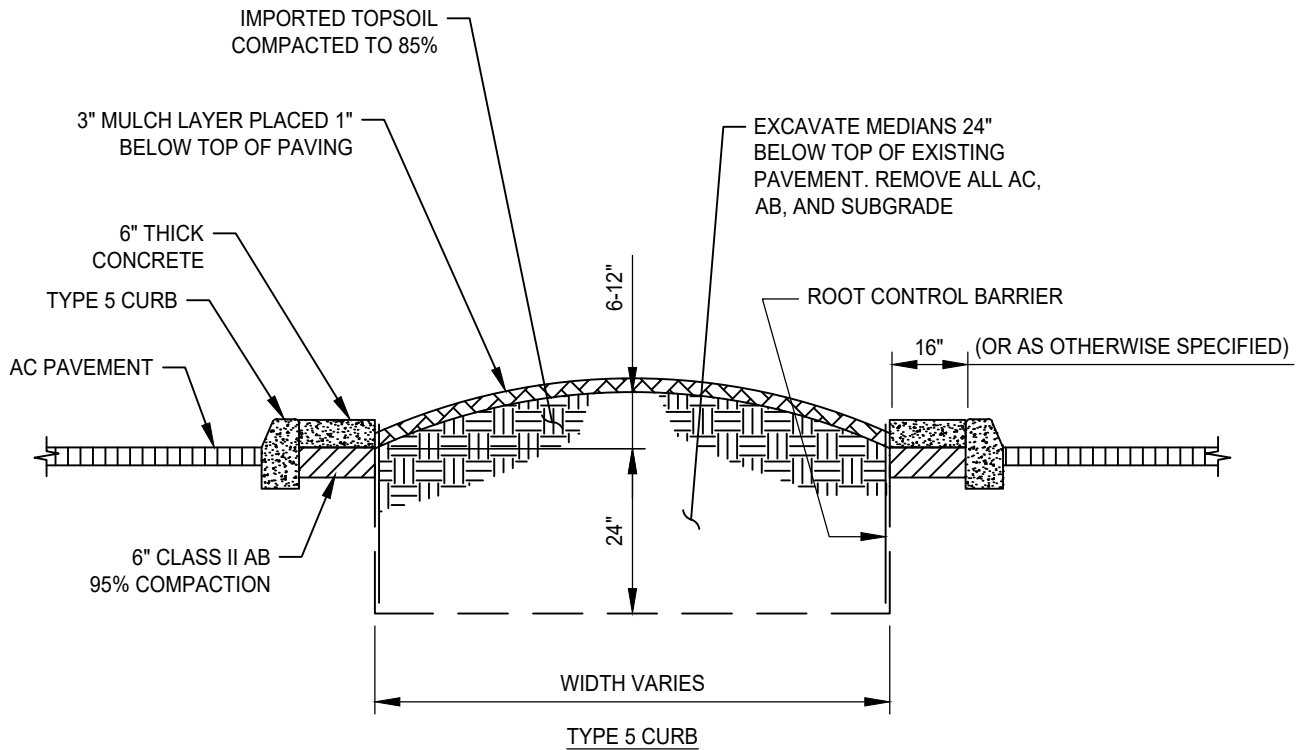

NOTES:

1. CONTOUR OF MEDIAN WILL VARY DEPENDING UPON MEDIAN WIDTH. DO NOT EXCEED BID QUANTITY OF IMPORTED TOPSOIL TO ACHIEVE 12" HEIGHT.

DATE: 09/22/2017		NOT TO SCALE	
REVISION	BY	APPROVED	DATE

CITY OF ELK GROVE - PUBLIC WORKS

APPROVED BY:

Paul Murock

10/24/2018

CITY ENGINEER

DATE

**ROADWAY MEDIAN
SECTION**



DRAWING NUMBER

L - 26

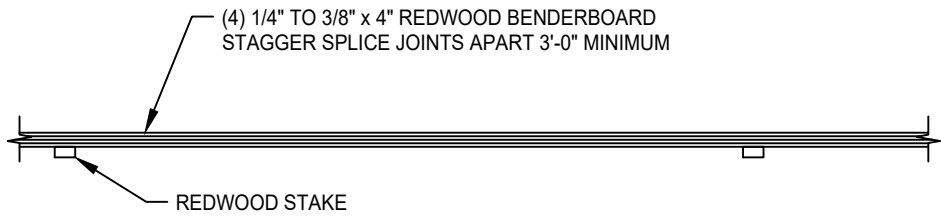

BENDERBOARD PLAN VIEW

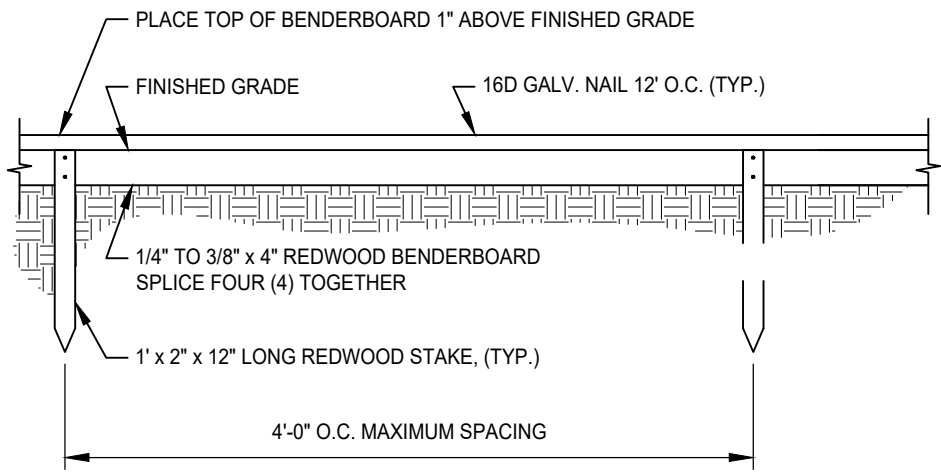

ELEVATION VIEW
1/4\"/>

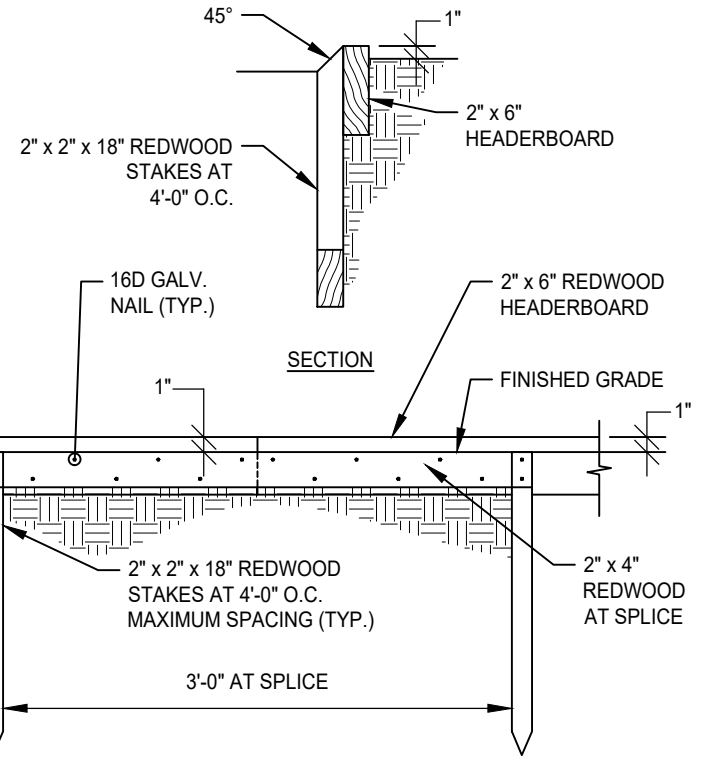

SPLICE DETAIL
2\"/>

NOTES:

1. INSTALL ALL STAKES AND SPLICES ON PLANTING SIDE OF HEADERBOARD.
2. ALL NAILS SHALL BE GALVANIZED.
3. ALL REDWOOD SHALL BE ROUGH CONSTRUCTION COMMON GRADE IN ACCORDANCE TO CALIFORNIA REDWOOD ASSOCIATION GRADING RULES. DRIVE STAKES TO RESISTANCE AND CUT TOP AT 45 DEGREE ANGLE.

DATE: 09/22/2007		NOT TO SCALE	
REVISION	BY	APPROVED	DATE

CITY OF ELK GROVE - PUBLIC WORKS

REDWOOD HEADERBOARD

APPROVED BY:
Paul Murock
CITY ENGINEER

10/24/2018
DATE

DRAWING NUMBER
L - 27



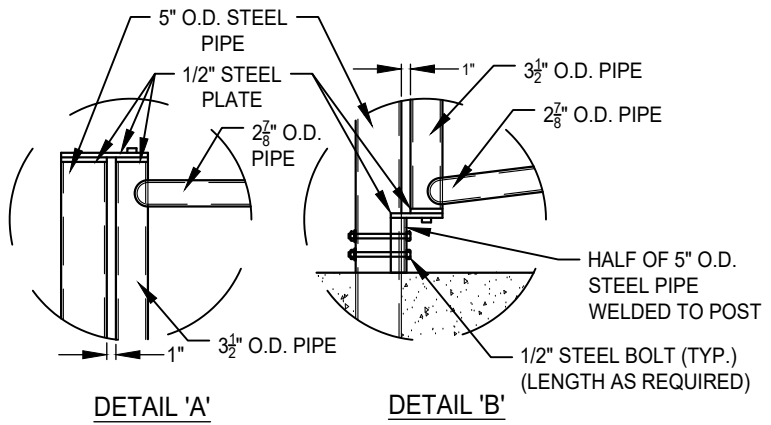
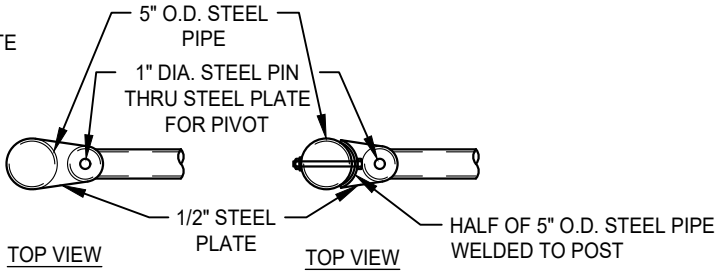
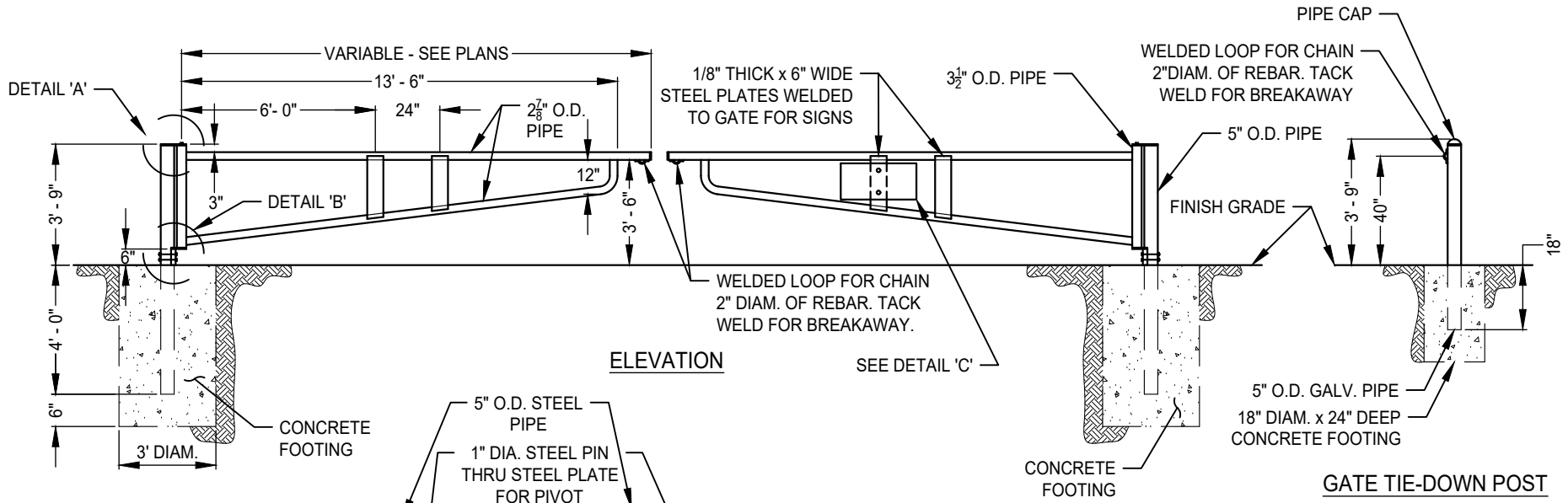

- NOTES:**
1. DOUBLE PIPE GATES SHALL BE USED FOR ROADWAYS OR DRIVEWAYS OVER 24' WIDE OPENING.
 2. ALL PIPES SHALL BE BLACK STEEL PIPES. OUTSIDE DIAMETER (O.D.) AND WELDED.
 3. ALL STEEL TO BE PAINTED WITH 2 COATS OF PRIMER AND SAFETY YELLOW.
 4. PROVIDE TWO (2) 5" O.D. PIPES AND INSTALL WITH CONCRETE FOOTING (18" x 24" D) FOR TIE-DOWN WHEN GATE IS OPENED.
 5. DETAIL 'C' SHALL BE AFFIXED TO PIPE GATE USING (2) THROUGH BOLTS.

24"

18"

PROPERTY OF THE CITY OF ELK GROVE
NO TRESPASSING, DUMPING,
OR ABANDONING OF VEHICLES
AUTHORIZED PERSONNEL
ONLY
VIOLATORS WILL BE PROSECUTED
CA PENAL CODE SEC. 602 AND 374.3
CA VEHICLE CODE 22523 AND 22659

DETAIL 'C'

DATE: 09/22/2007		NOT TO SCALE	
REVISION	BY	APPROVED	DATE
1	SJB	SMA	04-12-2024
2	SJB	SMA	06-18-2025

CITY OF ELK GROVE - PUBLIC WORKS

DOUBLE PIPE GATE

APPROVED BY:  06-20-2025
CITY ENGINEER DATE

DRAWING NUMBER
L - 28



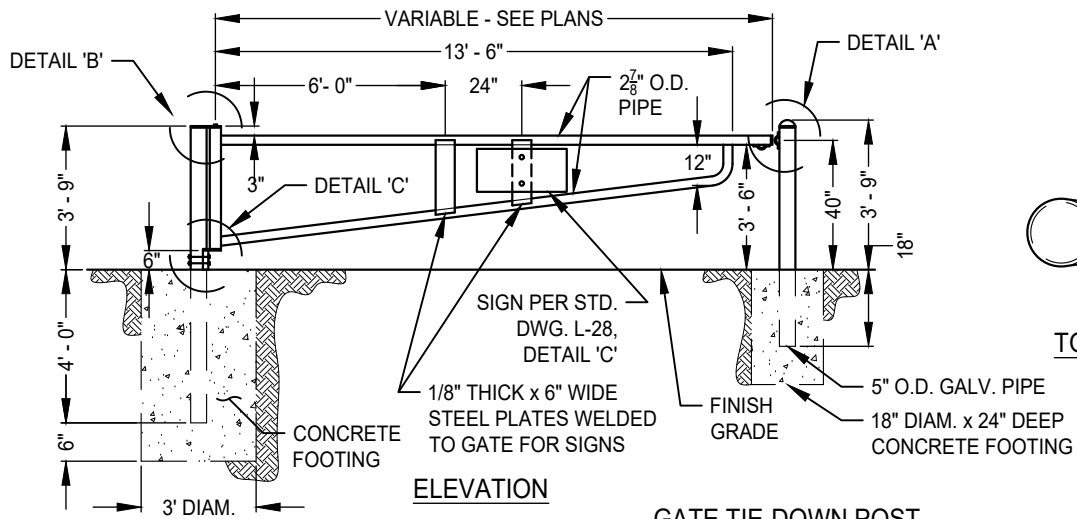

ELEVATION

GATE TIE-DOWN POST

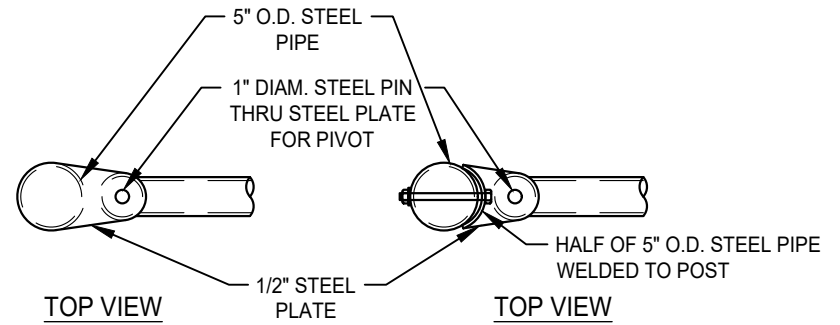

TOP VIEW

TOP VIEW

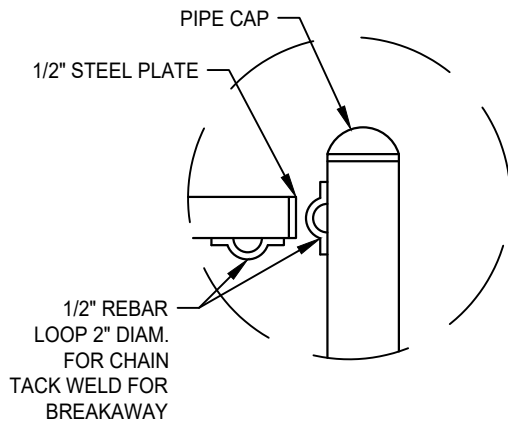

DETAIL 'A'

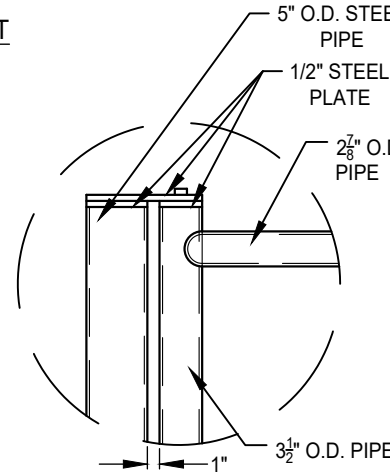

DETAIL 'B'

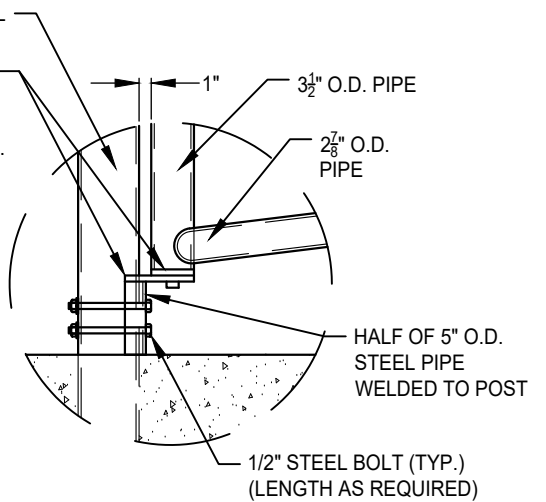

DETAIL 'C'

NOTES:

1. SINGLE PIPE GATE SHALL BE USED FOR ROADWAYS OR DRIVEWAYS UP TO 24' WIDE MAXIMUM OPENING.
2. ALL PIPES SHALL BE BLACK STEEL PIPES. OUTSIDE DIAMETER (O.D.) AND WELDED.
3. ALL STEEL TO BE PAINTED WITH 2 COATS OF PRIMER AND SAFETY YELLOW.
4. PROVIDE TWO (2) 5" O.D. PIPES AND INSTALL WITH CONCRETE FOOTING (18" X 24" D) FOR TIE-DOWN WHEN GATE IS OPENED AND CLOSED.

DATE: 09/22/2007		NOT TO SCALE	
REVISION	BY	APPROVED	DATE
1	SJB	SMA	04-12-2024
2	SJB	SMA	06-18-2025

CITY OF ELK GROVE - PUBLIC WORKS

APPROVED BY:

[Signature] 06-20-2025

CITY ENGINEER

DATE

SINGLE PIPE GATE



DRAWING NUMBER

L - 29

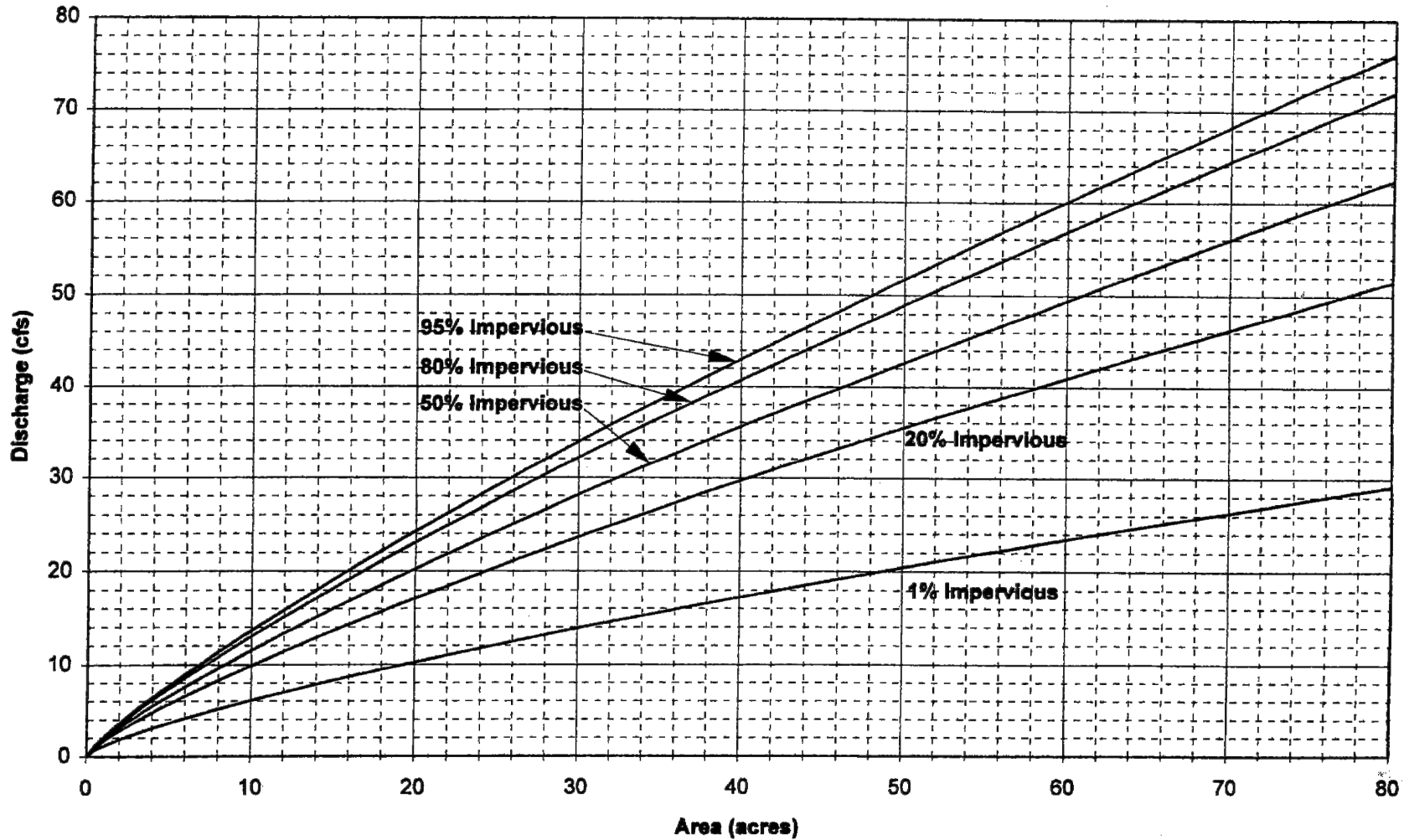

NOTES:

- REFER TO VOLUME 2 HYDROLOGY STANDARDS OF THE CITY/COUNTY DRAINAGE MANUAL FOR ASSUMPTIONS MADE IN DERIVING THIS FIGURE.

DATE: 09/22/2007		NOT TO SCALE	
REVISION	BY	APPROVED	DATE

CITY OF ELK GROVE - PUBLIC WORKS

**10-YEAR PEAK FLOW
SACRAMENTO METHOD
RAINFALL ZONE 2, <80 ACRES**

APPROVED BY:

Paul Murock

CITY ENGINEER

10/24/2018

DATE



DRAWING NUMBER

SD - 1

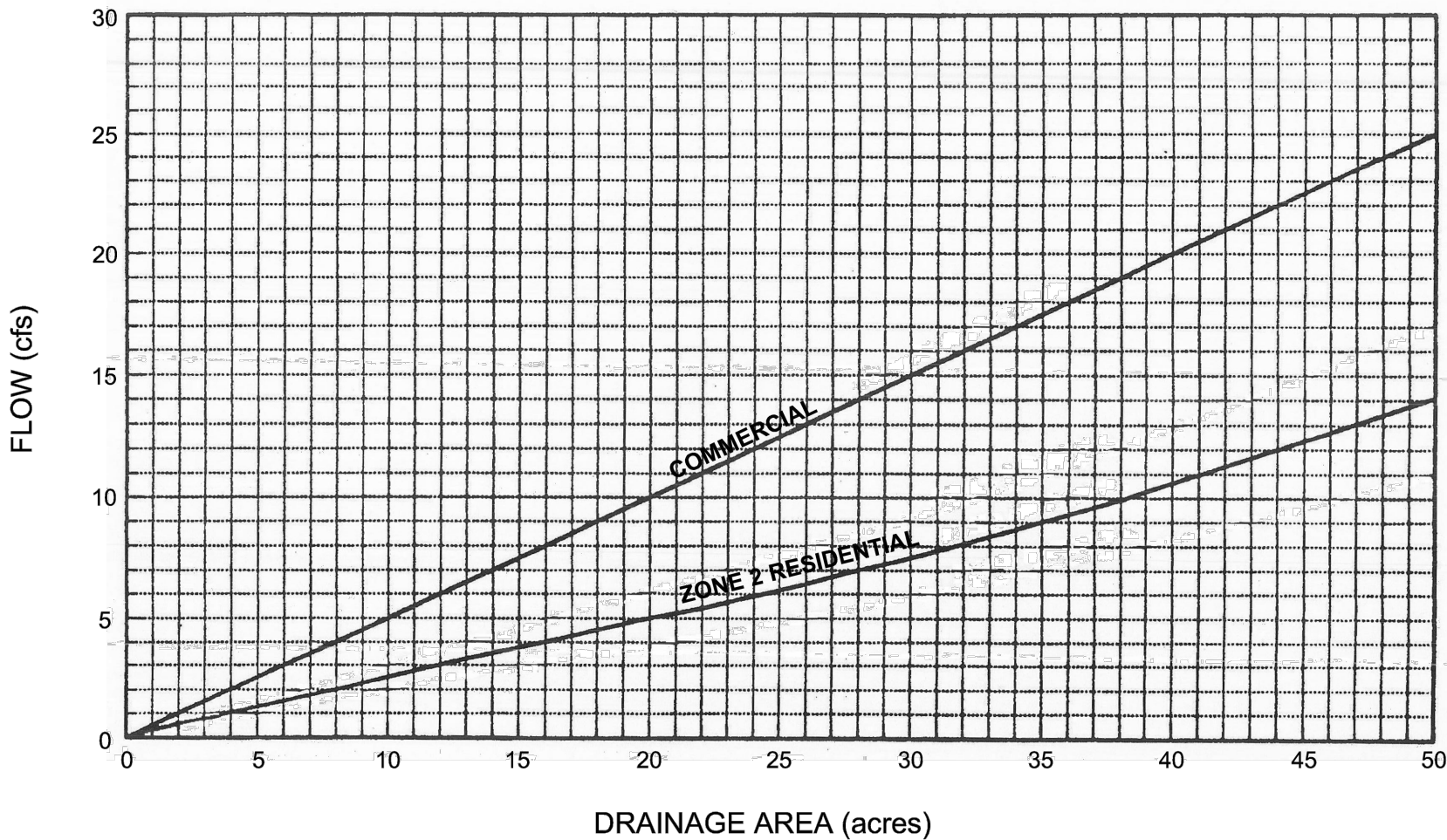

NOTES:

- Design runoff for multiple family development shall be based on the following formula:

$$Q_m = Q_r + (Q_c - Q_r)(I - 50) / 40$$

Where:

- RD-7 I = 60
- RD-10 I = 70
- RD-20 I = 80
- RD-30 I = 90

Source: County of Sacramento Master Drainage Plan, Part 1, County-wide Hydrology, Nolte and Assoc.

DATE: 09/22/2007		NOT TO SCALE	
REVISION	BY	APPROVED	DATE

CITY OF ELK GROVE - PUBLIC WORKS

**DESIGN RUNOFF
NOLTE METHOD
DRAINAGE AREAS, <50 ACRES**

APPROVED BY:

Paul Murock

CITY ENGINEER

10/24/2018

DATE



DRAWING NUMBER

SD - 1A

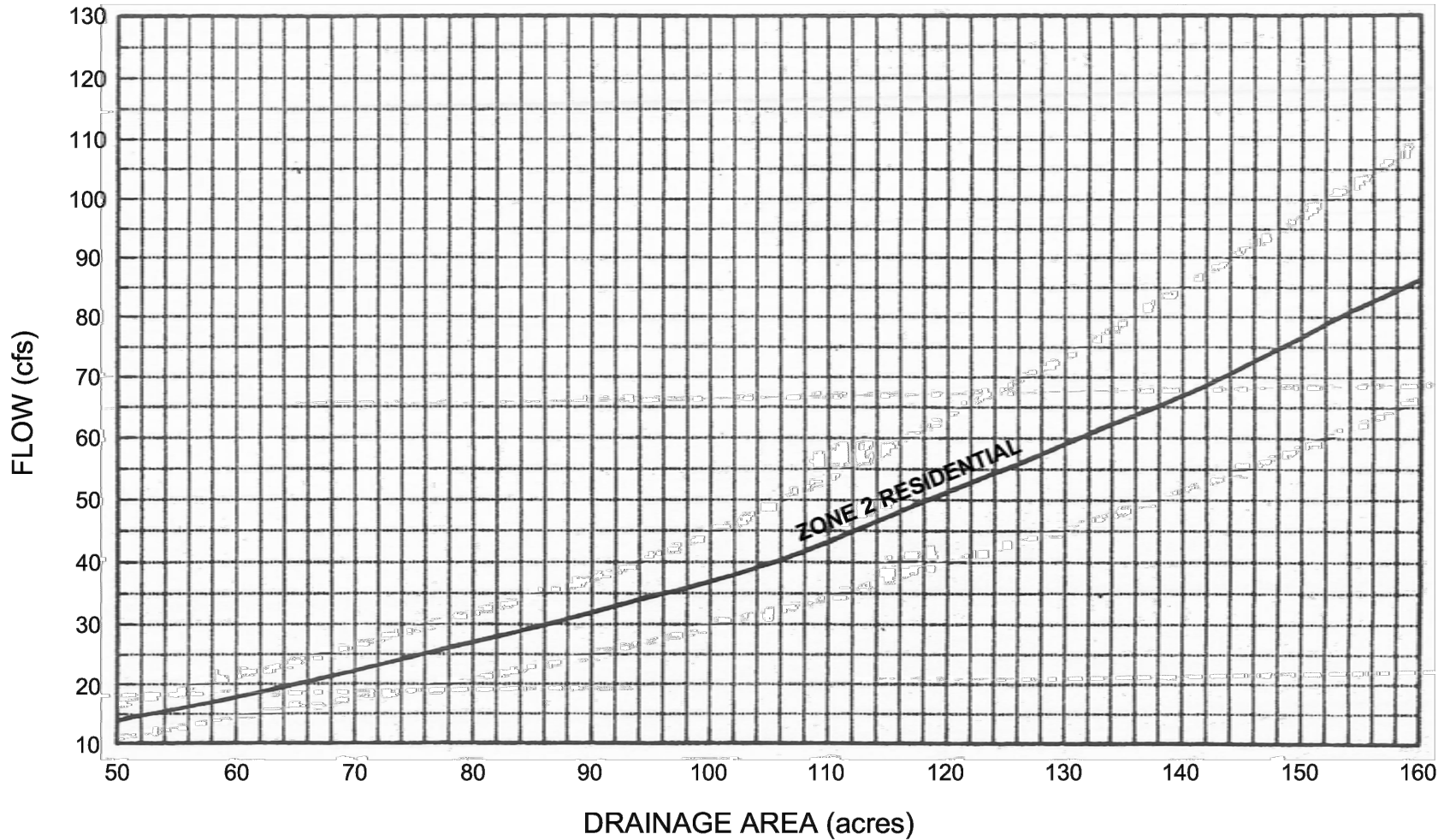

NOTES:

1. Design runoff for multiple family development shall be based on the following formula:

$$Q_m = Q_r + (Q_c - Q_r)(I - 50)/40$$

Where:

- RD-7 I = 60
- RD-10 I = 70
- RD-20 I = 80
- RD-30 I = 90

Source: County of Sacramento Master Drainage Plan, Part 1, County-wide Hydrology, Nolte and Assoc.

DATE: 09/22/2007		NOT TO SCALE	
REVISION	BY	APPROVED	DATE

CITY OF ELK GROVE - PUBLIC WORKS

**DESIGN RUNOFF
NOLTE METHOD
RESIDENTIAL AREAS, 50-160 ACRES**

APPROVED BY:

Paul Murock

CITY ENGINEER

10/24/2018

DATE



DRAWING NUMBER

SD - 1B

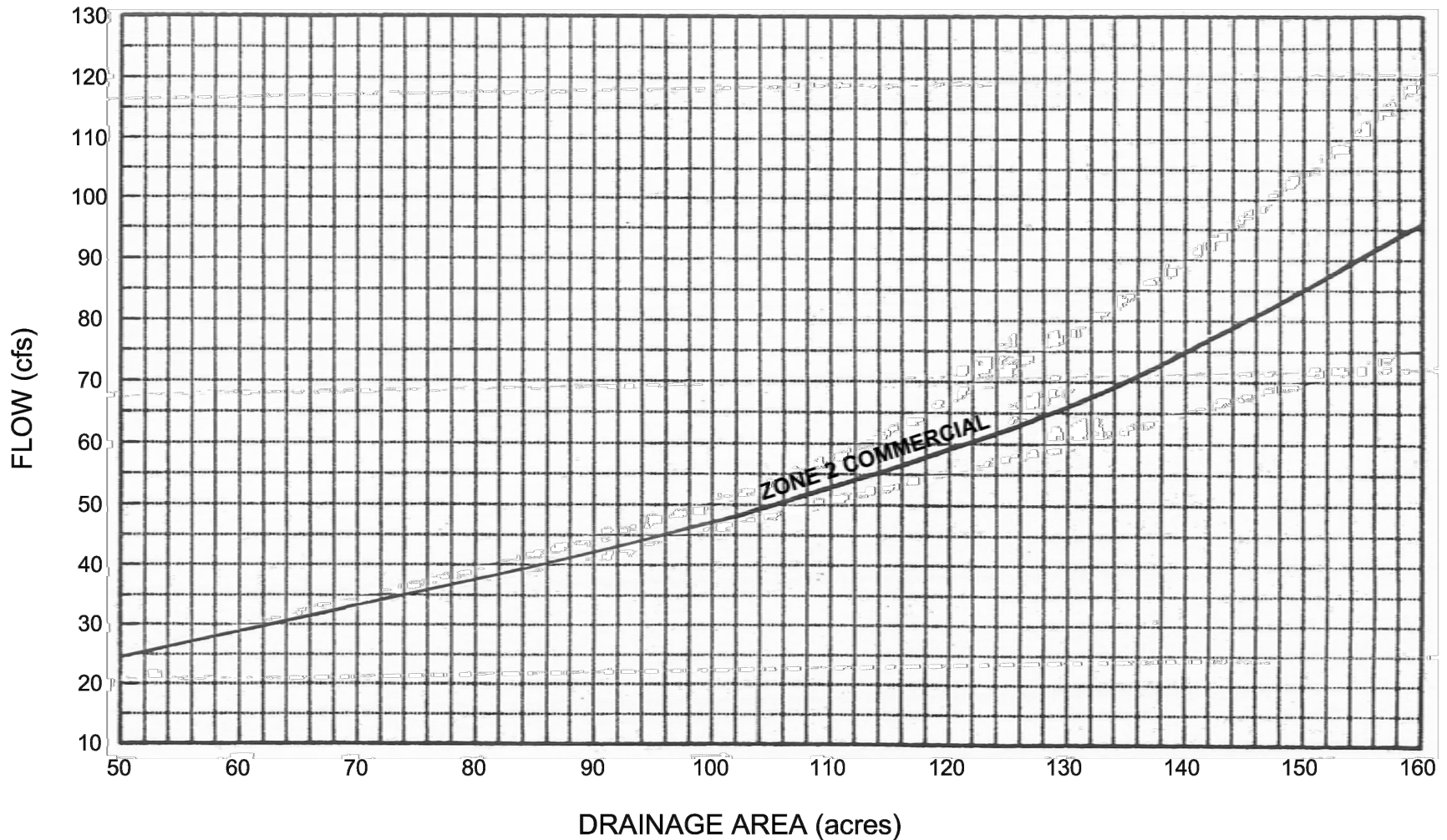

Source: County of Sacramento Master Drainage Plan, Part 1, County-wide Hydrology, Nolte and Assoc.

DATE: 09/22/2007		NOT TO SCALE	
REVISION	BY	APPROVED	DATE

CITY OF ELK GROVE - PUBLIC WORKS

**DESIGN RUNOFF
NOLTE METHOD
COMMERCIAL AREAS, 50-160 ACRES**

APPROVED BY:
Paul Murock
CITY ENGINEER

10/24/2018
DATE

DRAWING NUMBER
SD - 1C



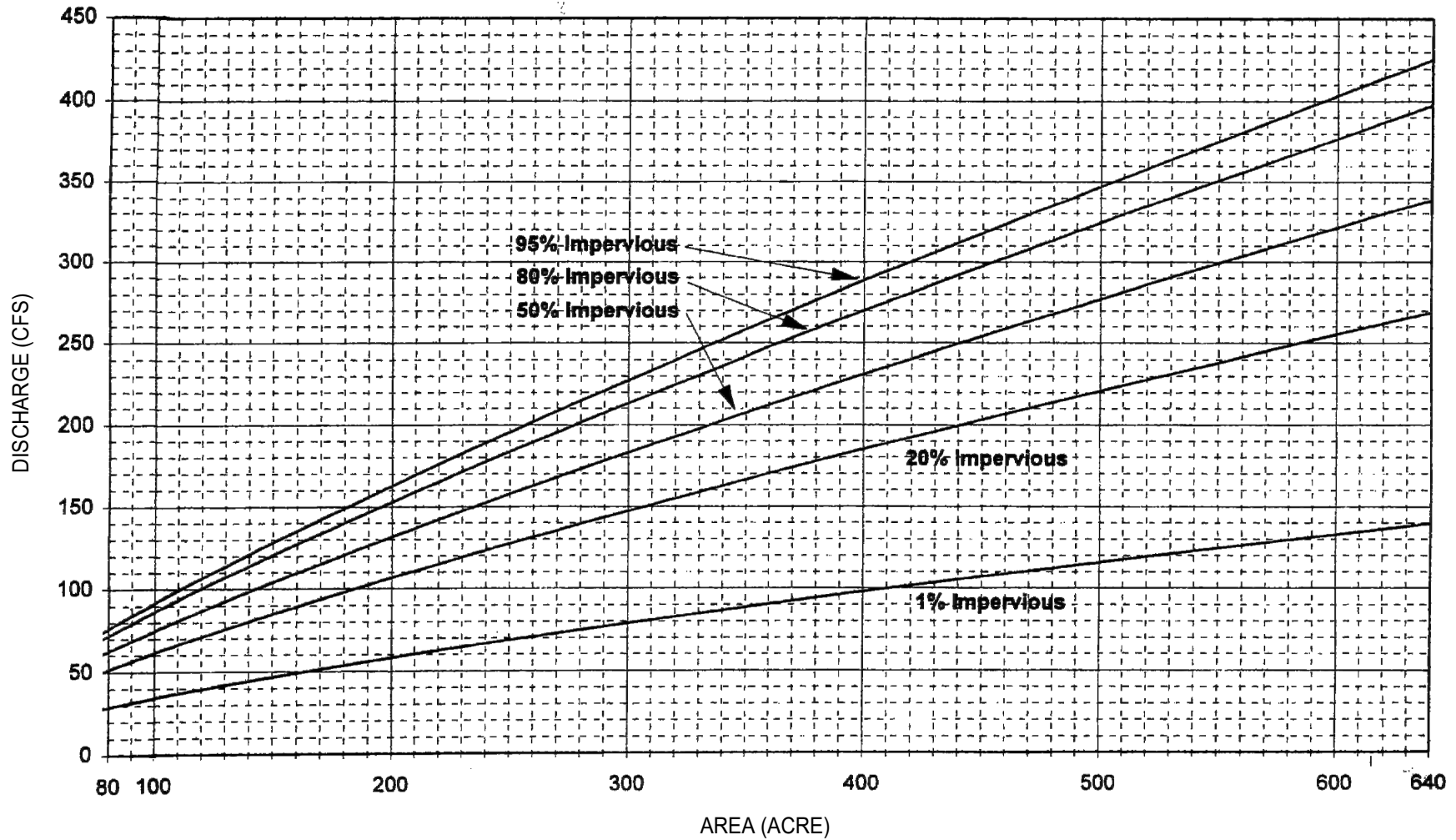

NOTES:

- REFER TO VOLUME 2 HYDROLOGY STANDARDS OF THE CITY/COUNTY DRAINAGE MANUAL FOR ASSUMPTIONS MADE IN DERIVING THIS FIGURE.

DATE: 09/22/2007		NOT TO SCALE	
REVISION	BY	APPROVED	DATE

CITY OF ELK GROVE - PUBLIC WORKS

**10-YEAR PEAK FLOW
SACRAMENTO METHOD
RAINFALL ZONE 2, 80-640 ACRES**

APPROVED BY:
Paul Murock
CITY ENGINEER

10/24/2018
DATE

DRAWING NUMBER
SD - 2



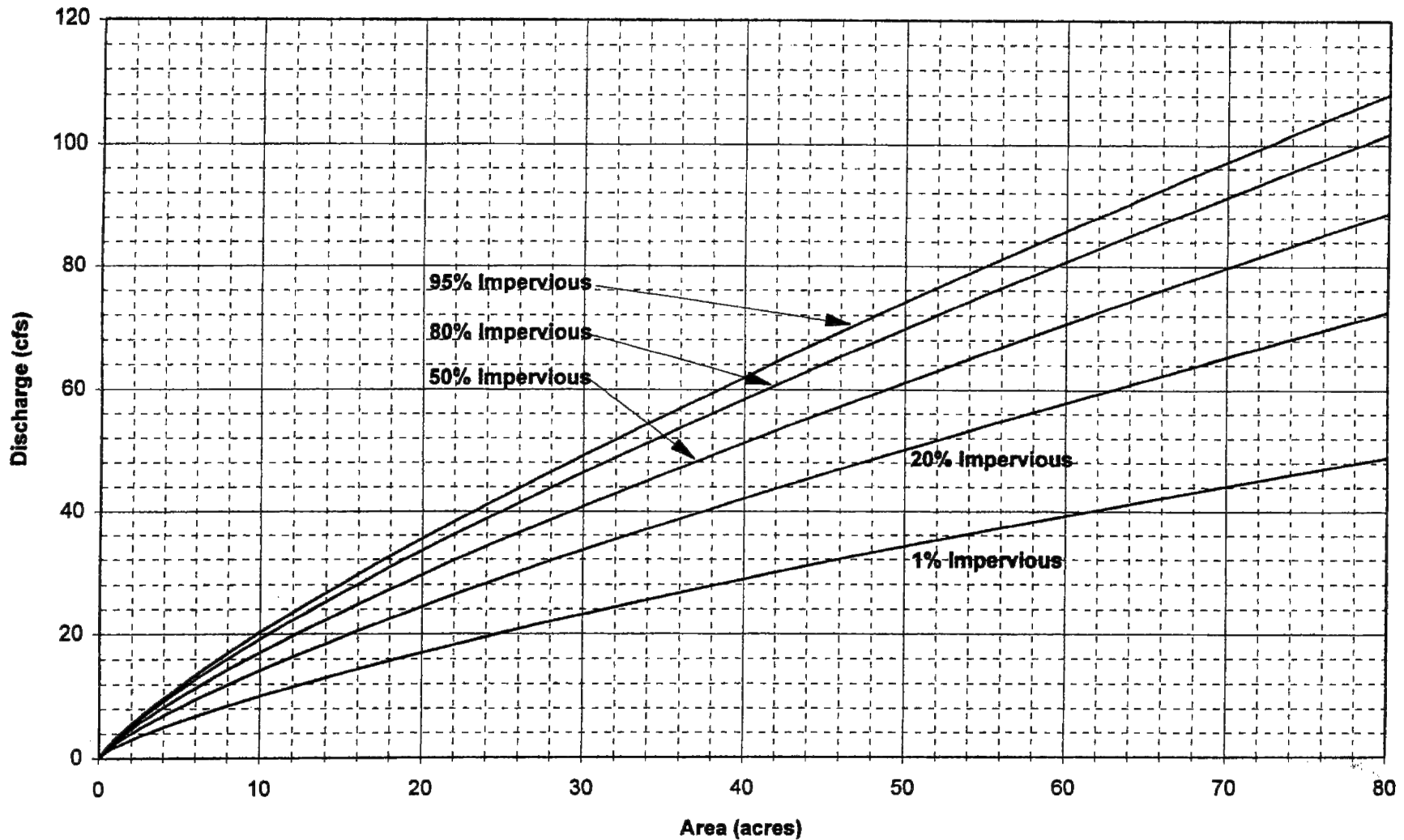

NOTES:

- REFER TO VOLUME 2 HYDROLOGY STANDARDS OF THE CITY/COUNTY DRAINAGE MANUAL FOR ASSUMPTIONS MADE IN DERIVING THIS FIGURE.

DATE: 09/22/2007		NOT TO SCALE	
REVISION	BY	APPROVED	DATE

CITY OF ELK GROVE - PUBLIC WORKS

**100-YEAR PEAK FLOW
SACRAMENTO METHOD
RAINFALL ZONE 2, <80 ACRES**

APPROVED BY:

Paul Murock

CITY ENGINEER

10/24/2018

DATE



DRAWING NUMBER

SD - 3

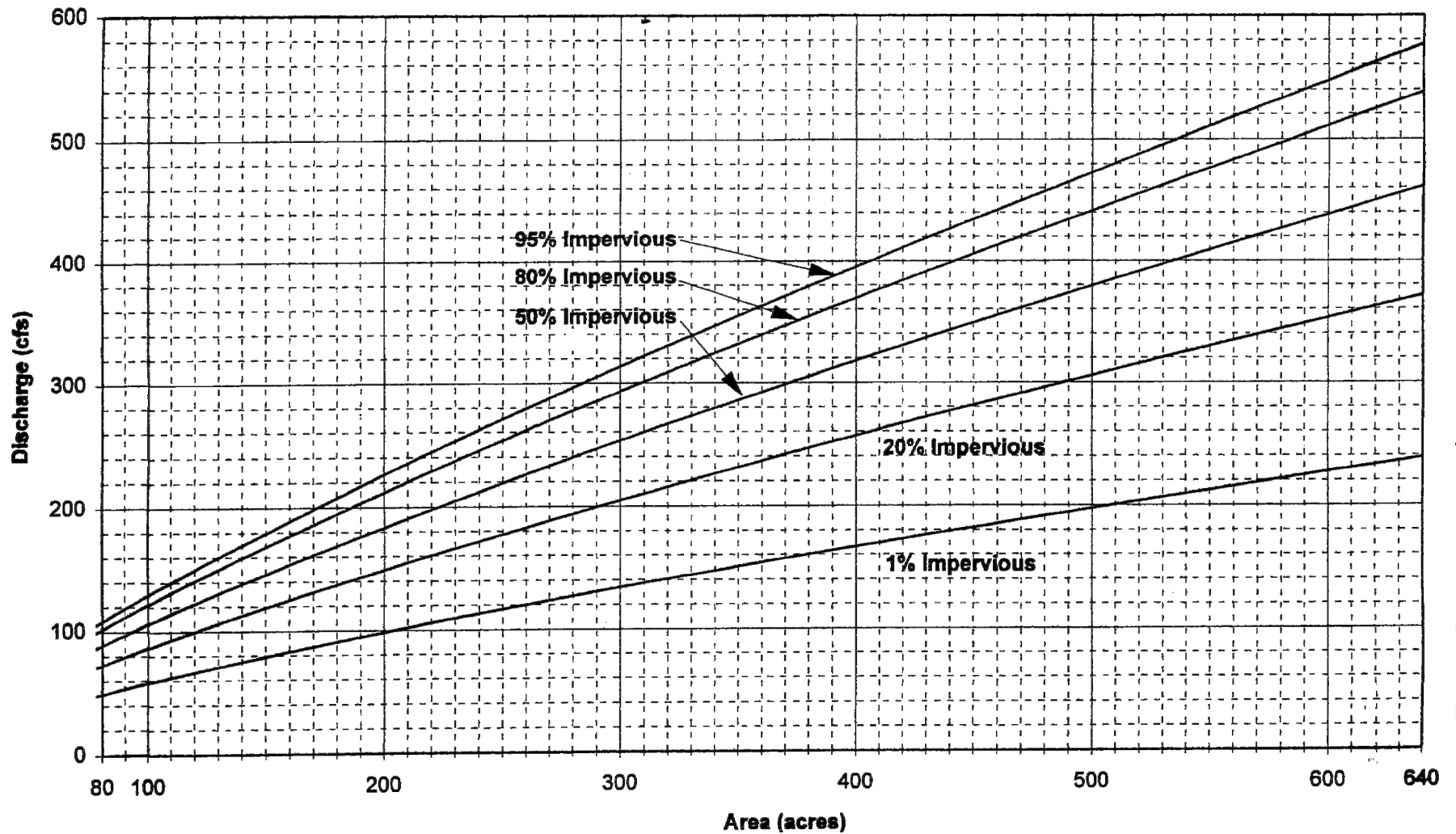

NOTES:

- REFER TO VOLUME 2 HYDROLOGY STANDARDS OF THE CITY/COUNTY DRAINAGE MANUAL FOR ASSUMPTIONS MADE IN DERIVING THIS FIGURE.

DATE: 09/22/2007		NOT TO SCALE	
REVISION	BY	APPROVED	DATE

CITY OF ELK GROVE - PUBLIC WORKS

**100-YEAR PEAK FLOW
SACRAMENTO METHOD
RAINFALL ZONE 2, 80-640 ACRES**

APPROVED BY:
Paul Murock
CITY ENGINEER

10/24/2018
DATE

DRAWING NUMBER
SD - 4



Degree of Angle "A" Between Lateral & Outlet

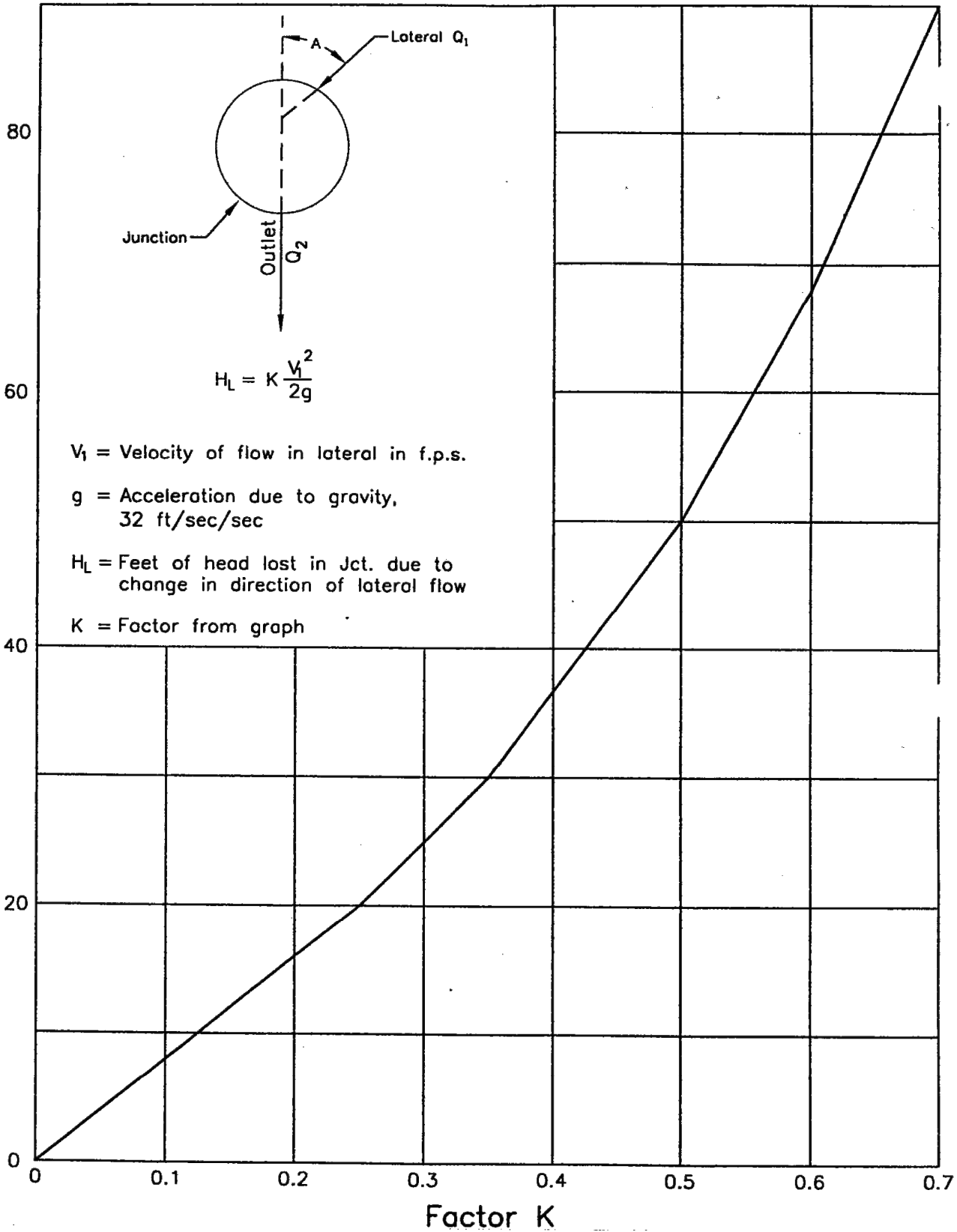

DATE: 09/22/2017		NOT TO SCALE	
REVISION	BY	APPROVED	DATE

CITY OF ELK GROVE - PUBLIC WORKS

LOSS IN JUNCTION DUE TO CHANGE IN DIRECTION OF FLOW IN LATERAL

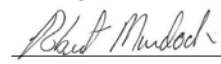
APPROVED BY:

 CITY ENGINEER

10/24/2018
 DATE

DRAWING NUMBER
SD - 5

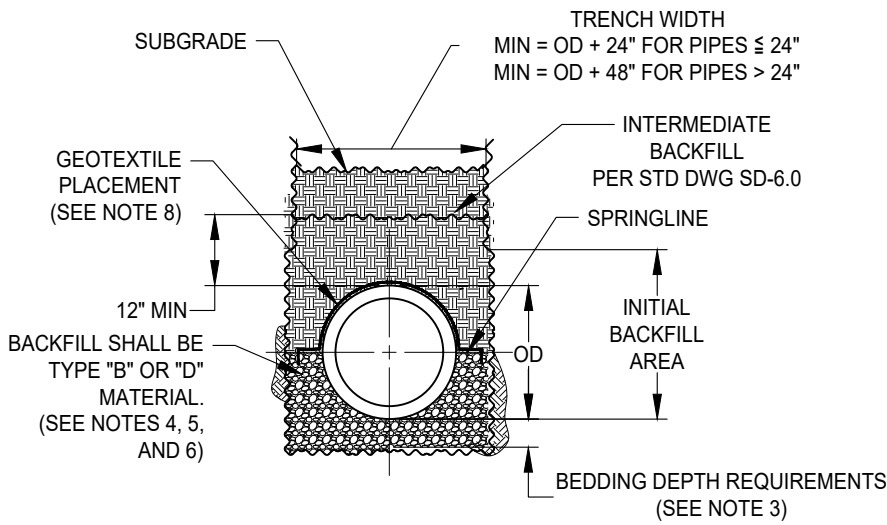



BACKFILL REQUIREMENTS

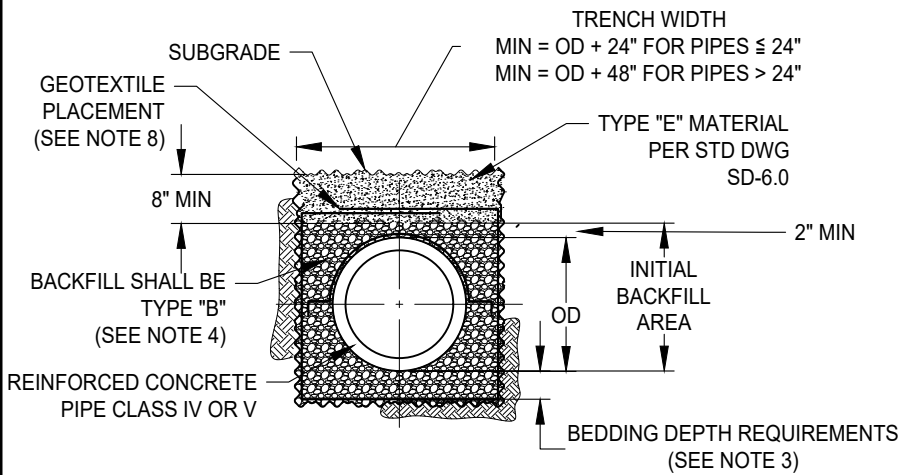

**BACKFILL REQUIREMENTS FOR SHALLOW PIPE -
OPTION 1**

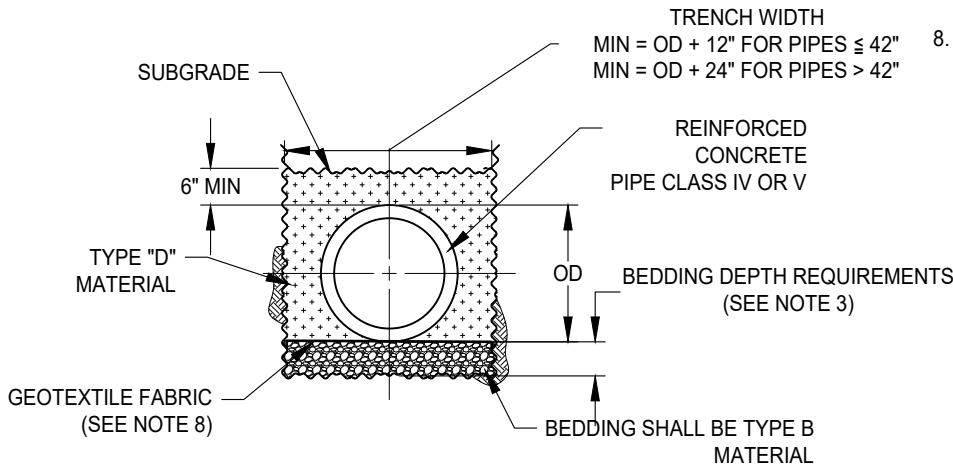

**BACKFILL REQUIREMENTS FOR SHALLOW PIPE -
OPTION 2**

NOTES:

1. INITIAL BACKFILL MATERIAL SHALL BE THOROUGHLY COMPACTED AROUND PIPE AS PER SECTION 19 OF THE CITY STANDARD CONSTRUCTION SPECIFICATIONS.
2. "TRENCH EXCAVATION, BEDDING AND BACKFILL" AS PER SECTION 19 OF THE CITY STANDARD CONSTRUCTION SPECIFICATIONS.
3. MINIMUM DEPTH OF BEDDING SHALL BE THE GREATER OF:
4" MIN FOR PIPES WITH ID ≤ 48"
6" MIN FOR PIPES WITH ID > 48"
OR
THE DIFFERENCE BETWEEN THE OD OF THE PIPE BARREL AND THE BELL PLUS 1.5".

FOR ROCKY OR UNSUITABLE BEDDING CONDITIONS, SEE SECTION 19 OF THE CITY STANDARD CONSTRUCTION SPECIFICATIONS FOR TYP. BEDDING REQUIREMENTS.

4. IF MINIMUM TRENCH WIDTH CANNOT BE ACHIEVED, TYPE "D" MATERIAL SHALL BE USED IN LIEU OF TYPE "B" MATERIAL AT NO EXTRA COST.
5. IF BOTTOM OF ROADWAY STRUCTURAL SECTION (SUBGRADE) IS WITHIN 12" OF TOP OF PIPE, BEDDING AND INITIAL BACKFILL SHALL BE PER ONE OF THE TWO SHALLOW PIPE DETAILS ON THIS SHEET.
6. FOR ADDITIONAL INITIAL BACKFILL MATERIAL OPTIONS FOR 48" AND LARGER RCP, SEE SECTION 19 OF THE CITY STANDARD CONSTRUCTION SPECIFICATIONS.
7. SEE STD DWG SD-6.0 AND SECTION 19 OF THE CITY STANDARD CONSTRUCTION SPECIFICATIONS FOR BACKFILL MATERIAL DEFINITIONS AND ADDITIONAL REQUIREMENTS.
8. GEOTEXTILE FABRIC SHALL BE INSTALLED AS FOLLOWS FOR RCP & PLASTIC PIPE:

- PER SECTION 19 OF CITY STANDARD CONSTRUCTION SPECIFICATIONS.
- FOR DRY TRENCH CONDITIONS - PLACE ON TOP OF THE TYPE B MATERIAL. EXTENDING A 2" EDGE FACING DOWN ON THE TRENCH SIDES.
- FOR SATURATED TRENCH CONDITIONS - WRAP TYPE B MATERIALS WITH GEOTEXTILE FABRIC. OVERLAP THE FABRIC EDGES AT LEAST TWO FEET (2') ON TOP.

DATE 02-16-2022		NOT TO SCALE	
REVISION	BY	APPROVED	DATE
1	STN	SA	02-16-2022
2	SJB	SMA	03-12-2025

CITY OF ELK GROVE - PUBLIC WORKS

**STORM DRAIN REINFORCED
CONCRETE PIPE BEDDING AND
INITIAL BACKFILL**

APPROVED BY: _____
03-24-2025
 CITY ENGINEER DATE

DRAWING NUMBER
SD - 6.1



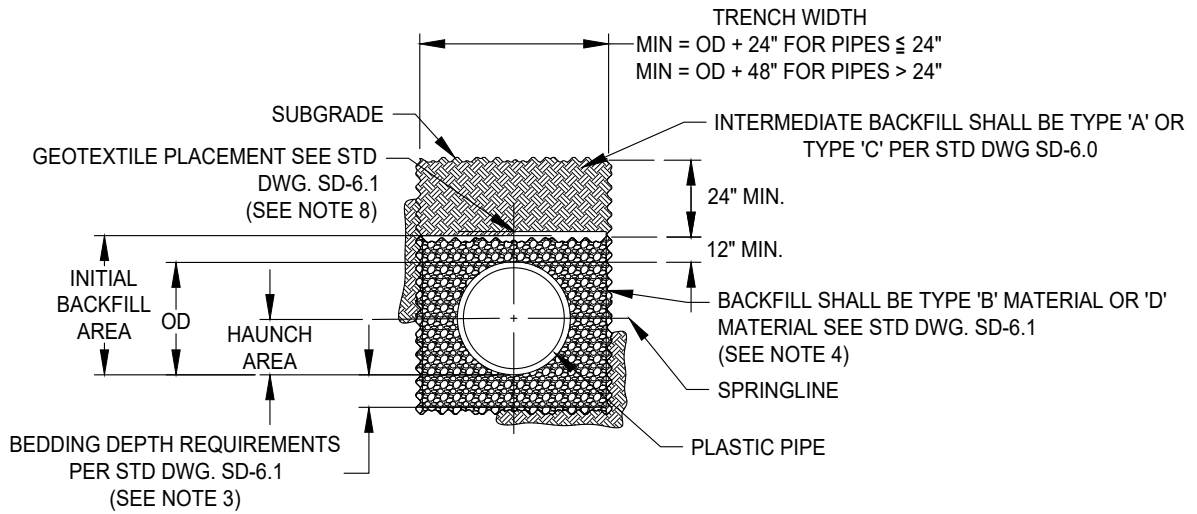

BACKFILL REQUIREMENTS FOR PLASTIC PIPE 12" TO 42" DIAMETER ONLY

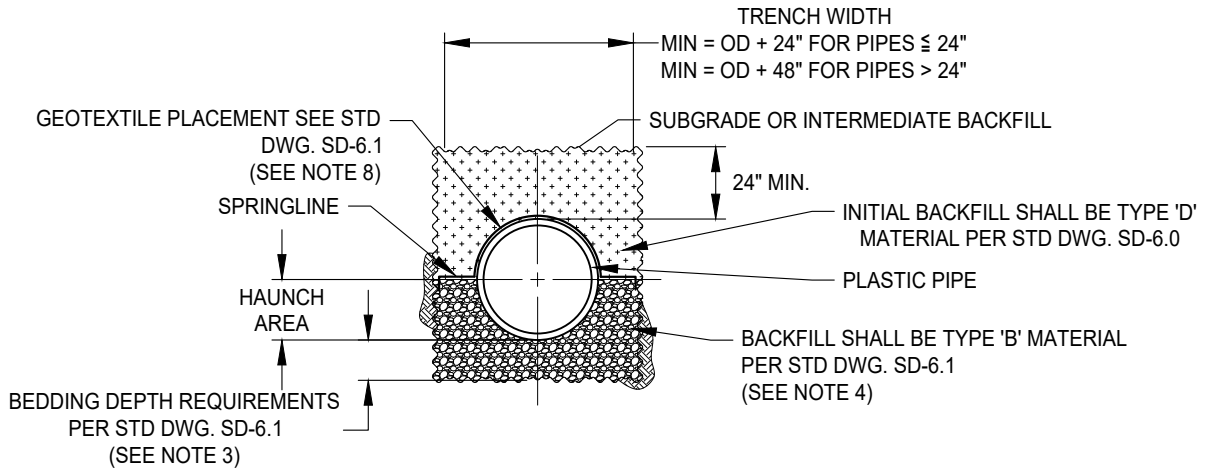

INITIAL BACKFILL REQUIREMENTS FOR PLASTIC PIPE (12" TO 60" DIAMETER) - OPTION 1

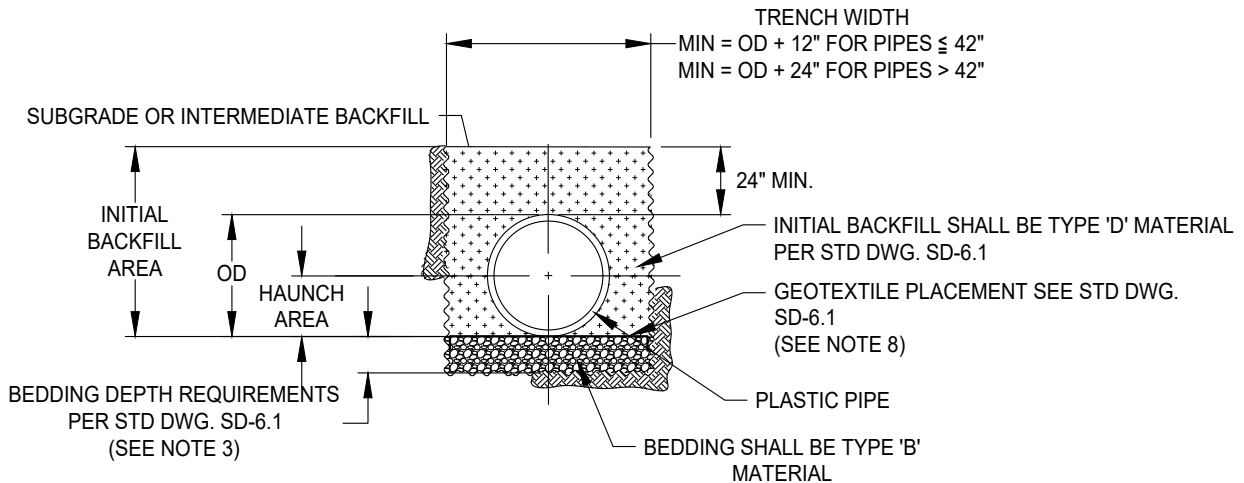

INITIAL BACKFILL REQUIREMENTS FOR PLASTIC PIPE (12" TO 60" DIAMETER) - OPTION 2

DATE 02-16-2022		NOT TO SCALE	
REVISION	BY	APPROVED	DATE
1	STN	SA	02-16-2022
2	SJB	SMA	03-12-2025

CITY OF ELK GROVE - PUBLIC WORKS

**STORM DRAIN PLASTIC PIPE
BEDDING AND INITIAL BACKFILL**

APPROVED BY: _____ 03-24-2025
 CITY ENGINEER DATE

DRAWING NUMBER
SD - 6.2



FLOW
↓

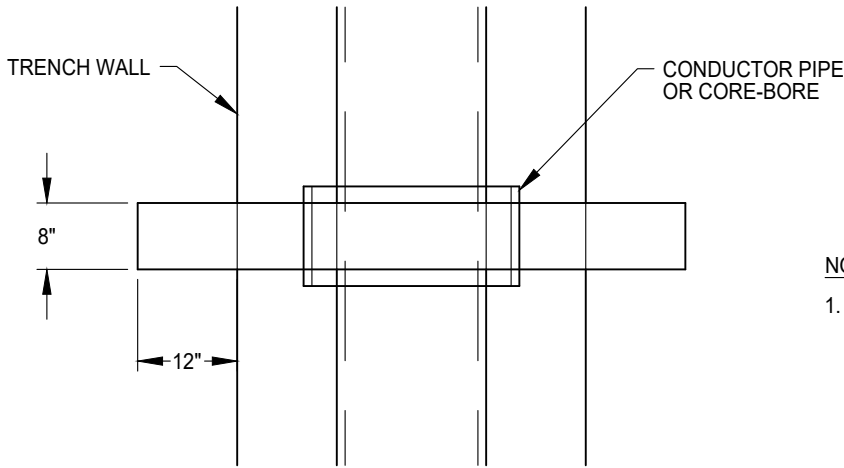

NOTES:

1. TOP OF COLLAR TO EXTEND INTO INTERMEDIATE BACKFILL 12" MINIMUM OR TOP OF GROUND WATER HGL.

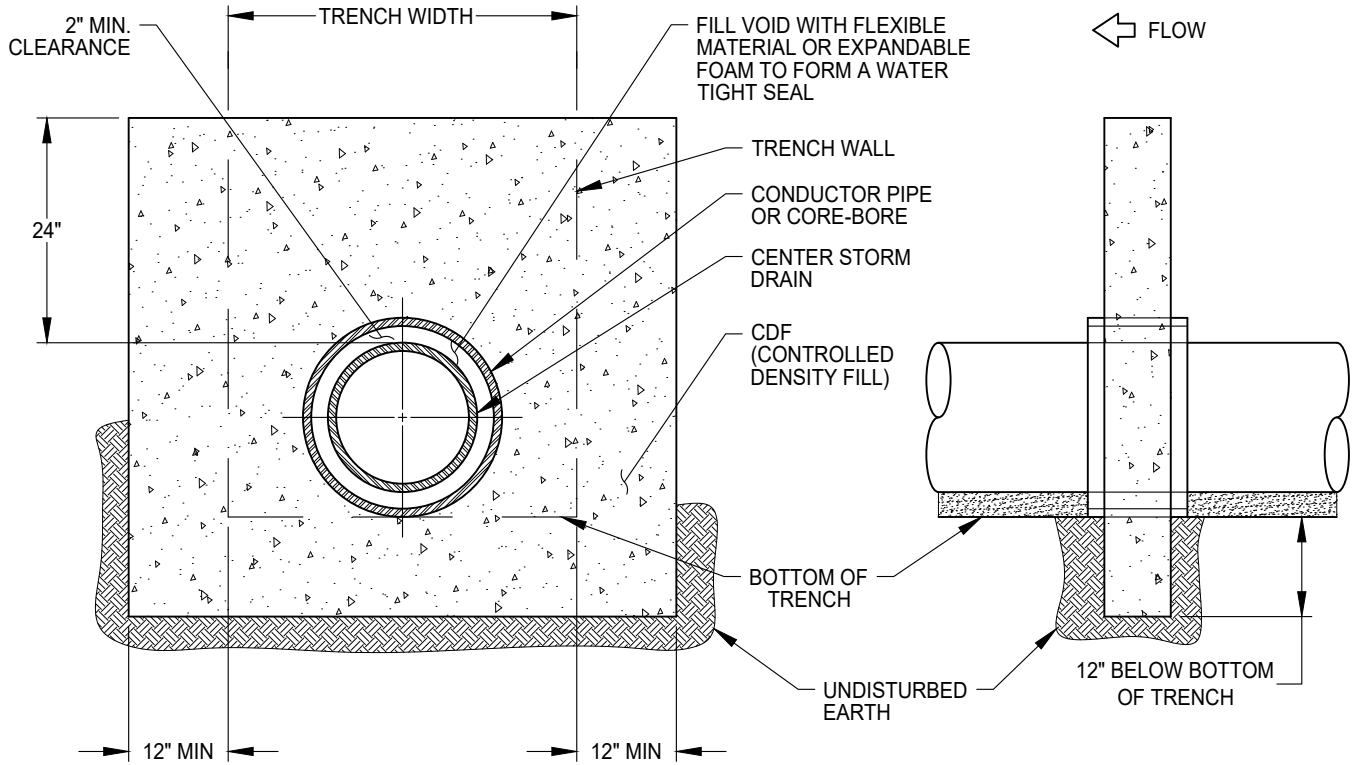

DATE 02-16-2022		NOT TO SCALE	
REVISION	BY	APPROVED	DATE
01	STN	SA	02-16-2022

CITY OF ELK GROVE - PUBLIC WORKS

APPROVED BY:
Jeffrey B. Wan 04-29-2024
CITY ENGINEER DATE

CUTOFF COLLAR



DRAWING NUMBER

SD - 6.3

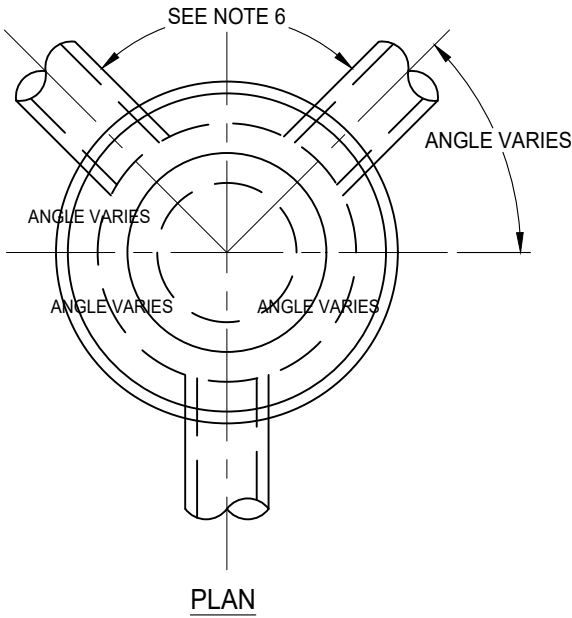
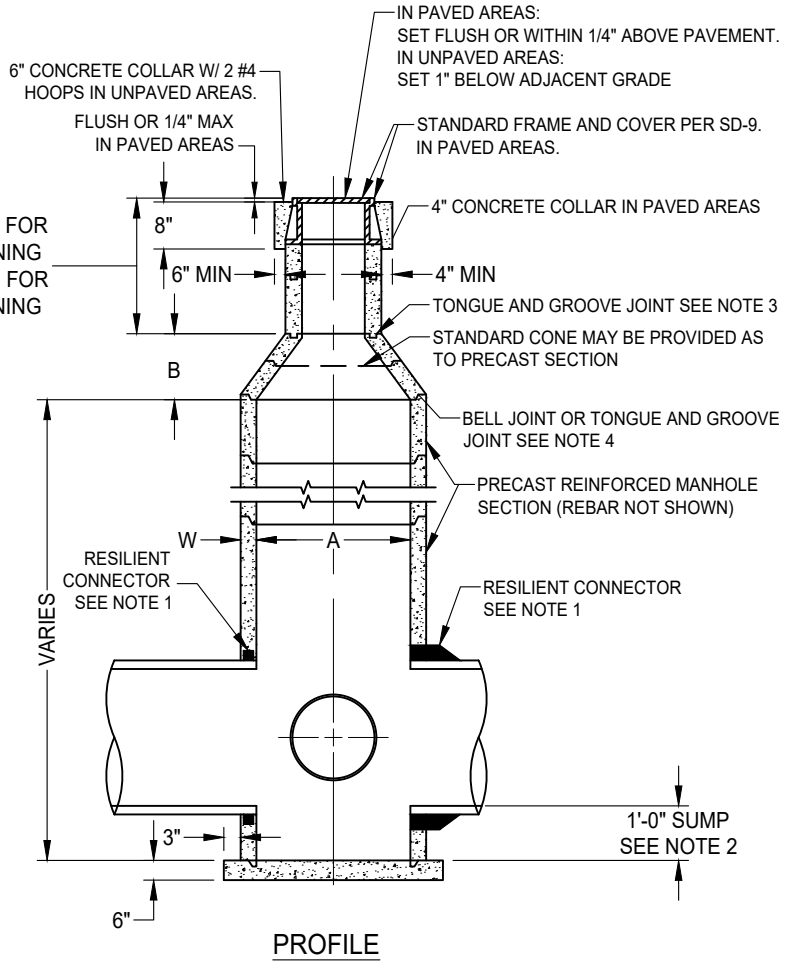

TABLE OF MINIMUM DIMENSIONS

M.H.	A	B	T*	W
48"	48"	18"	8"	4'
60"	60"	28"	9"	6'
72"	72"	SEE NOTE 8	10"	7'



NOTES:

- ON ALL PIPES UP TO 30" I.D. USE FLEXIBLE COMPRESSION GASKET OR BOOT CONNECTOR CONFORMING TO ASTM C-923. CONNECTION SHALL BE WATER AND SOIL TIGHT. FOR PIPES GREATER THAN 30" I.D., BASE MAY BE CAST-IN-PLACE (SEE SD 7.1) AND A WATER STOP CONFORMING TO ASTM C-923 SHALL BE USED.
- SUMP SHALL BE 1'-0" DEEP, MEASURED FROM INVERT OF OUTFALL PIPE. SUMP NOT REQUIRED IF OUTFALL PIPE IS 24" I.D. OR LARGER.
- RISER SECTIONS, CONES, AND ADJUSTING RINGS SHALL CONFORM TO ASTM C-478.
- ALL JOINTS SHALL BE MADE WITH PREFORMED PLASTIC JOINT SEALING COMPOUND. FOLLOWING INSTALLATION GROUT ALL INTERIOR AND EXTERIOR JOINTS.
- CONCENTRIC COMPONENTS SHALL BE USED UNLESS OTHERWISE SPECIFIED ON THE PLANS.
- PRECAST MANHOLES SHALL BE SIZED TO PROVIDE THE FOLLOWING: THE ANNULAR SPACE ON THE INSIDE OF THE MANHOLE BARREL BETWEEN CORED PIPE CONNECTION HOLES SHALL BE A MINIMUM OF 10 INCHES, IF THE CONNECTION HOLE IS CAST MONOLITHICALLY WITH THE MANHOLE BARREL THE MEASUREMENT SHALL BE TAKEN FORM THE FINISHED CONCRETE CONNECTION.
- SEE SECTION 39, CONSTRUCTION SPECIFICATIONS, "MANHOLES"
- CONE FOR MANHOLES GREATER THAN 60" DIAMETER SHALL BE INDIVIDUALLY DESIGNED.

FLAT SLAB SHALL BE USED WHEN DEPTH DOES NOT PERMIT USE OF TAPER UNIT

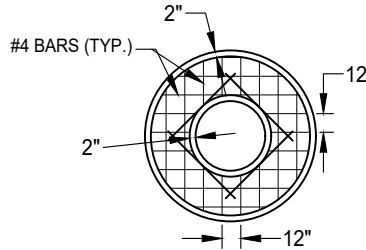
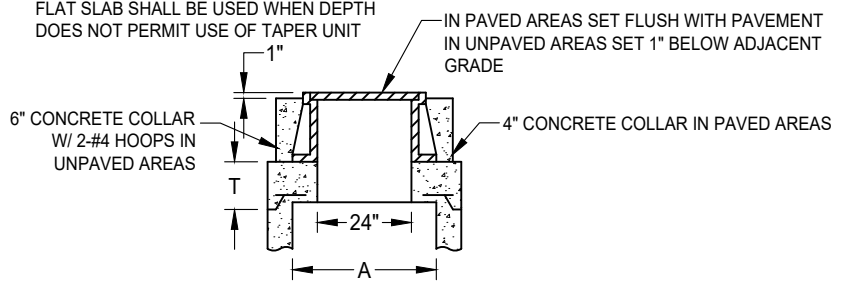

FLAT SLAB TOP

DATE: 09/22/2017		NOT TO SCALE	
REVISION	BY	APPROVED	DATE
1	SJB	SMA	04-12-2024
2	SJB	SMA	02-27-2025

CITY OF ELK GROVE - PUBLIC WORKS

STANDARD PRECAST CONCRETE DRAINAGE MANHOLE

APPROVED BY:  03-12-2025
CITY ENGINEER DATE

DRAWING NUMBER
SD - 7.0



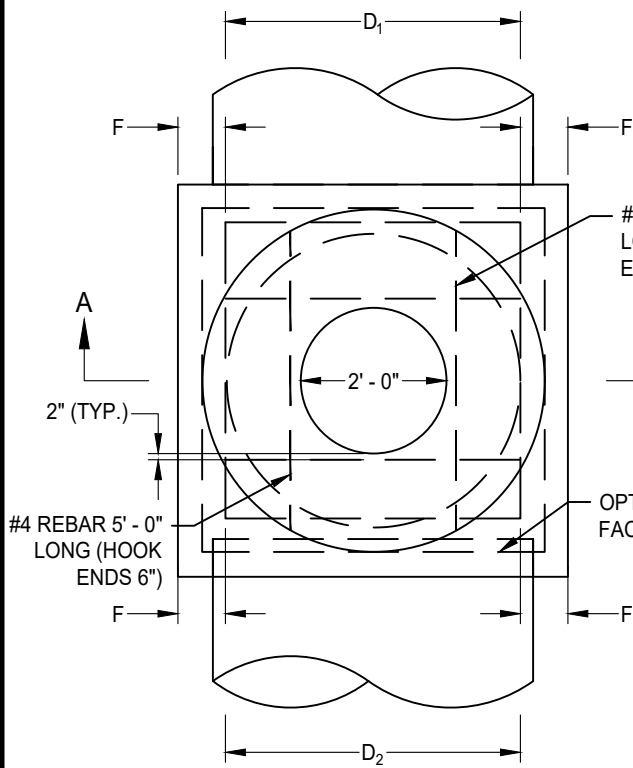

PLAN

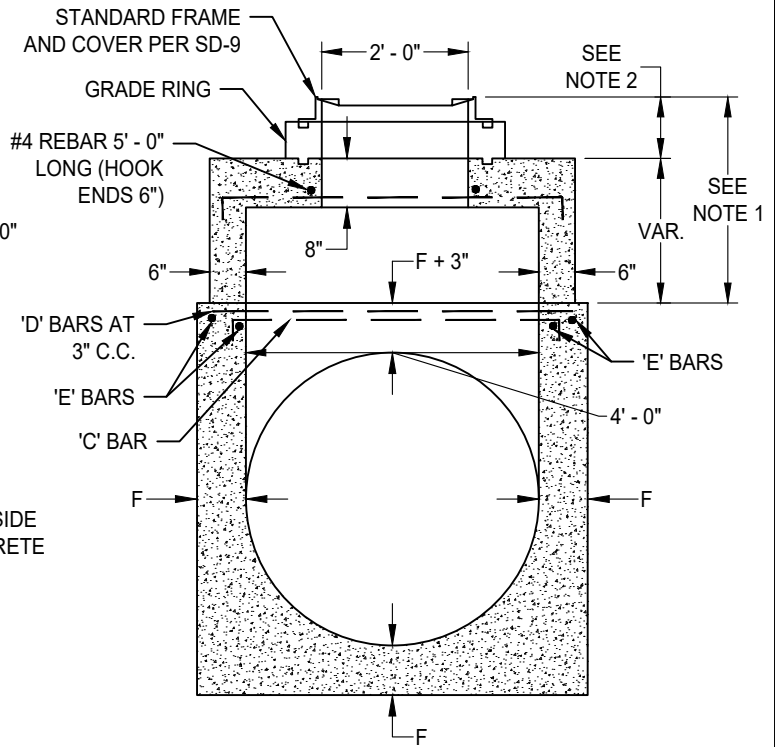

SECTION A-A

NOTES:

1. WHEN DEPTH OF MANHOLE FROM STREET G RADE TO TOP OF BOX IS LESS THAN 2' - 10.5", CONSTRUCT MONOLITHIC SHAFT AS SHOWN. THE CONTRACTOR SHALL HAVE THE OPTION OF CONSTRUCTING SHAFT AS SHOWN FOR ANY DEPTH OF MANHOLE.
2. PER SECTION A - A , MAXIMUM HEIGHT SHALL BE 10.5" AND MINIMUM HEIGHT 7.5".

REINFORCING STEEL FOR M.H. BOX

D ₂	'C' BAR HOOK ENDS 6"			'D' BAR			'E' BAR		
	DIA.	NO.REQ'D	SIZE	LENGTH	NO.REQ'D	SIZE	LENGTH	NO.REQ'D	SIZE
36"	2	# 4	6'-4"	4	# 4	4'-6"	2	# 4	5'-2"
39"	2	# 4	6'-4"	4	# 4	4'-7"	2	# 4	5'-2"
42"	2	# 4	6'-4"	4	# 5	4'-7½"	2	# 4	5'-2"
45"	2	# 4	6'-4"	4	# 5	4'-8½"	2	# 4	5'-2"
48"	2	# 4	6'-4"	4	# 5	5'-0"	4	# 4	5'-2"
51"	2	# 4	6'-4"	4	# 5	5'-4"	4	# 4	5'-2"
54"	2	# 4	6'-4"	4	# 5	5'-8"	4	# 4	5'-2"
57"	2	# 4	6'-4"	4	# 5	5'-11½"	4	# 4	5'-2"
60"	2	# 4	6'-4"	4	# 5	6'-3"	4	# 4	5'-2"
63"	2	# 4	6'-4"	4	# 5	6'-7"	4	# 4	5'-2"
66"	2	# 4	6'-4"	4	# 5	6'-10½"	4	# 4	5'-2"
69"	2	# 4	6'-4"	4	# 5	7'-2½"	4	# 4	5'-2"
72"	2	# 4	6'-4"	4	# 5	7'-6"	4	# 4	5'-2"
78"	2	# 4	6'-4"	4	# 5	8'-1½"	4	# 4	5'-2"
84"	2	# 4	6'-4"	4	# 5	8'-9"	4	# 4	5'-2"
90"	2	# 4	6'-4"	4	# 6	9'-4½"	4	# 4	5'-2"
96"	2	# 4	6'-4"	4	# 6	10'-0"	4	# 4	5'-2"

DATE 03/12/2025		NOT TO SCALE	
REVISION	BY	APPROVED	DATE

CITY OF ELK GROVE - PUBLIC WORKS

**CAST-IN-PLACE CONCRETE
DRAINAGE MANHOLE**

APPROVED BY:

03-12-2025
CITY ENGINEER DATE



DRAWING NUMBER

SD - 7.2

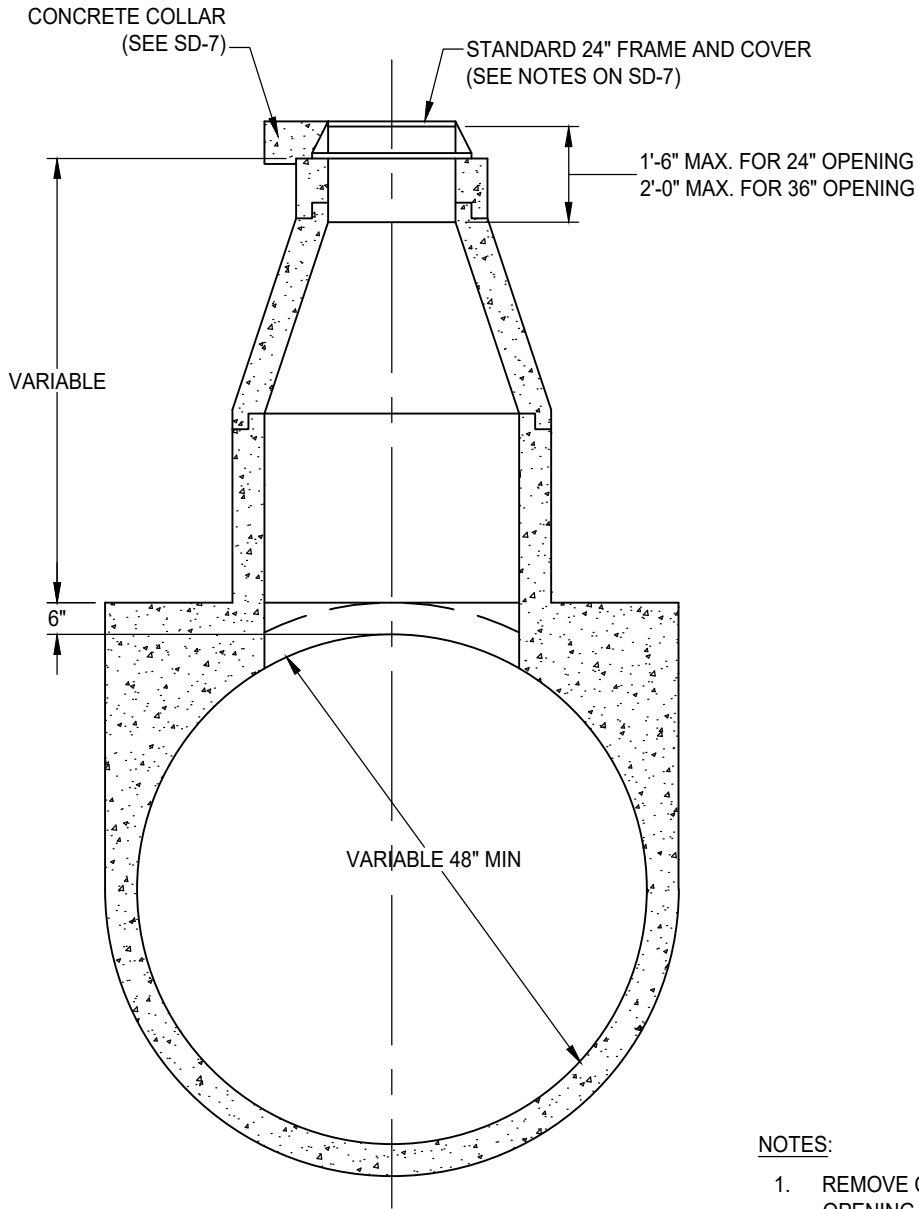

TYPE A
CAST-IN-PLACE PIPE ONLY

NOTES:

1. REMOVE CONCRETE IN MANHOLE OPENING AND CONSTRUCT RISER BASE WHILE CONCRETE IS STILL WORKABLE.
2. PLACE RISER SECTION AFTER CONCRETE HAS SET.
3. SEE SECTION 39, "MANHOLES," AND SECTION 36, CAST-IN-PLACE CONCRETE PIPE.

DATE: 09/22/2017		NOT TO SCALE	
REVISION	BY	APPROVED	DATE

CITY OF ELK GROVE - PUBLIC WORKS

APPROVED BY:

Paul Murock

10/24/2018

CITY ENGINEER

DATE

TYPE A
SADDLE MANHOLE



DRAWING NUMBER

SD - 8A

CONCRETE COLLAR
(SEE STD DWG SD-7)

STANDARD 24" FRAME AND COVER
(SEE NOTES ON STD DWG SD-7)

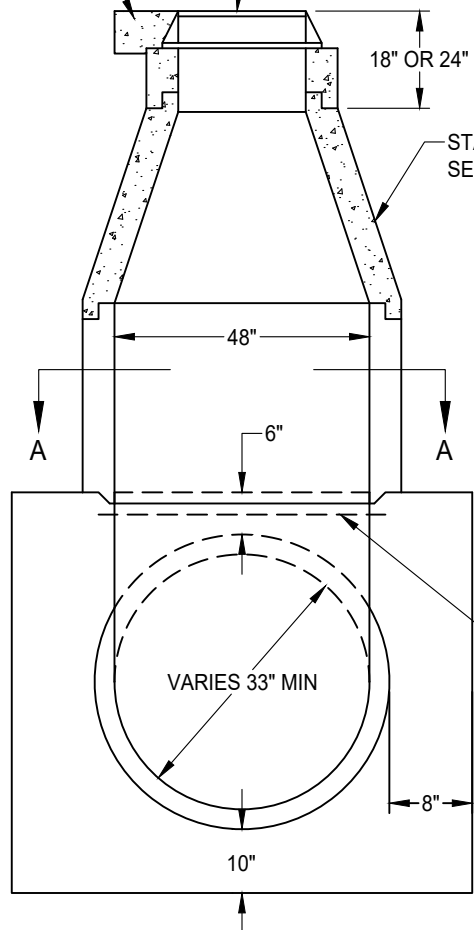

TYPE B

STANDARD MANHOLE SECTION

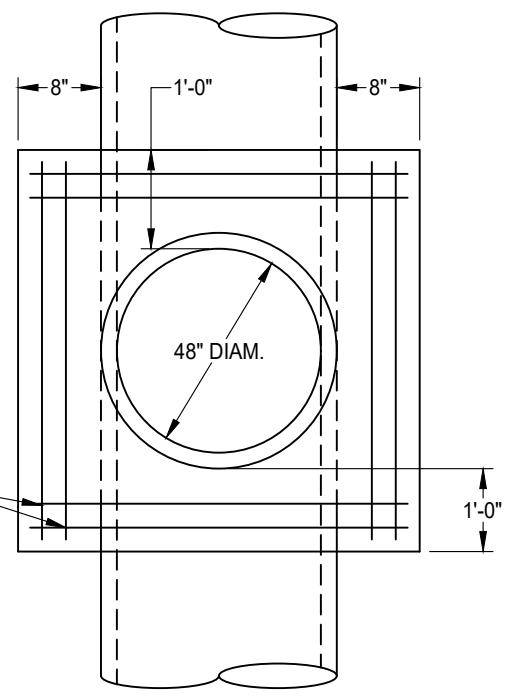

SECTION A-A

2 #5 BARS
EACH WAY

NOTES:

1. CONCRETE SHALL BE CLASS "A" IN CONFORMANCE WITH ARTICLE 50-5 "PORTLAND CEMENT CONCRETE."
2. SEE SECTION 39, "MANHOLES."

DATE: 09/22/2017		NOT TO SCALE	
REVISION	BY	APPROVED	DATE
1	SJB	SMA	04-12-2024

CITY OF ELK GROVE - PUBLIC WORKS

**TYPE B
SADDLE MANHOLE**

APPROVED BY:

CITY ENGINEER

05-28-2024
DATE

DRAWING NUMBER
SD - 8B

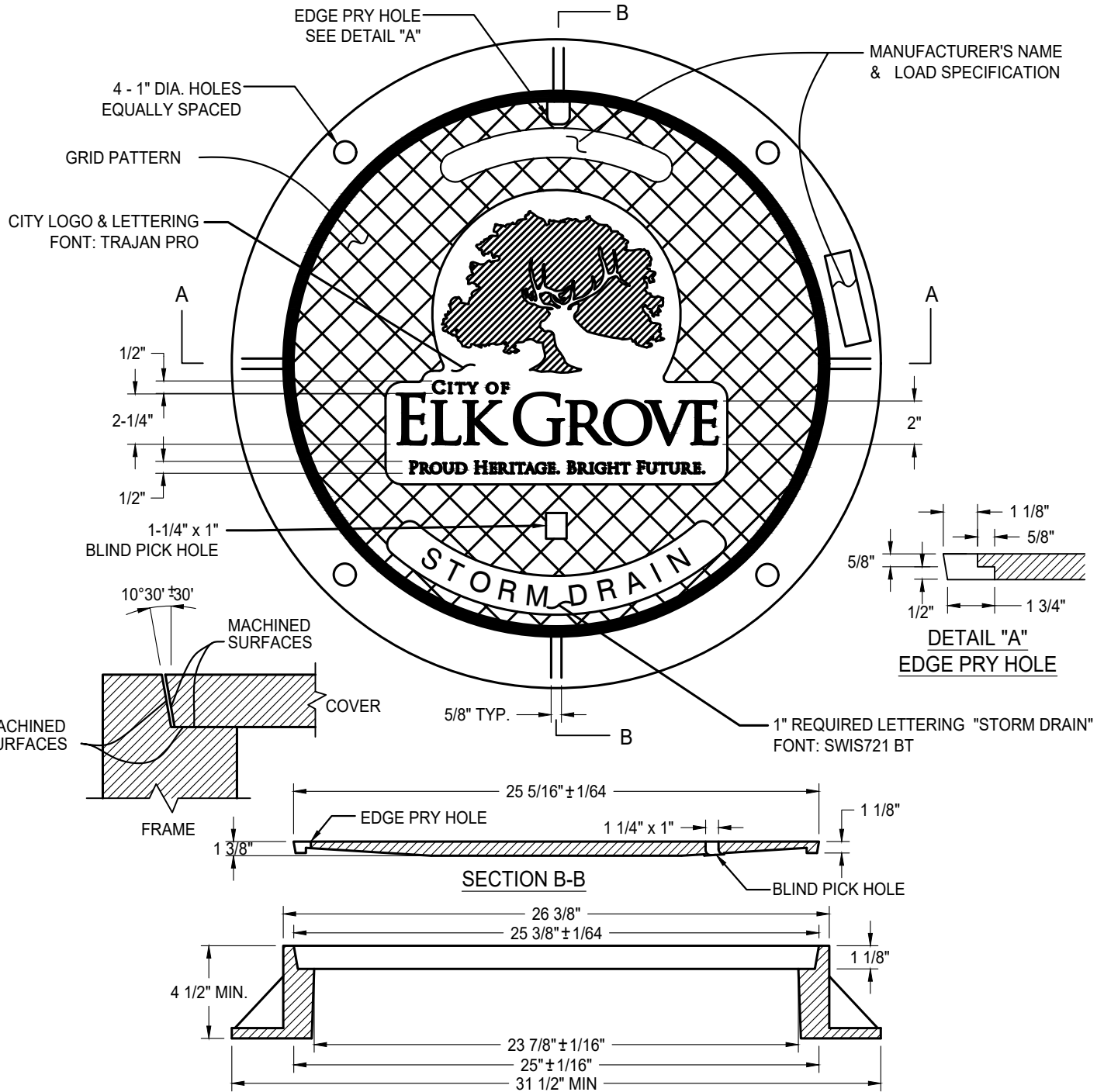



NOTES:

1. ALL CASTINGS TO CONFORM TO ASTM A48, CLASS 35B. CONTACT CITY OF ELK GROVE FOR IMAGE FILE.
2. FRAME AND COVER TO MEET AASHTO M-306-10 LOAD SPECIFICATIONS & MANUFACTURER'S PERFORMANCE REQUIREMENTS FOR POSITION & FIT.
3. FRAME AND COVER SHALL HAVE A COATING OF BLACK BITUMINOUS MATERIAL.
4. A TAMPER RESISTANT BOLTED TYPE FRAME & COVER SHALL BE USED IN EASEMENT AREAS UNLESS OTHERWISE APPROVED.

APPROX. SET WEIGHT	
FRAME	163 LBS
COVER	135 LBS
TOTAL	298 LBS

DATE 12/26/2018		NOT TO SCALE	
REVISION	BY	APPROVED	DATE
01	STN	JRW	02/16/2021

CITY OF ELK GROVE - PUBLIC WORKS

**GREY CAST IRON
STANDARD 24" MANHOLE
FRAME & COVER WITH CITY LOGO**

APPROVED BY:
Paul Muddock 02/26/2021
CITY ENGINEER DATE

DRAWING NUMBER
SD - 9



SET WEIGHT	
FRAME	334 LBS
COVER	197 LBS
TOTAL	531 LBS

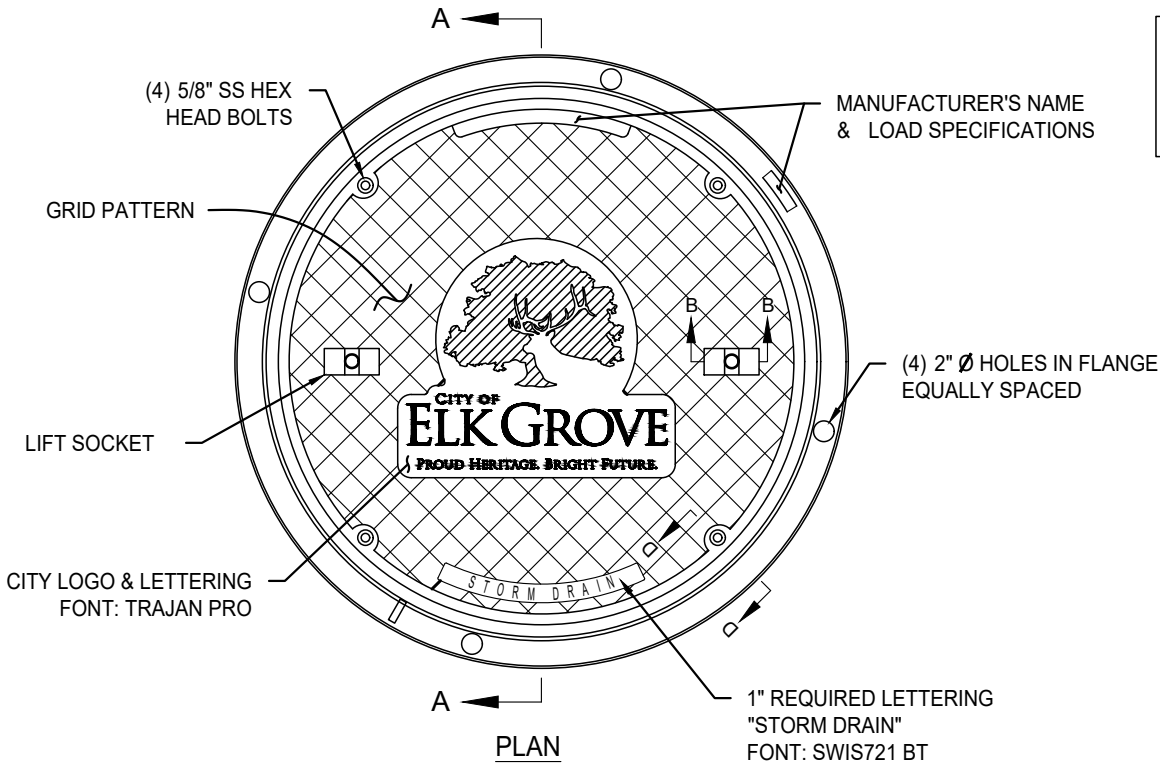

PLAN

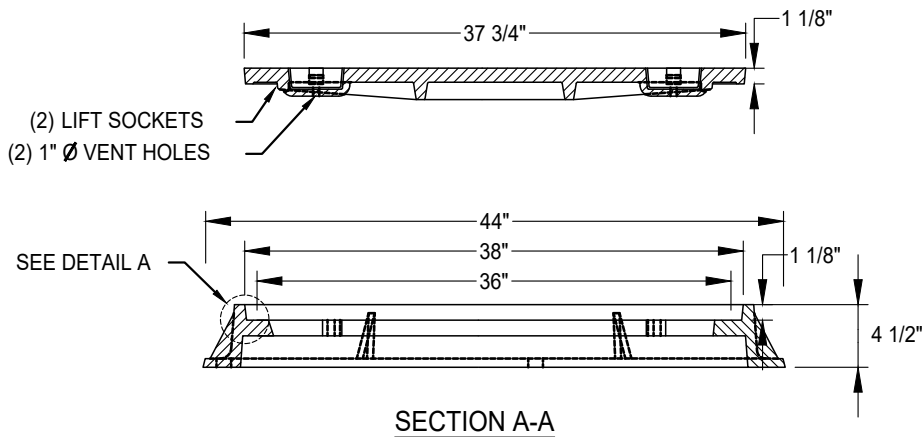

SECTION A-A

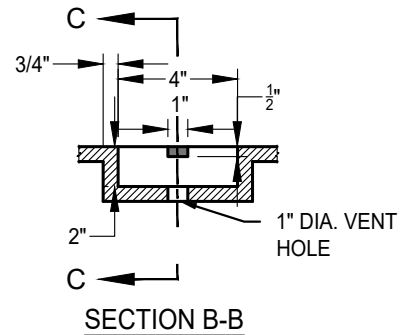

SECTION B-B

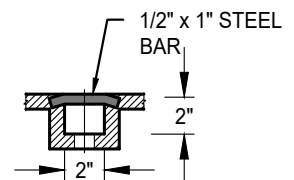

SECTION C-C

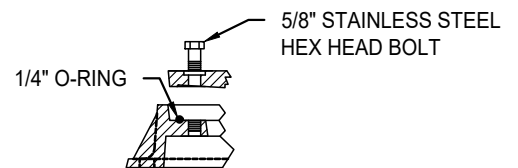

SECTION D-D

NOTES:

1. ALL CASTINGS TO CONFORM TO ASTM A48, CLASS 35B.
2. FRAME AND COVER TO MEET H-20 LOAD SPECIFICATIONS.
3. MACHINED HORIZONTAL AND VERTICAL BEARING SURFACES NOT TO EXCEED 1/64" TOLERANCE.
4. FRAME AND COVER SHALL HAVE A COATING OF BLACK BITUMINOUS PAINT.
5. LOCKING COVER TYPE FRAME AND COVERS SHALL BE USED WHEN SPECIFIED IN CONTRACT DOCUMENTS.
6. H20 RATED SLOTTED GRATE OR GRATE TYPE MANHOLE COVER MAY BE SUBSTITUTE FOR COVER WHEN SPECIFIED IN CONTRACT DOCUMENTS OR UPON APPROVAL OF DIRECTOR.
7. COVER SHALL BE "STORM DRAIN" STAMPED.

DATE XXXX		NOT TO SCALE	
REVISION	BY	APPROVED	DATE
01	STN	SA	3/27/24

CITY OF ELK GROVE - PUBLIC WORKS

**GREY CAST IRON
STANDARD 36" MANHOLE
FRAME & COVER**

APPROVED BY:
Jeffrey B. Wan 04-19-2024
CITY ENGINEER DATE



DRAWING NUMBER
SD - 10

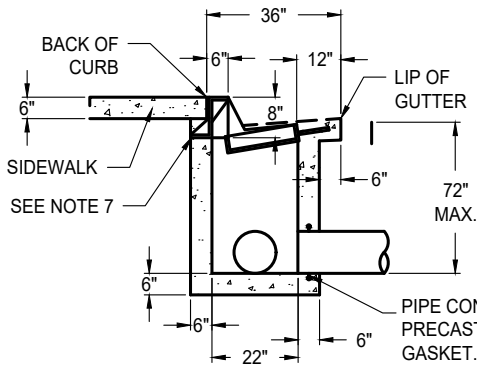
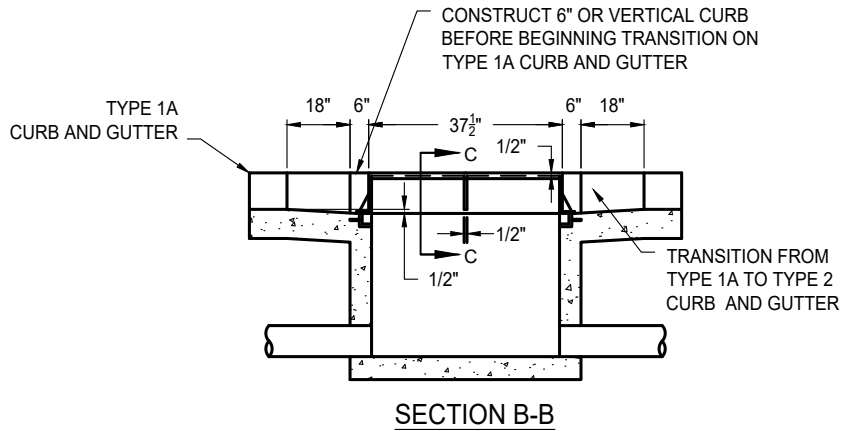
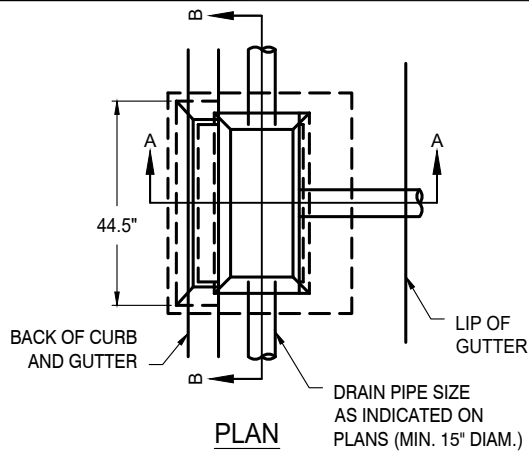

SECTION A-A
TYPE 2 - VERTICAL CURB AND GUTTER

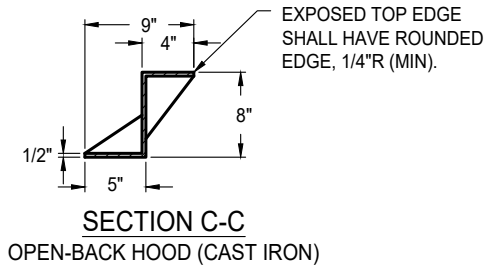

SECTION C-C
OPEN-BACK HOOD (CAST IRON)

PIPE CONNECTIONS SHALL CONFORM TO ASTM C-923. PRECAST UNITS SHALL BE BOOT TYPE OR COMPRESSION GASKET. CAST-IN-PLACE UNITS SHALL INCLUDE A WATER STOP.

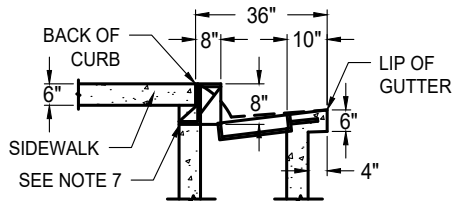

SECTION A-A
TYPE 1A - ROLLED CURB AND GUTTER

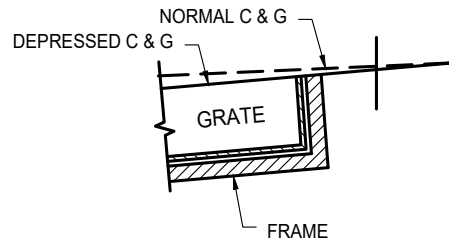

CURB AND GUTTER WITH FRAME

NOTES:

1. STANDARD DEPRESSION FOR INLET IS 1-1/2" AND LIP OF GUTTER MUST BE SET BACK 3" FROM GUTTER FLOW LINE.
2. FRAME AND GRATE SHALL CONFORM TO STANDARD DRAWINGS SD-14 AND SD-15.
3. OPEN-BACK CAST IRON HOOD SHALL BE H-20 RATED, 1/2" THICK, AND REQUIRES NO GALVANIZING.
4. EXPOSED EDGES SHALL HAVE A 1/8" R (MINIMUM).
5. AN EDGING TOOL SHALL BE USED ON ALL EDGES WHERE THE CONCRETE SIDEWALK AND CURB MEET THE TOP OF THE HOOD.
6. EXPOSED SURFACES OF THE GRATES, FRAMES AND HOODS WITH THE PARTS ASSEMBLED AND DISASSEMBLED SHALL BE PAINTED WITH COMMERCIAL QUALITY ASPHALTUM PAINT AFTER TESTING AND ASSEMBLY.
7. SEE SD-12.1 FOR INSTALLATION OF INLETS AT DETACHED SIDEWALKS.
8. WHEN MORE THAN ONE GRATE IS PROPOSED, STD DWG SD-16 FOR SUPPORT ASSEMBLY.

DATE: 09/22/2017		NOT TO SCALE	
REVISION	BY	APPROVED	DATE
01	SJB	SMA	04/4/2025

CITY OF ELK GROVE - PUBLIC WORKS

APPROVED BY:

5-27-2025
CITY ENGINEER DATE

**DROP INLET
TYPE B**

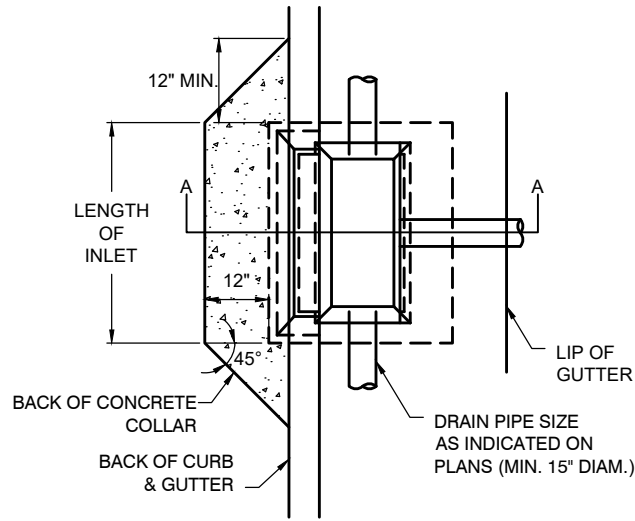

DRAWING NUMBER

SD - 12



PLAN

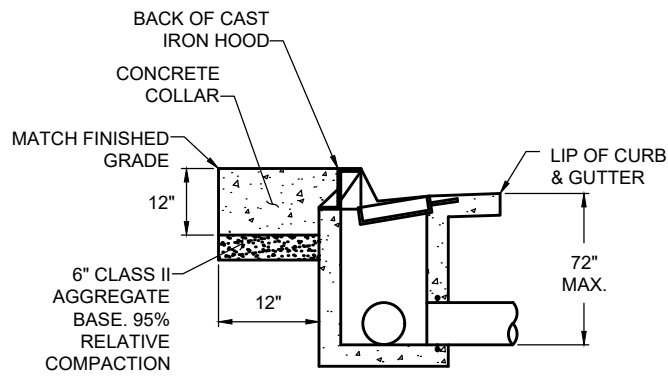

SECTION A-A

NOTES:

1. TO BE USED ON TYPE 1A AND TYPE 2 CURB AND GUTTER WHERE INLETS ARE AT DETACHED SIDEWALKS.

DATE: 09/22/2017		NOT TO SCALE	
REVISION	BY	APPROVED	DATE

CITY OF ELK GROVE - PUBLIC WORKS

**DROP INLET
TYPE B
AT DETACHED SIDEWALK**

APPROVED BY:
Paul Murock
CITY ENGINEER 10/24/2018
DATE



DRAWING NUMBER
SD - 12.1

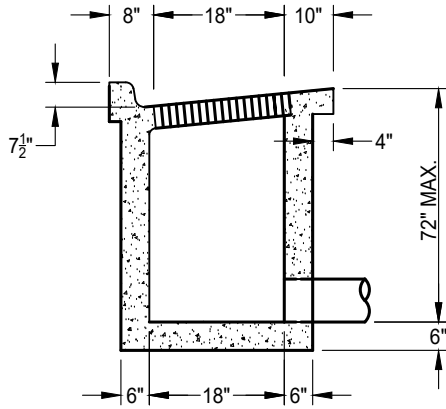

SECTION A-A
TYPE 2 - VERTICAL CURB AND GUTTER

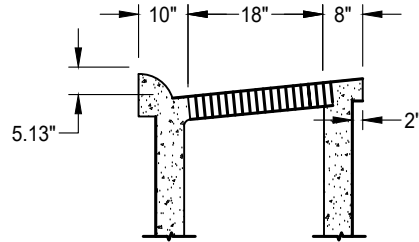

SECTION A-A
TYPE 1A - ROLLED CURB AND GUTTER

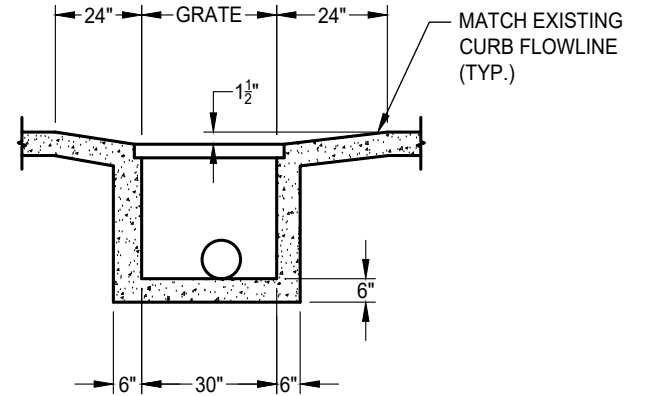

SECTION B-B
STANDARD DEPRESSION

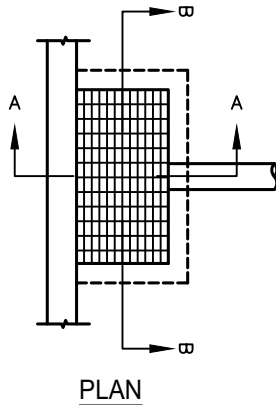

PLAN

NOTES:

1. STANDARD DEPRESSION FOR INLET IS 1-1/2".
2. FRAME AND GRATE SHALL CONFORM TO STANDARD DRAWINGS SD-14 AND SD-15.
3. ALL EXPOSED EDGES SHALL HAVE A 1/8" R (MINIMUM).
4. AN EDGING TOOL SHALL BE USED ON ALL EDGES WHERE THE CONCRETE SIDEWALK AND CURB MEET THE TOP OF THE HOOD.
5. EXPOSED SURFACES OF THE GRATES, FRAMES, AND HOODS WITH THE PARTS ASSEMBLED AND DISASSEMBLED SHALL BE PAINTED WITH COMMERCIAL QUALITY ASPHALTUM PAINT AFTER TESTING AND ASSEMBLY.

DATE 09/22/2007		NOT TO SCALE	
REVISION	BY	APPROVED	DATE
01	BT	JRW	02/16/2021
02	SJB	SMA	04/04/2025

CITY OF ELK GROVE - PUBLIC WORKS

**DROP INLET
TYPE C**

APPROVED BY:

[Signature] 5-27-2025

CITY ENGINEER

DATE



DRAWING NUMBER

SD - 13

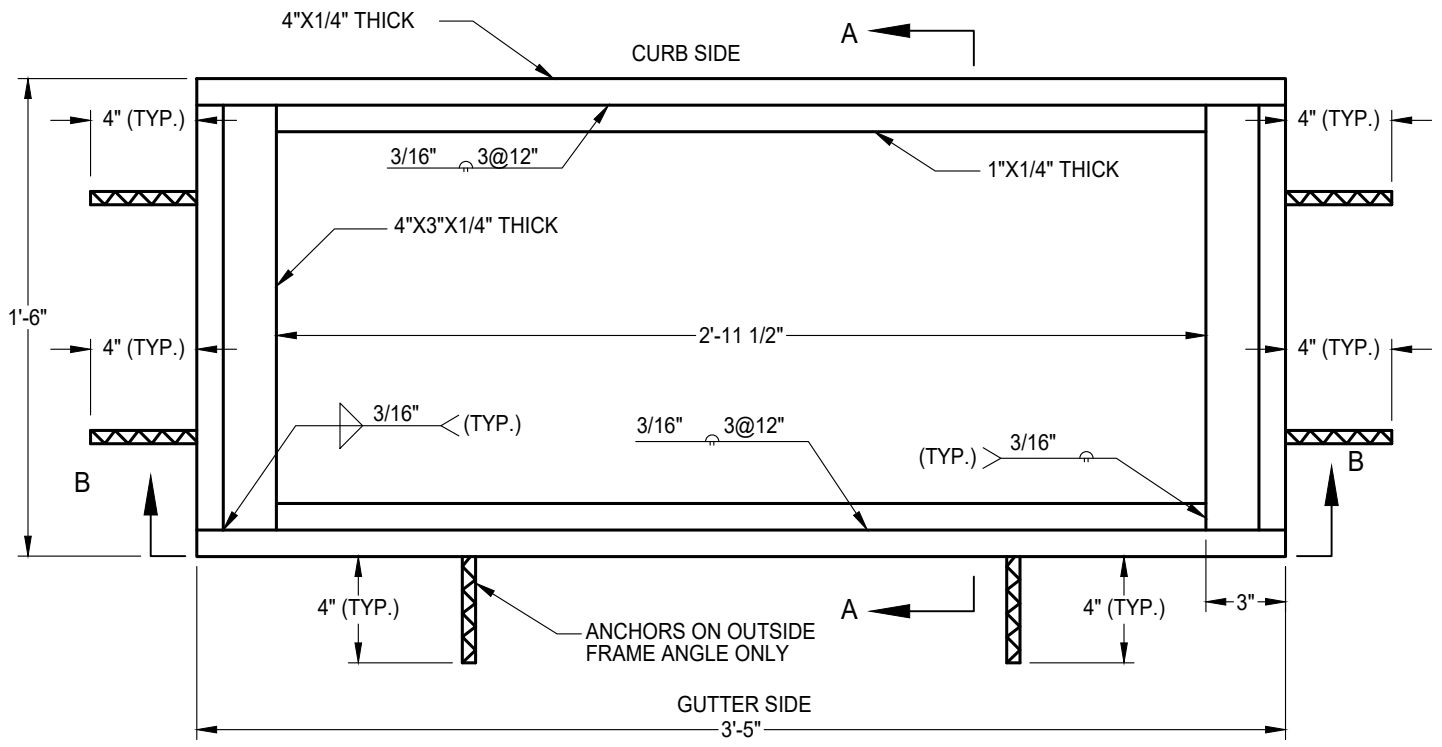

PLAN

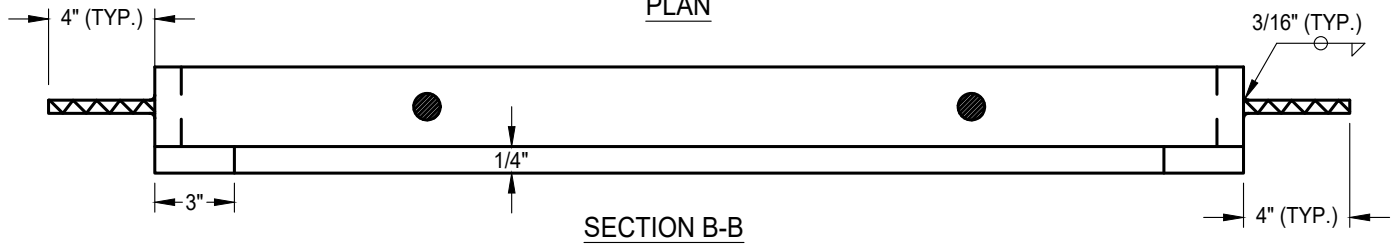

SECTION B-B

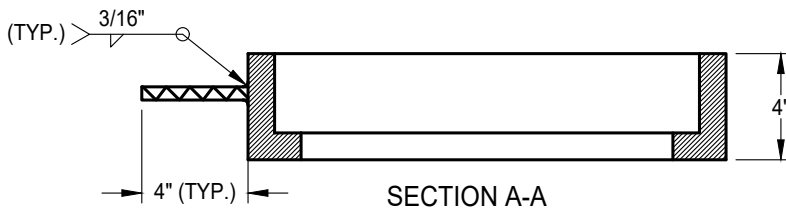

SECTION A-A

NOTES:

1. OMIT 1/2" FRAME ANCHORS OVER CENTER SUPPORT ASSEMBLY WHEN MULTIPLE FRAMES ARE USED.
2. MATERIAL: ASTM A36 MILD STEEL
3. SEE ARTICLE 50-31, "SEWER AND STORM DRAIN CASTINGS," OF SECTION 50.
4. ALL EXPOSED PARTS TO BE HOT DIP GALVANIZED PER ASTM A123, AFTER FABRICATION.

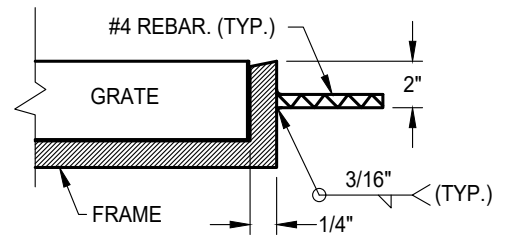

FRAME ANCHOR DETAIL

DATE: 09/22/2017		NOT TO SCALE	
REVISION	BY	APPROVED	DATE

CITY OF ELK GROVE - PUBLIC WORKS

APPROVED BY:

Paul Murbach

10/24/2018

CITY ENGINEER

DATE

WELDED STEEL GRATE FRAME



DRAWING NUMBER

SD - 14

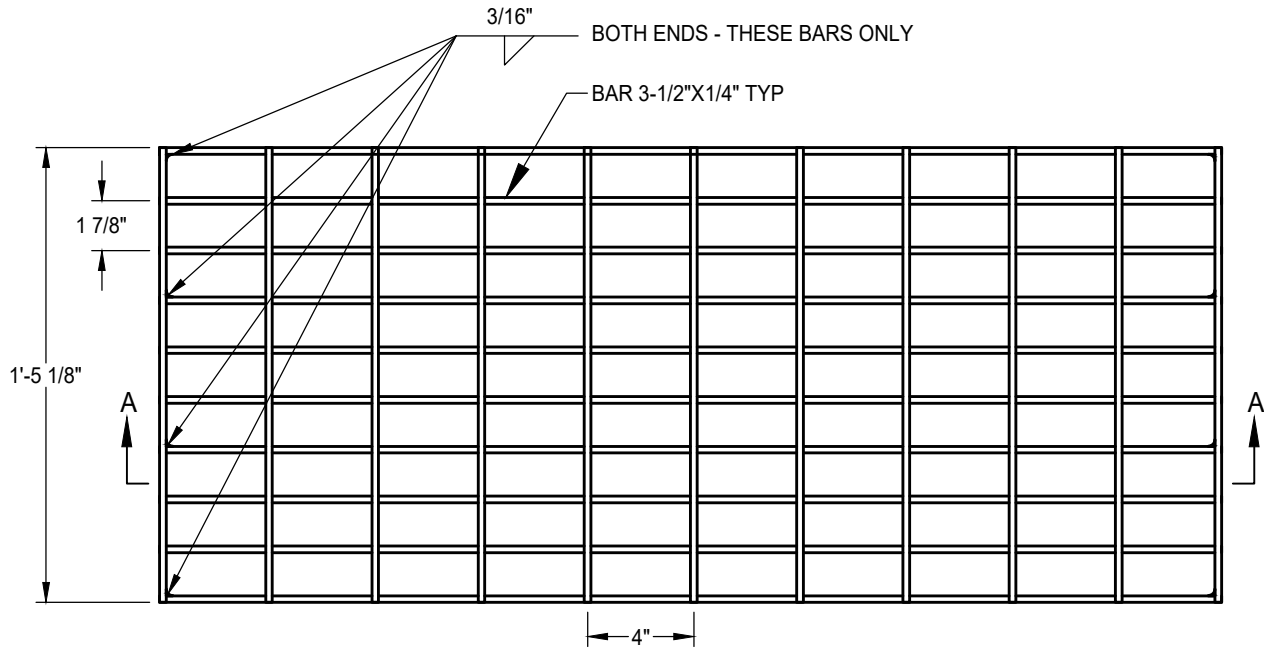

PLAN

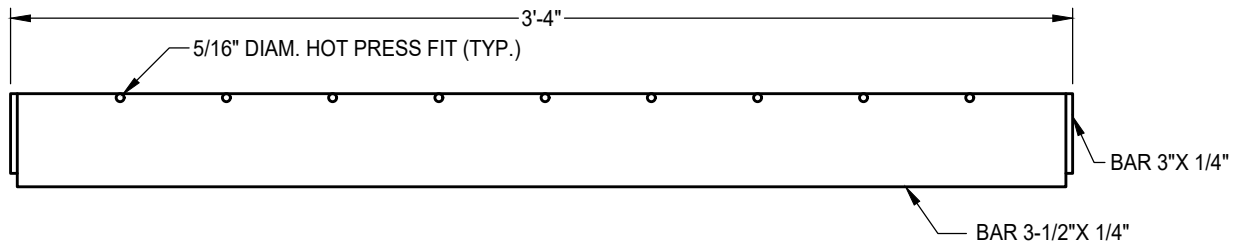

SECTION A-A

NOTES:

1. DIMENSIONS TO CENTERLINE OF BARS UNLESS OTHERWISE NOTED.
2. ALL EXPOSED PARTS TO BE HOT DIP GALVANIZED PER ASTM A123, AFTER FABRICATION.

DATE: 09/22/2017		NOT TO SCALE	
REVISION	BY	APPROVED	DATE

CITY OF ELK GROVE - PUBLIC WORKS

WELDED STEEL GRATE

APPROVED BY:

Paul Murock

CITY ENGINEER

10/24/2018

DATE



DRAWING NUMBER

SD - 15

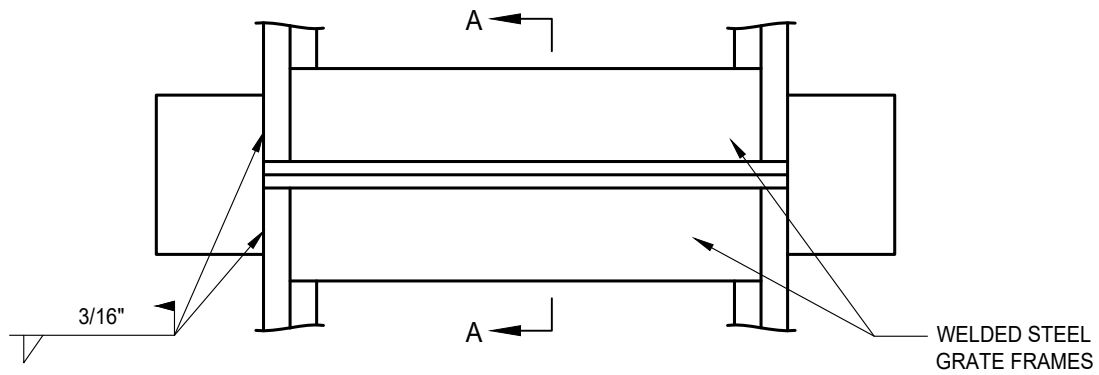

PLAN

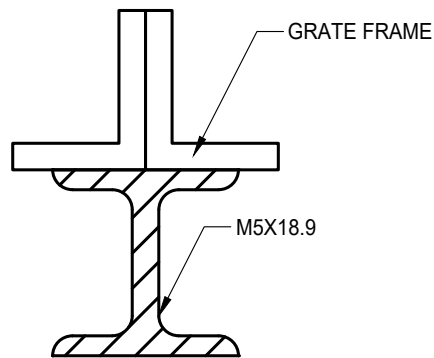

SECTION A-A

NOTES:

1. OMIT 1/2" FRAME ANCHORS OVER CENTER SUPPORT.
2. L=57 INCHES FOR CURB OPENING CATCH BASIN WITH GRATING(S) AND DEBRIS SKIMMER.
3. ALL EXPOSED PARTS TO BE HOT DIP GALVANIZED PER ASTM A123, AFTER FABRICATION.

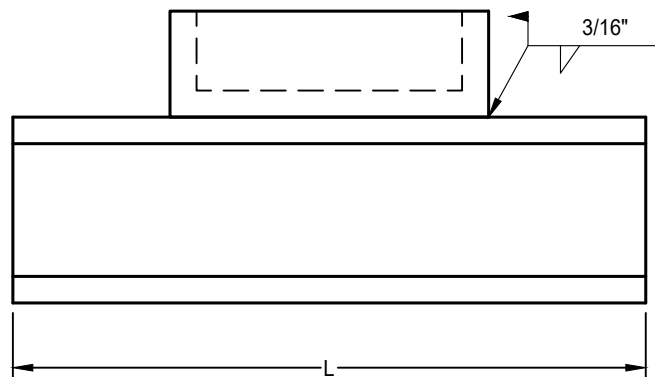

ELEVATION

DATE 09/22/2017		NOT TO SCALE	
REVISION	BY	APPROVED	DATE
01	STN	JRW	02/16/2021

CITY OF ELK GROVE - PUBLIC WORKS

**CENTER SUPPORT ASSEMBLY
FOR MULTIPLE GRATES**

APPROVED BY:

Paul Muroch

CITY ENGINEER

02/17/2021

DATE



DRAWING NUMBER

SD - 16

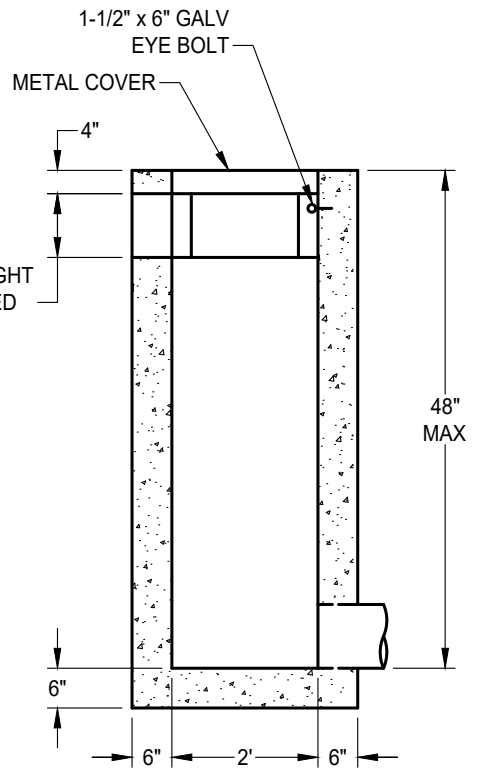
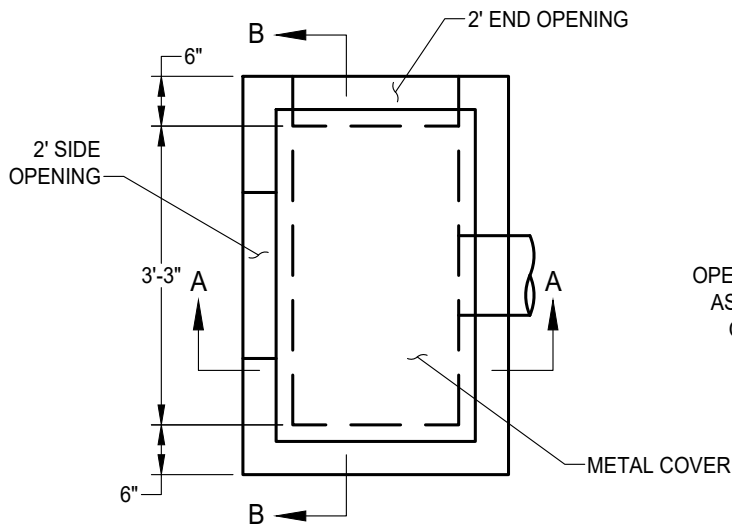

SECTION A-A

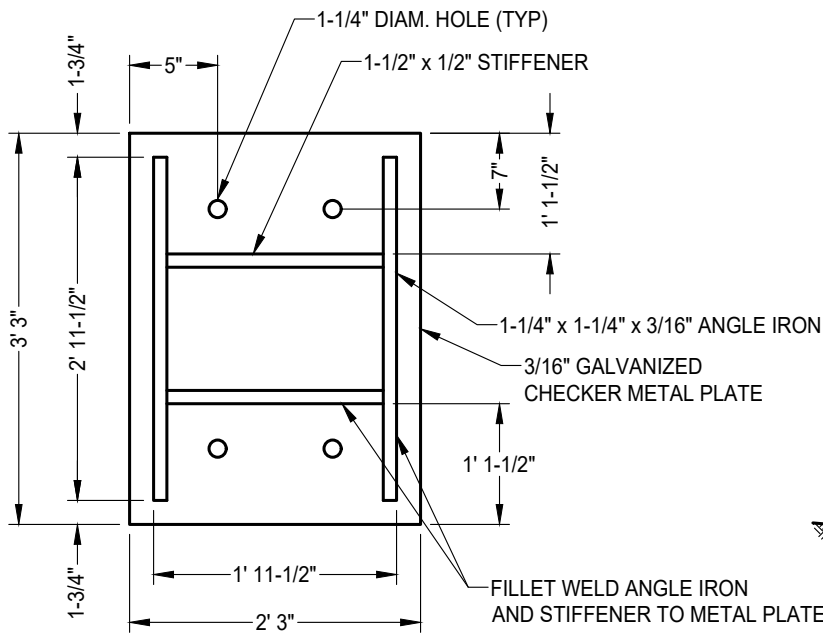

METAL COVER (UNDERSIDE)

PLACE 1/2" DIAM. HORIZONTAL BAR IN CENTER OF SIDE OR END OPENING GREATER THAN 6"

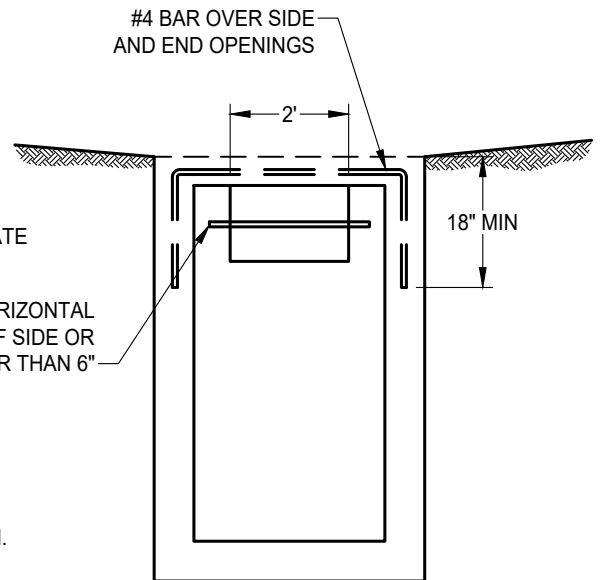

SECTION B-B

NOTES:

1. PROVIDE 1/4" x 18" GALVANIZED CHAIN WELD TO COVER AND EYE BOLT.
2. PROVIDE END OR SIDE OPENINGS AS SHOWN ON PLANS OR CROSS SECTION.
3. TOP OF WALLS TO BE FINISHED TO A FLAT PLANE TO PROVIDE EVEN BEARING FOR PLATE COVER.
4. ALL METALS SHALL BE HOT DIP GALVANIZED PER ASTM A123.

DATE: 09/22/2017		NOT TO SCALE	
REVISION	BY	APPROVED	DATE

CITY OF ELK GROVE - PUBLIC WORKS

**DROP INLET
TYPE F**

APPROVED BY:
Paul Murbach
CITY ENGINEER
10/24/2018
DATE



DRAWING NUMBER
SD - 18

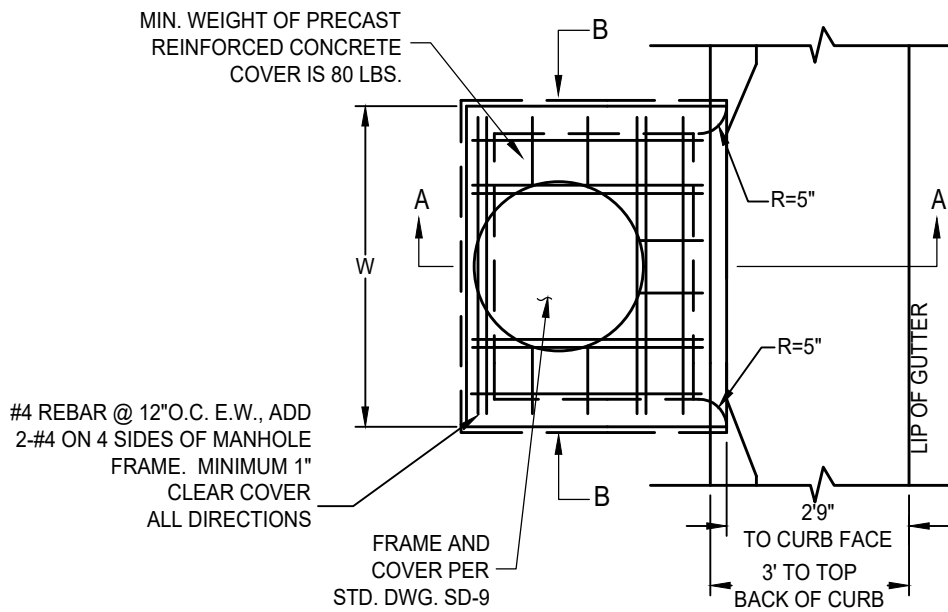

PLAN

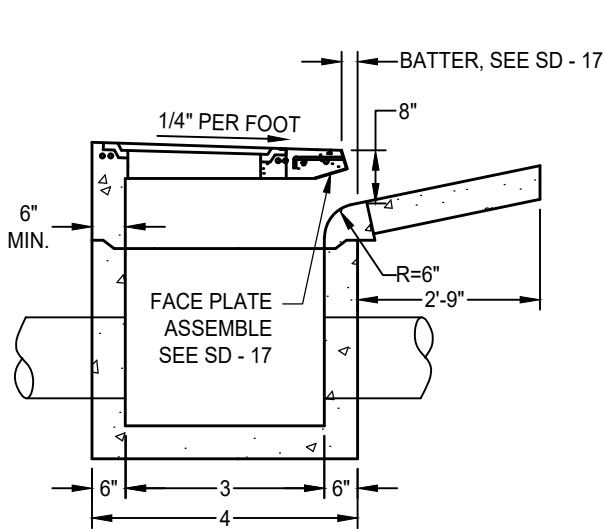

SECTION A-A

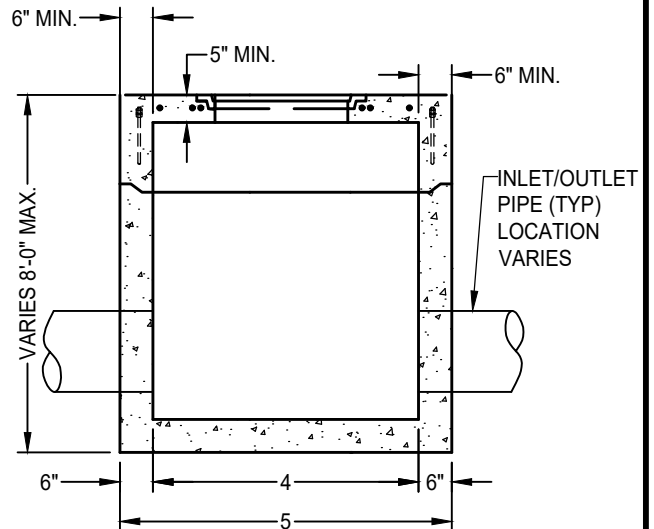

SECTION B-B

NOTES:

1. CURB INLET ASSEMBLY MAY BE PRECAST CONCRETE OR FORMED AND CAST-IN-PLACE P.C.C.
2. ALL METAL SHALL BE HOT DIP GALVANIZED PER ASTM A123.
3. SEE STANDARD DRAWING SD - 17 FOR FACE PLATE ASSEMBLY.

DATE: 09/22/2017		NOT TO SCALE	
REVISION	BY	APPROVED	DATE

CITY OF ELK GROVE - PUBLIC WORKS

APPROVED BY:
Paul Murock
10/24/2018
CITY ENGINEER DATE

**DROP INLET TYPE G
TYPE 2 C&G ONLY
(PG 1 OF 2)**



DRAWING NUMBER
SD - 19.1

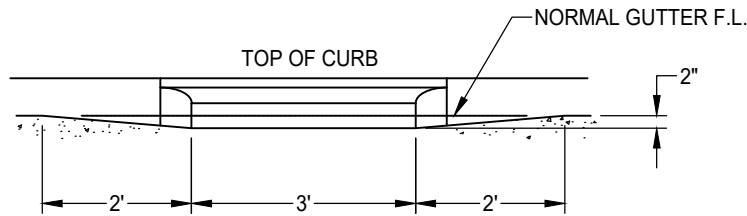

GUTTER TRANSITION ELEVATION

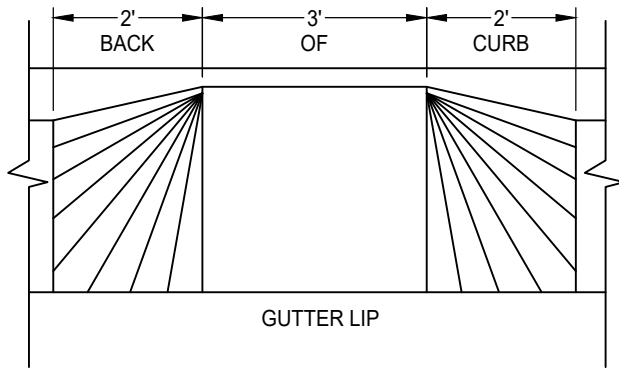
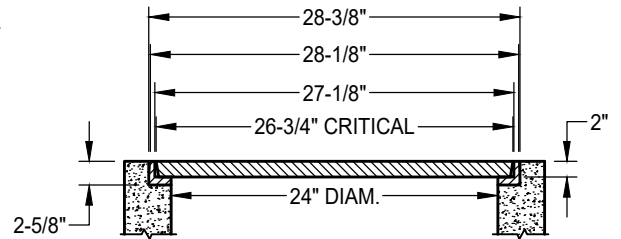

GUTTER TRANSITION PLAN

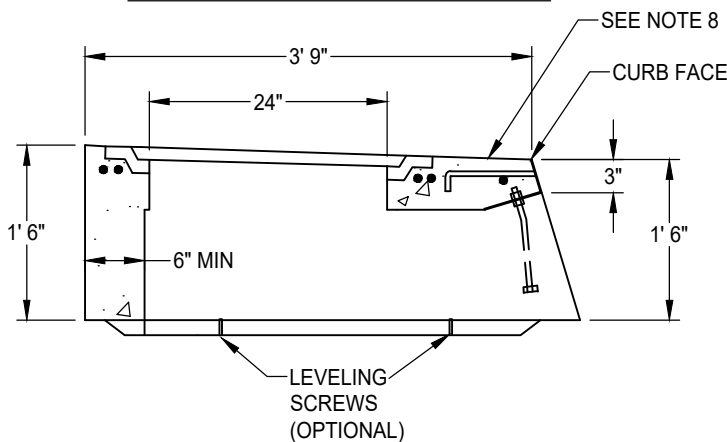
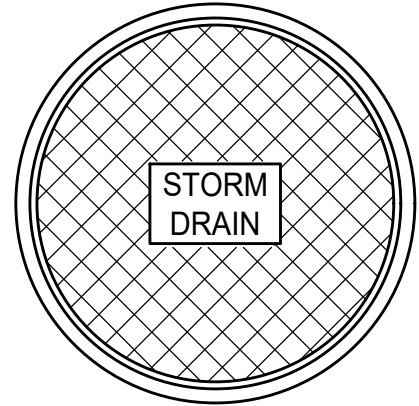

CURB INLET DETAIL

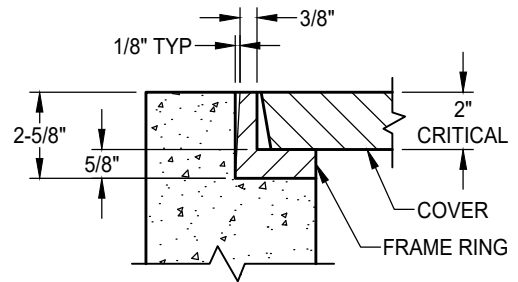

FRAME AND LID DETAIL

WEIGHT	
CAST IRON COVER	91 LBS
CAST IRON FRAME RING	52 LBS

NOTES:

1. CURB INLET ASSEMBLY MAY BE PRECAST CONCRETE, OR FORMED AND CAST-IN-PLACE P.C.C.
2. ALL METAL SHALL BE HOT DIPPED GALVANIZED ASTM A123.
3. ALL CASTINGS TO CONFORM TO ASTM A48, CLASS 35B
4. FRAME AND COVER TO MEET H-20 LOAD SPECIFICATIONS.
5. BEARING SURFACES ARE MACHINE BEVELED TO ASSURE A CLOSE, NON ROCKING SURFACE.
6. FRAME AND COVER SHALL HAVE A COATING OF BLACK BITUMINOUS MATERIAL CONFORMING TO ASTM 48-30.
7. SEE ARTICLE 50-31 "SEWER AND STORM DRAIN CASTINGS" OF SECTION 50, CONSTRUCTION SPECIFICATIONS.
8. INSTALL "NO DUMPING, DRAINS TO CREEK" PLACARD ON TOP OF CURB.

DATE: 09/22/2017		NOT TO SCALE	
REVISION	BY	APPROVED	DATE

CITY OF ELK GROVE - PUBLIC WORKS

**DROP INLET TYPE G
TYPE 2 C&G ONLY
(SHEET 2 OF 2)**

APPROVED BY:
Paul Murock
CITY ENGINEER
10/24/2018
DATE



DRAWING NUMBER
SD - 19.2

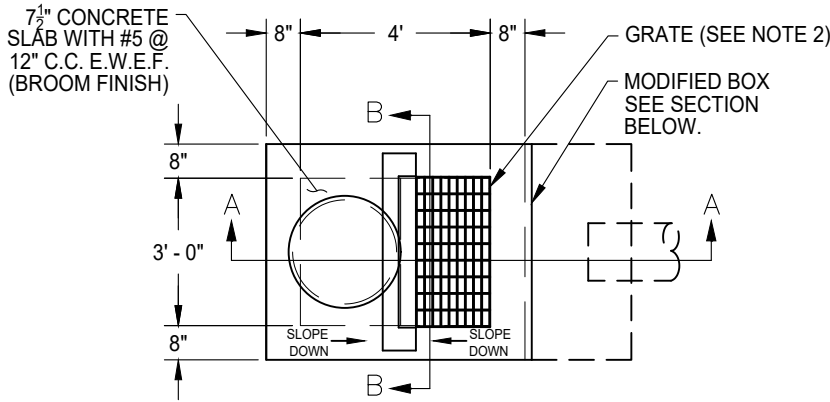

PLAN VIEW

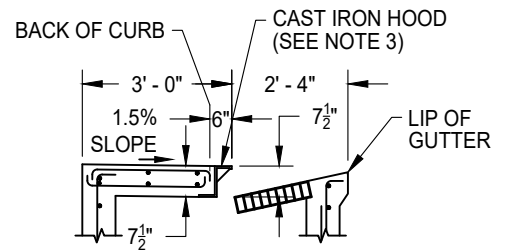

SECTION A-A
TYPE 2 - VERTICAL CURB AND GUTTER
(FOR INFORMATION NOT SHOWN OR NOTED REFER TO SECTION A-A TYPE 1A CURB AND GUTTER)

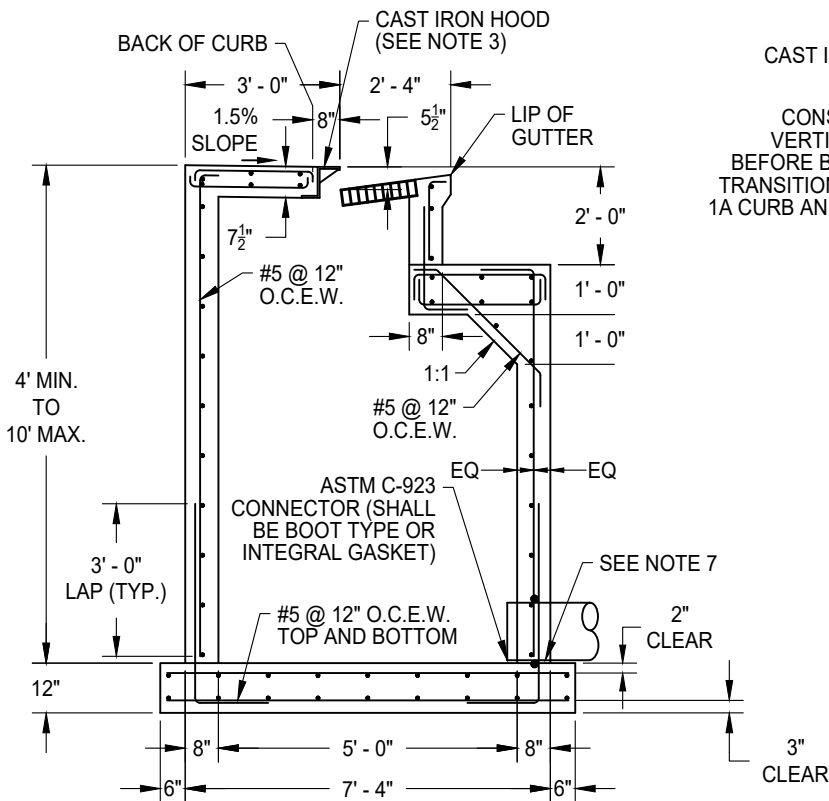

SECTION A-A
TYPE 1A - ROLLED CURB AND GUTTER

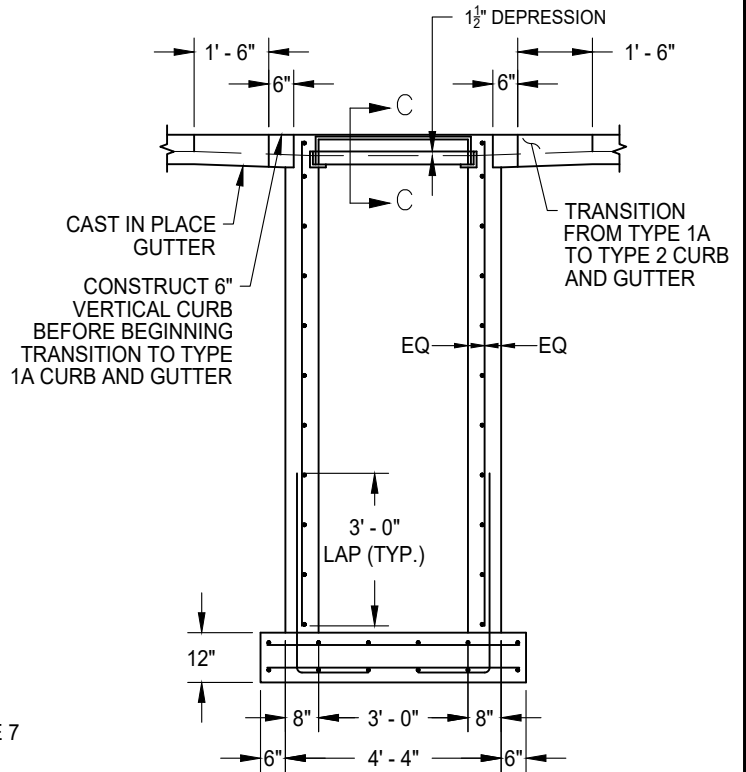

SECTION B-B

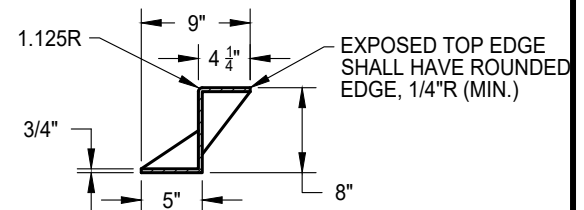

SECTION C-C
OPEN-BACK HOOD (CAST IRON)

- NOTES:**
- STANDARD DEPRESSION FOR INLET IS 1-1/2".
 - FRAME AND GRATE SHALL CONFORM TO STANDARD DRAWINGS SD-14 AND SD-15.
 - OPEN BACK CAST IRON HOOD SHALL BE H-20 RATED, 3/4" THICK, AND REQUIRES NO GALVANIZING.
 - ALL EXPOSED EDGES SHALL HAVE A 1/8" RADIUS (MINIMUM).
 - AN EDGING TOOL SHALL BE USED ON ALL EDGES WHERE THE CONCRETE SIDEWALK AND CURB MEET THE TOP OF THE HOOD.
 - EXPOSED SURFACES OF THE GRATES, FRAMES, AND HOODS WITH THE PARTS ASSEMBLED DISASSEMBLED SHALL BE PAINTED WITH COMMERCIAL QUALITY ASPHALTUM PAINT AFTER TESTING AND ASSEMBLY.
 - THE MINIMUM PIPE SIZE IS 12". IF THE INLET DEPTH IS GREATER THAN 4', THE MINIMUM PIPE SIZE SHALL BE 15".
 - THE MANHOLE FRAME AND COVER SHALL BE PER STANDARD DRAWING SD-9.

DATE: 09/22/2017		NOT TO SCALE	
REVISION	BY	APPROVED	DATE
01	SJB	SMA	04/04/2025

CITY OF ELK GROVE - PUBLIC WORKS

APPROVED BY:

05-27-2025
CITY ENGINEER DATE

MODIFIED TYPE J INLET

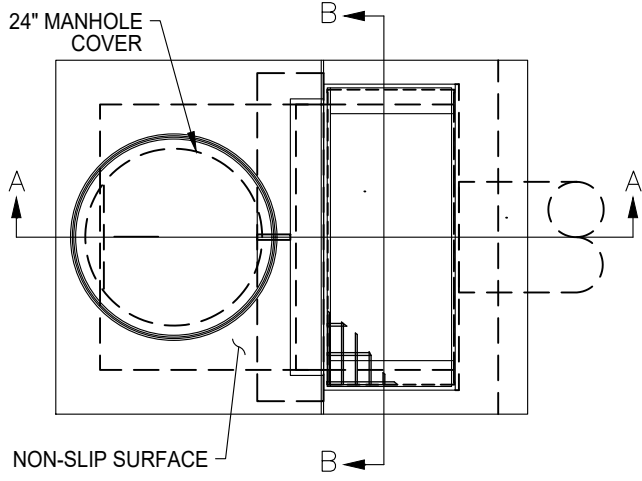

DRAWING NUMBER

SD - 19.3



PLAN VIEW

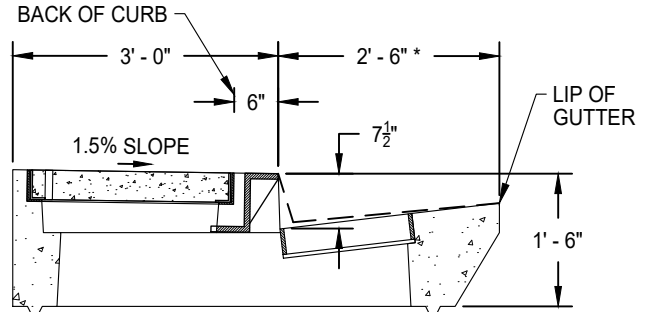

SECTION A-A
TYPE 2 CURB AND GUTTER
(FOR INFORMATION NOT SHOWN OR NOTED REFER TO SECTION A-A TYPE 1A CURB AND GUTTER)

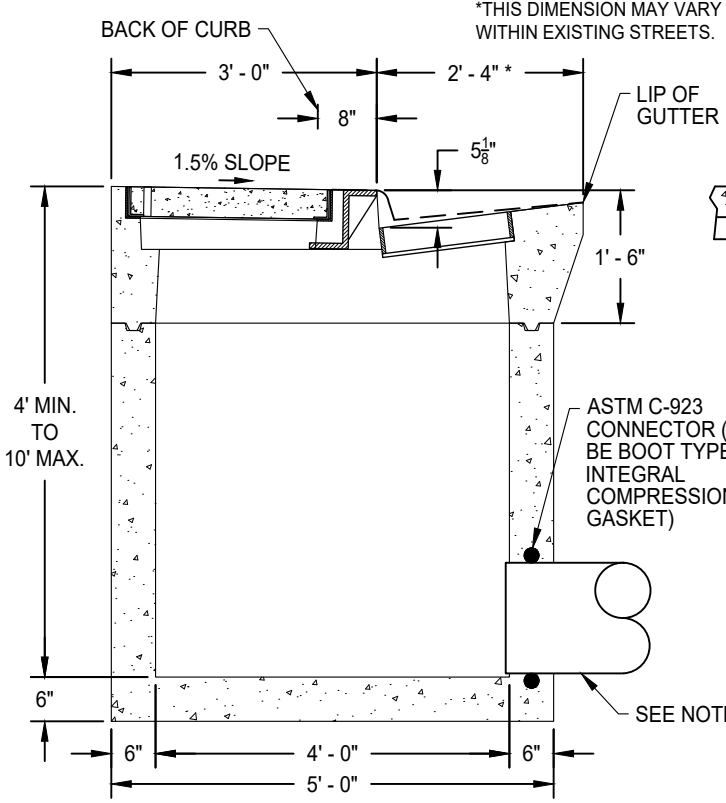

SECTION A-A
TYPE 1A CURB AND GUTTER

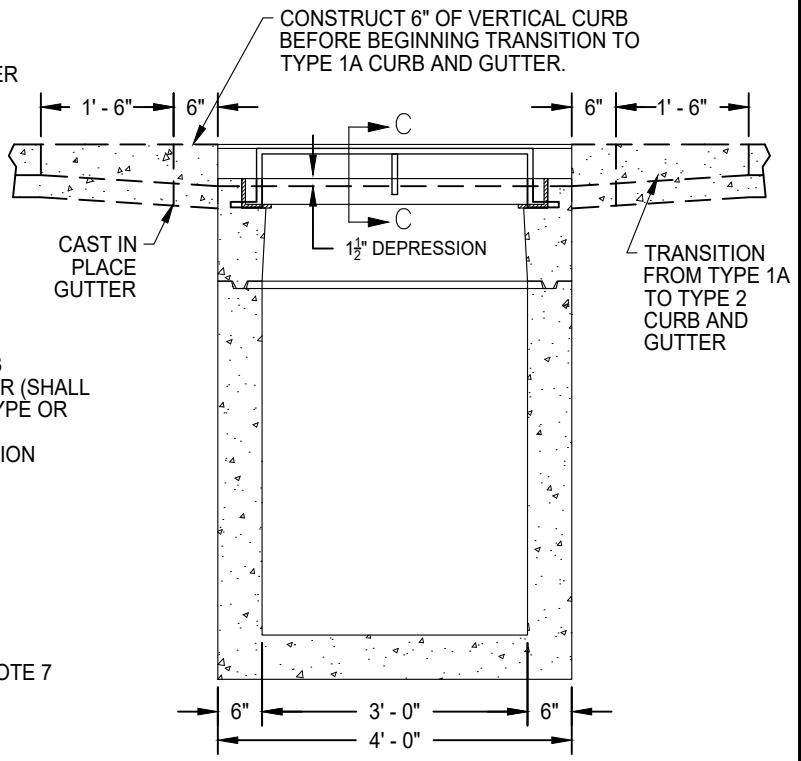

SECTION B-B

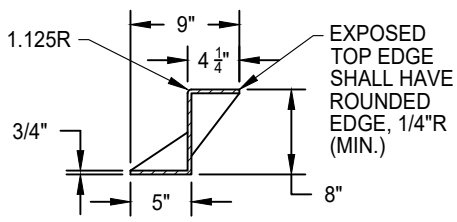

SECTION C-C
OPEN-BACK HOOD (CAST IRON)

NOTES:

1. STANDARD DEPRESSION FOR INLET IS 1-1/2".
2. FRAME AND GRATE SHALL CONFORM TO STANDARD DRAWINGS SD-14 AND SD-15.
3. OPEN BACK CAST IRON HOOD SHALL BE H-20 RATED, 3/4" THICK, AND REQUIRES NO GALVANIZING.
4. ALL EXPOSED EDGES SHALL HAVE A 1/8" RADIUS (MINIMUM).
5. AN EDGING TOOL SHALL BE USED ON ALL EDGES WHERE THE CONCRETE SIDEWALK AND CURB MEET THE TOP OF THE HOOD
6. EXPOSED SURFACES OF THE GRATE, FRAMES AND HOOD WITH THE PARTS ASSEMBLED AND DISASSEMBLED SHALL BE PAINTED WITH COMMERCIAL QUALITY ASPHALTUM PAINT AFTER TESTING AND ASSEMBLY OR GALVANIZED.
7. THE MINIMUM PIPE SIZE IS 12". IF THE INLET DEPTH IS GREATER THAN 4', THE MINIMUM PIPE SIZE SHALL BE 15".
8. THE MANHOLE FRAME AND COVER SHALL BE PER STANDARD DRAWING SD-9.

DATE: 5/27/2025		NOT TO SCALE	
REVISION	BY	APPROVED	DATE

CITY OF ELK GROVE - PUBLIC WORKS

**PRECAST DROP INLET
TYPE J**

APPROVED BY: 

5-27-2025
DATE

CITY ENGINEER

DRAWING NUMBER
SD - 19.4



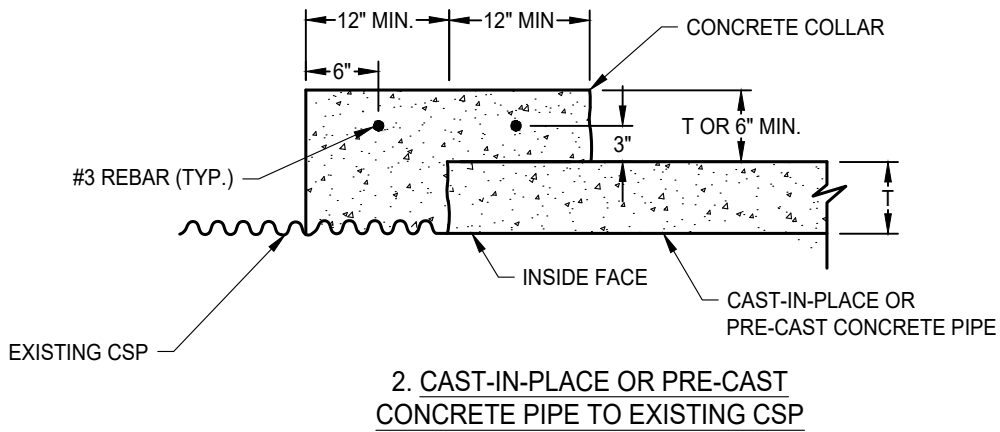
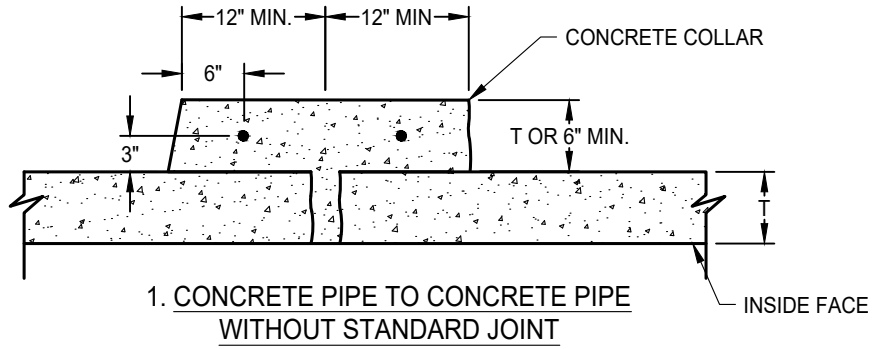

DATE: 09/22/2017		NOT TO SCALE	
REVISION	BY	APPROVED	DATE
1	SJB	SMA	02-28-2024

CITY OF ELK GROVE - PUBLIC WORKS

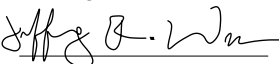
APPROVED BY:

 CITY ENGINEER DATE: 04-29-2024

PIPE CONNECTIONS



DRAWING NUMBER

SD - 23

MANHOLE BASE AND BARREL SECTION. MANHOLE CONE, FRAME, AND COVER OMITTED FOR CLARITY.

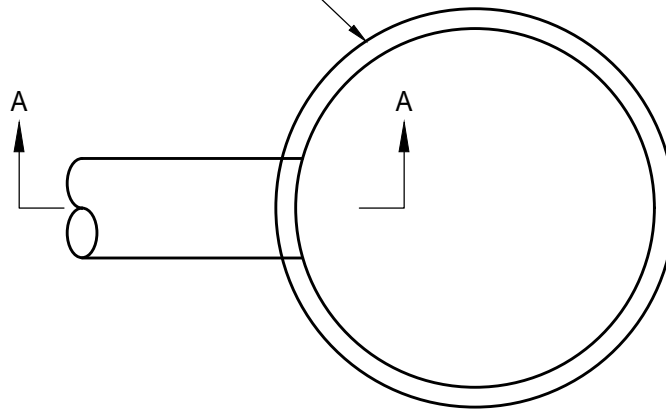

PLAN

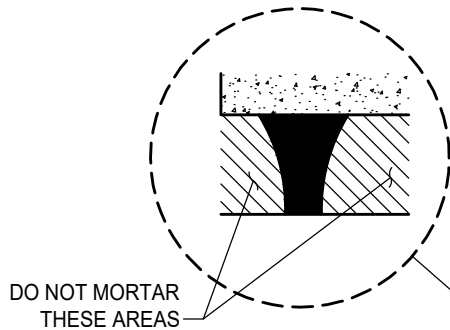

DO NOT MORTAR THESE AREAS

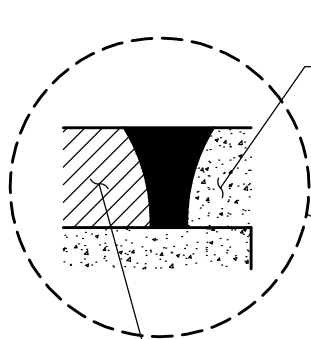

DO NOT MORTAR THIS AREA

MORTAR THIS AREA

DO NOT MORTAR

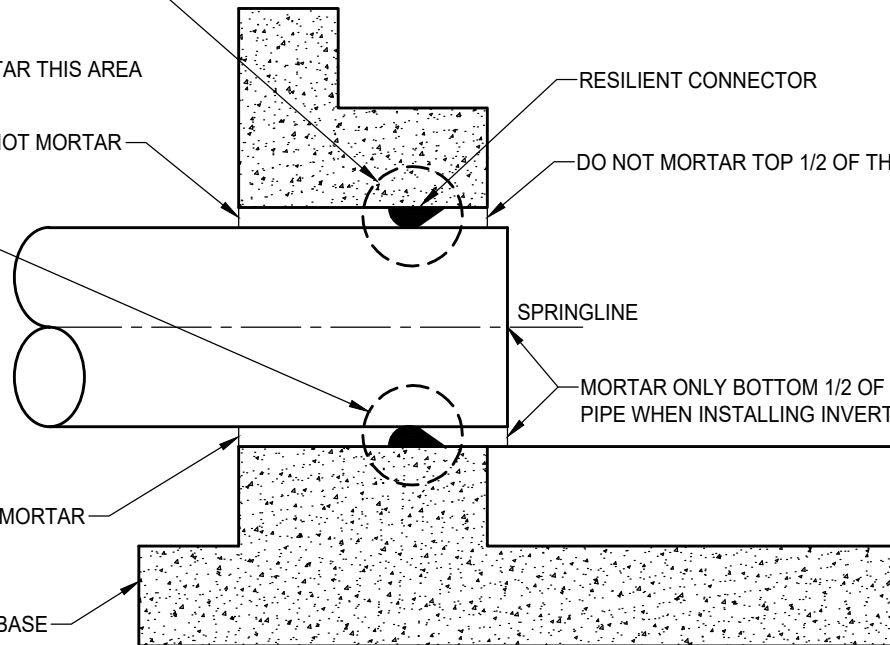

SECTION A-A

NOTES:

1. TO HELP CREATE A FLEXIBLE, WATERTIGHT JOINT, DO NOT PLACE MORTAR AROUND THE CONNECTOR ON THE OUTSIDE OF THE STRUCTURE OR AROUND THE TOP HALF OF THE CONNECTOR ON THE INSIDE WHEN COMPLETING THE INVERT WORK.
2. RESILIENT CONNECTORS SHALL BE A FLEXIBLE COMPRESSION GASKET OR BOOT CONNECTOR PER SECTION 39-2.01 "PRECAST CONCRETE STORM DRAIN MANHOLES" OF THE CITY OF ELK GROVE STANDARD CONSTRUCTION SPECIFICATIONS.
3. ALL CONNECTORS SHALL MEET OR EXCEED THE REQUIREMENTS OF A.S.T.M. C-923.

DATE: 09/22/2017		NOT TO SCALE	
REVISION	BY	APPROVED	DATE

CITY OF ELK GROVE - PUBLIC WORKS

FLEXIBLE PIPE TO MANHOLE CONNECTION

APPROVED BY:

Paul Murock

CITY ENGINEER

10/24/2018

DATE



DRAWING NUMBER

SD - 24

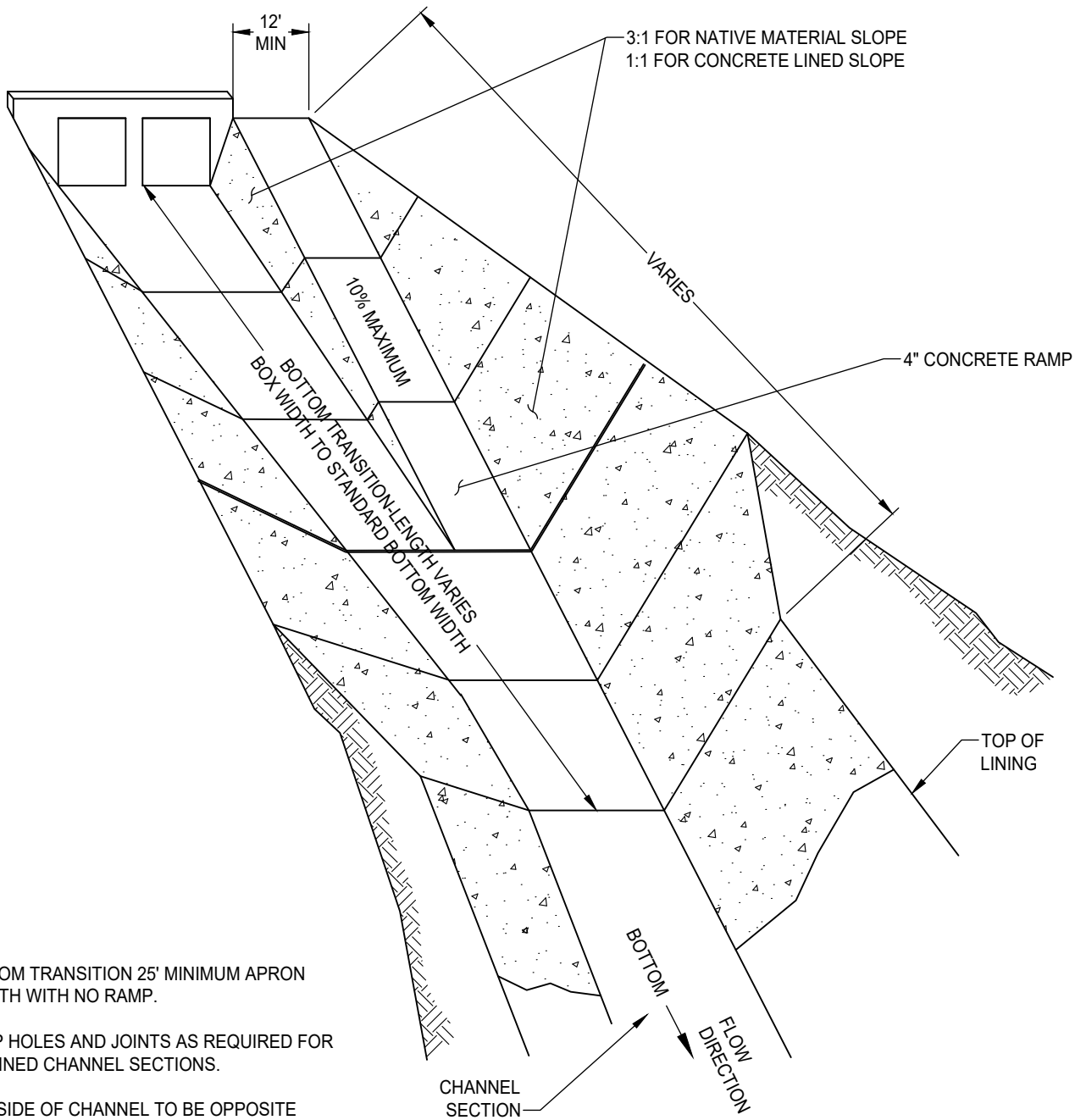

NOTES:

1. BOTTOM TRANSITION 25' MINIMUM APRON LENGTH WITH NO RAMP.
2. WEEP HOLES AND JOINTS AS REQUIRED FOR ALL LINED CHANNEL SECTIONS.
3. LOW SIDE OF CHANNEL TO BE OPPOSITE RAMP.
4. SIDE SLOPE LINING MAY BE USED AT RAMP LOCATIONS TO INCREASE SLOPE TO MAXIMUM 1:1. TOP OF SLOPE GREATER THAN 3:1 MUST BE FENCED.

DATE: 09/22/2017		NOT TO SCALE	
REVISION	BY	APPROVED	DATE

CITY OF ELK GROVE - PUBLIC WORKS

**TYPICAL RAMP AND TRANSITION
DETAIL**

APPROVED BY:

Paul Murock

10/24/2018

CITY ENGINEER

DATE



DRAWING NUMBER

SD - 25

W = 6' 0" MINIMUM
W = 2 x PIPE DIAM. (3'+)

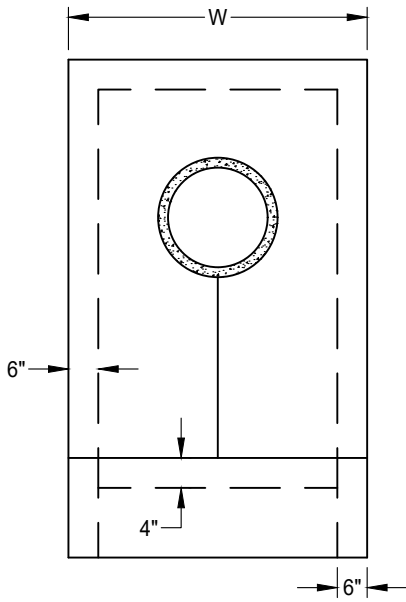

FRONT VIEW

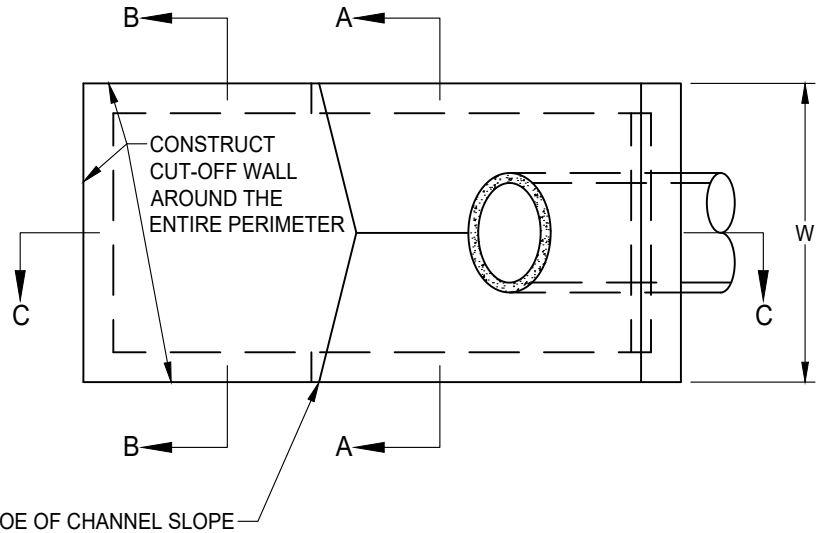

TOP VIEW

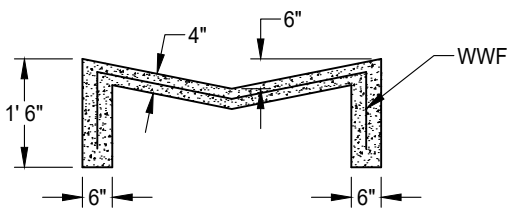

SECTION A-A

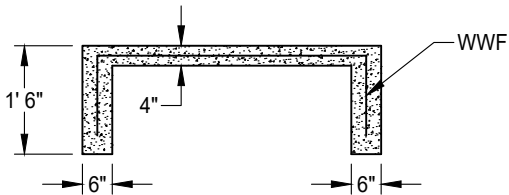

SECTION B-B

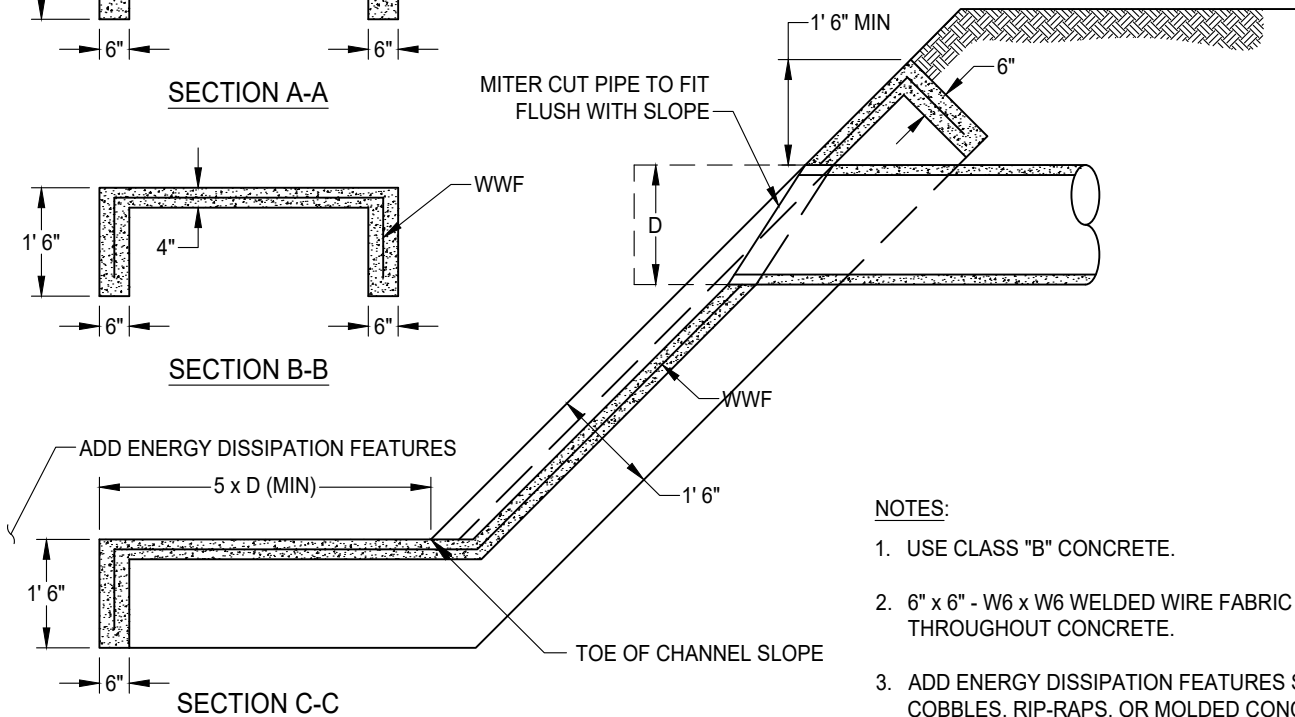

NOTES:

1. USE CLASS "B" CONCRETE.
2. 6" x 6" - W6 x W6 WELDED WIRE FABRIC (WWF) THROUGHOUT CONCRETE.
3. ADD ENERGY DISSIPATION FEATURES SUCH AS COBBLES, RIP-RAPS, OR MOLDED CONCRETE AT END OF APRON.

DATE: 09/22/2017		NOT TO SCALE	
REVISION	BY	APPROVED	DATE

CITY OF ELK GROVE - PUBLIC WORKS

OUTLET PIPE HEADWALL AND APRON

APPROVED BY:
Paul Murbach
CITY ENGINEER 10/24/2018
DATE



DRAWING NUMBER

SD - 26

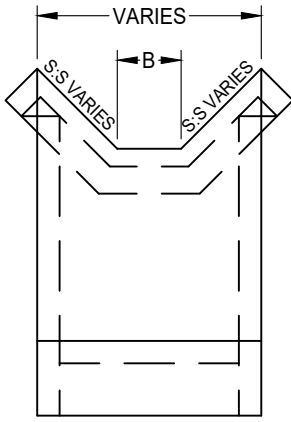

FRONT VIEW

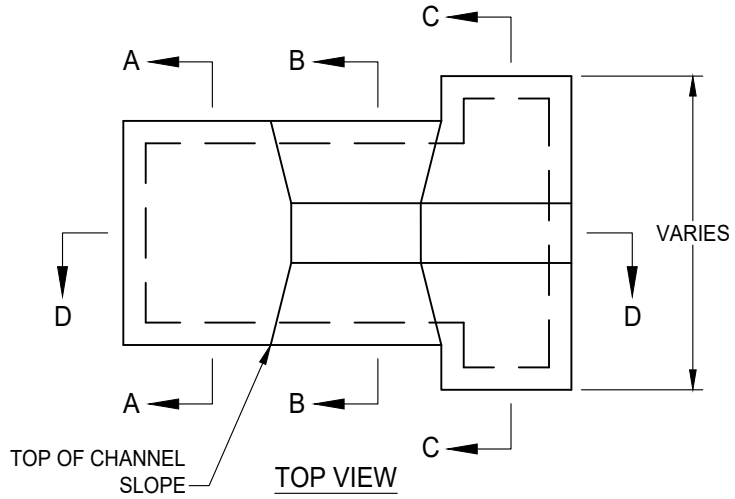

TOP VIEW

NOTES:

1. USE CLASS "B" CONCRETE OR GROUTED COBBLES AS SPECIFIED.
2. 6" x 6" -W6 x W6 WWF THROUGHOUT CONCRETE.
3. ON LINED CHANNELS APRON SHALL CONNECT TO SIDE LINING.
4. B = DITCH BOTTOM WIDTH OR AS SHOWN ON PLANS.
5. D = DITCH WATER DEPTH PLUS ONE FOOT OF FREEBOARD.
6. ADD ENERGY DISSIPATION FEATURES SUCH AS COBBLES, RIP-RAP, OR MOLDED CONCRETE AT END OF APRON.

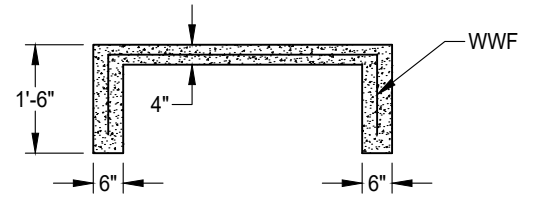

SECTION A-A

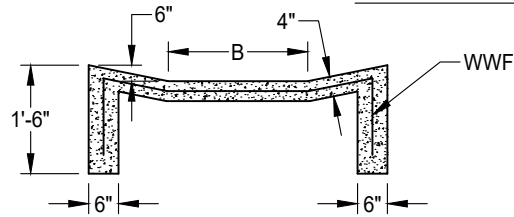

SECTION B-B

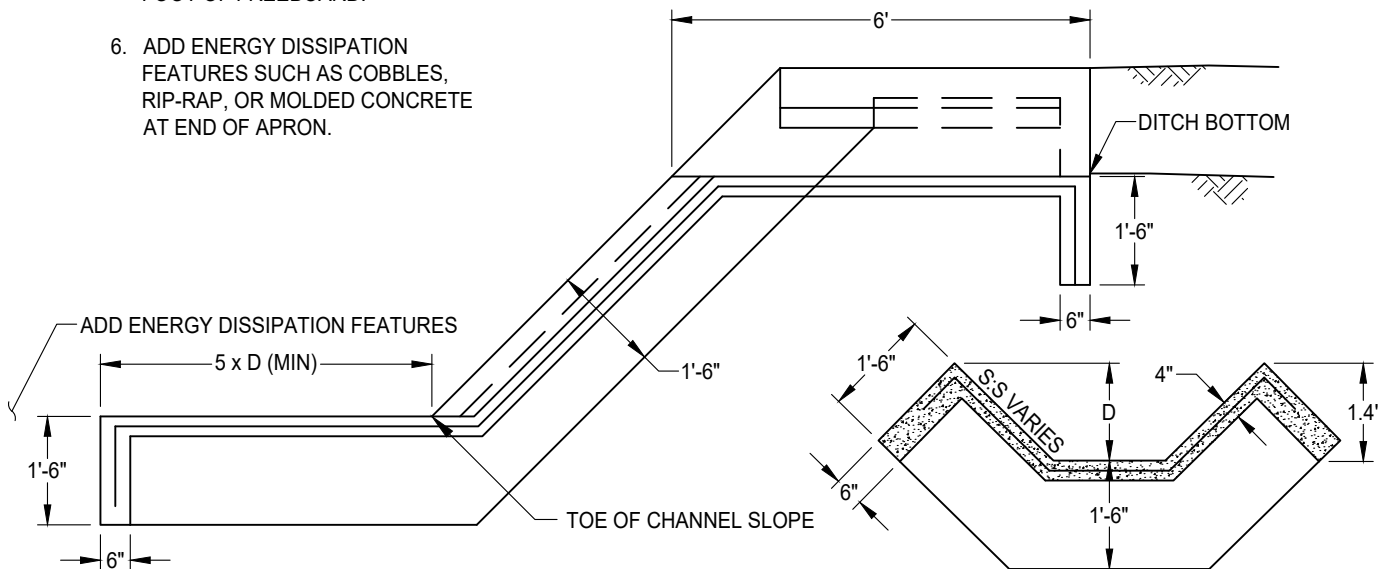

SECTION D-D

SECTION C-C

DATE: 09/22/2017		NOT TO SCALE	
REVISION	BY	APPROVED	DATE
1	SJB	SMA	04-12-2024

CITY OF ELK GROVE - PUBLIC WORKS

DITCH DISCHARGE CONTROL AND APRON

APPROVED BY: _____ 05-28-2024
CITY ENGINEER DATE

DRAWING NUMBER
SD - 27



PIPE DIA. (IN)	PIPE OD (IN)	QUANTITY* BAR "A"	BAR "A" SIZE (IN)	H (IN)	W (IN)	L (IN)	S (IN)
24	30	11	3/8x2 1/2	46	48	40	18
27	33.5	11	3/8x2 1/2	50	48	42	19
30	37	11	3/8x2 1/2	53	48	46	21
33	40.5	11	3/8x2 1/2	57	48	52	24
36	44	13	3/8x2 1/2	60	60	52	24

*INCLUDES OUTSIDE FRAME

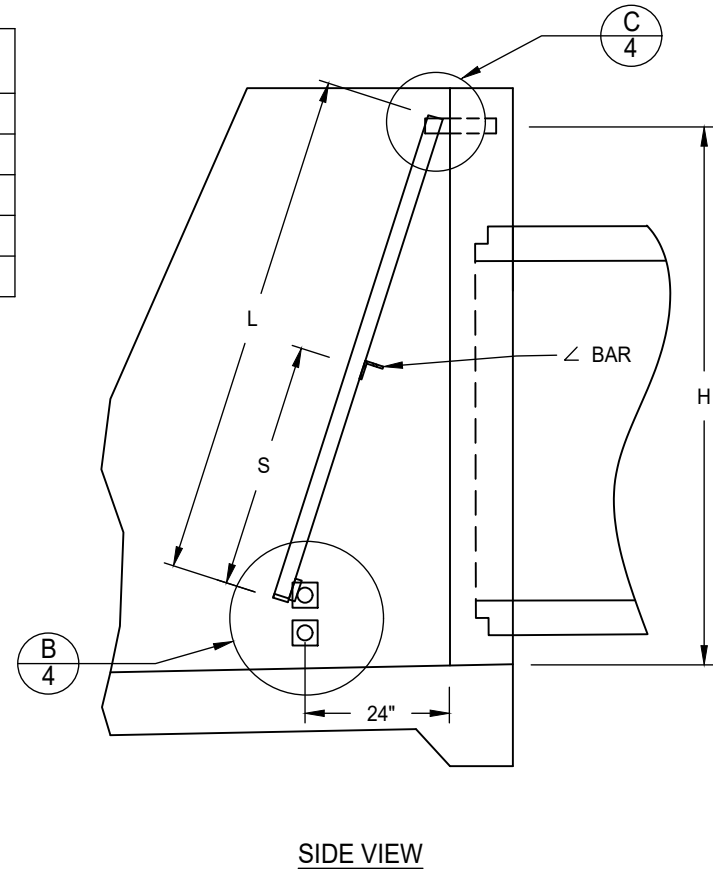
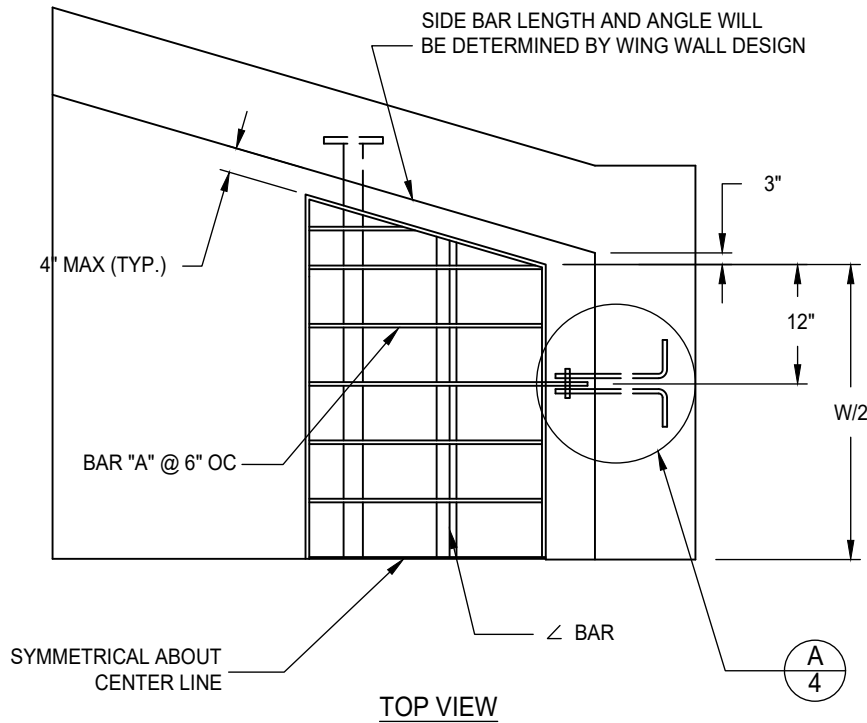

DATE: 09/22/2007		NOT TO SCALE	
REVISION	BY	APPROVED	DATE

CITY OF ELK GROVE - PUBLIC WORKS

TRASH RACK
24"-36" PIPE
(SHEET 1 OF 4)

APPROVED BY:
Paul Murock
 CITY ENGINEER
 DATE: 10/24/2018



DRAWING NUMBER

SD - 28.1

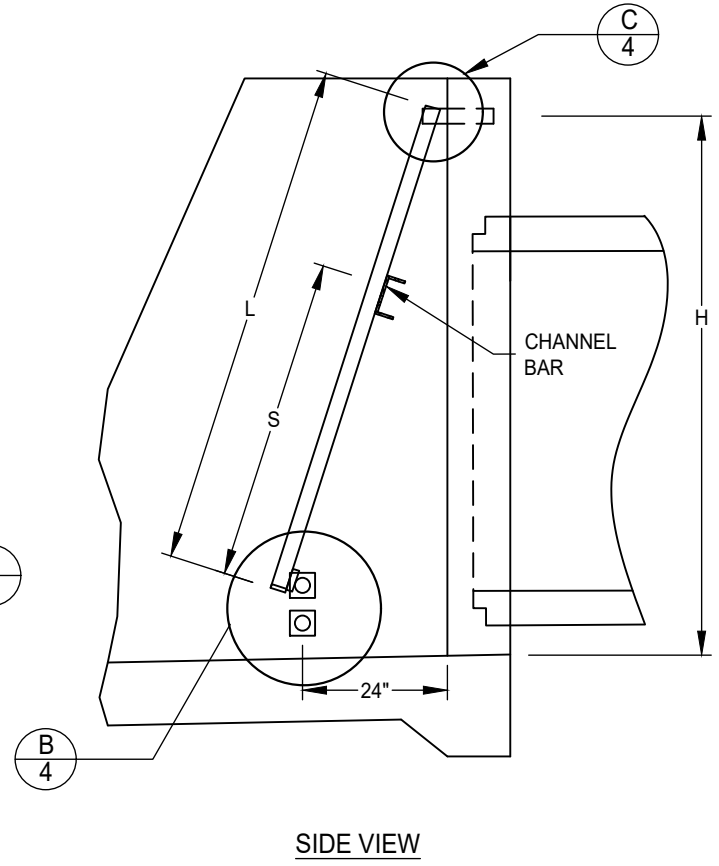
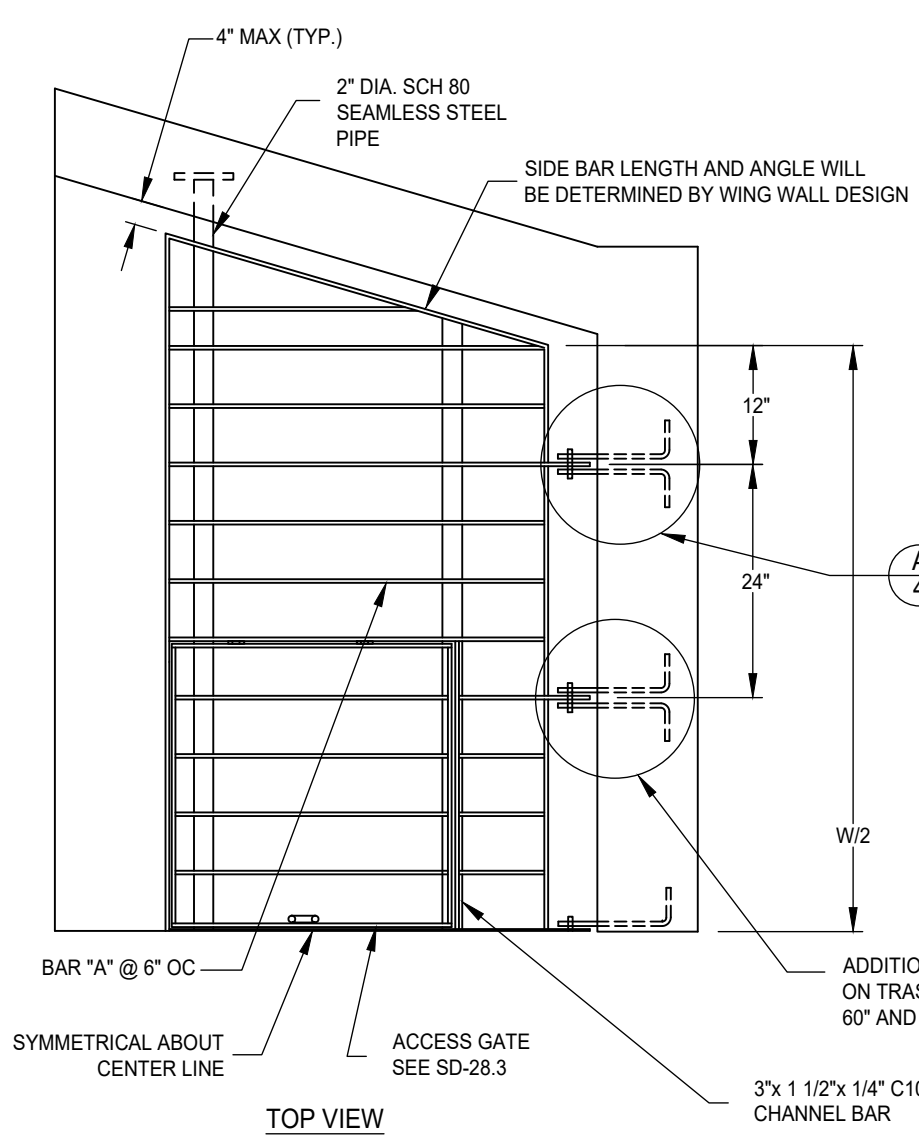

- NOTES:**
1. SEE IMPROVEMENT STANDARDS SECTION 9-17 FOR DESIGN REQUIREMENTS

DATE: 09/22/2007		NOT TO SCALE	
REVISION	BY	APPROVED	DATE

CITY OF ELK GROVE - PUBLIC WORKS

**TRASH RACK
42" PIPE AND LARGER
(SHEET 2 OF 4)**

APPROVED BY:
Paul Murock
CITY ENGINEER

10/24/2018
DATE

DRAWING NUMBER
SD - 28.2



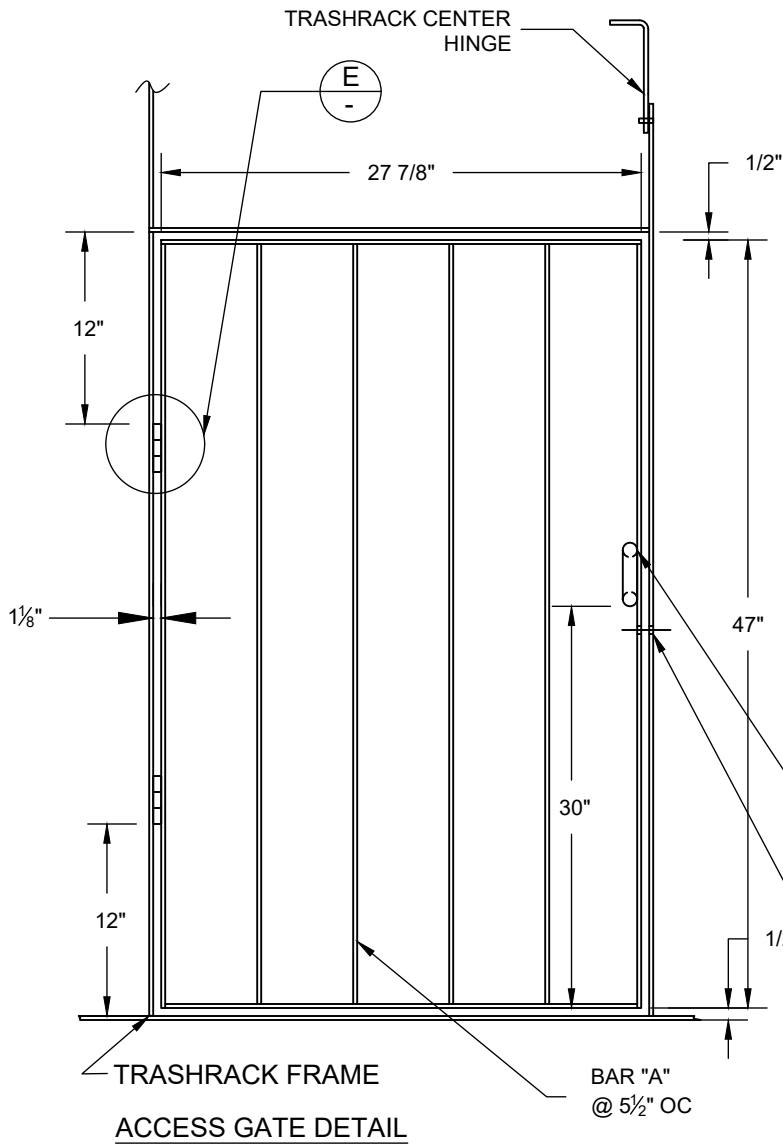

PIPE DIAM (IN)	PIPE OD (IN)	QUANTITY* BAR "A"	BAR "A" SIZE (IN)	H (IN)	W (IN)	L (IN)	S (IN)
42	51	15	3/8x2 1/2	67	72	60	47-3/4
48	58	17	3/8x2 1/2	74	84	70	47-3/4
54	65	21	3/8x2 1/2	81	108	72	47-3/4
60	72	23	3/8x2 1/2	88	120	80	47-3/4
72	86	27	3/8x2 1/2	102	144	96	47-3/4

*INCLUDES OUTSIDE FRAME

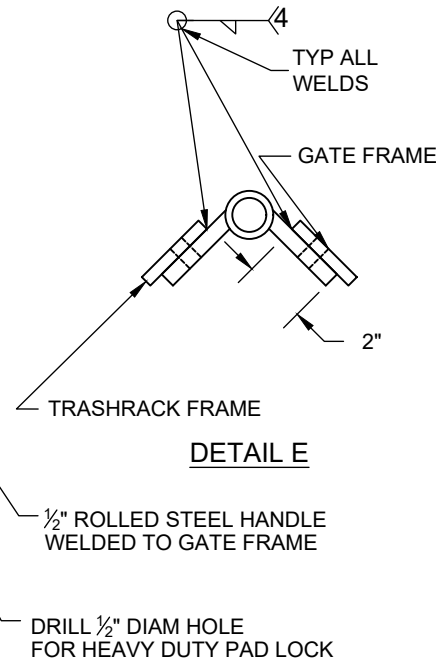

NOTES:

1. SEE STANDARD DRAWINGS SD-29.1 AND SD-29.2 FOR PIPE HEADWALL DETAILS.
2. MATERIAL TO CONFORM TO ASTM DESIGNATION A-36. GALVANIZE ALL EXPOSED FERROUS PARTS AFTER FABRICATION.
3. ALL FILLET WELDS TO BE 3/16".
4. ALL STEEL SHALL CONFORM TO SECTION 75 OF THE STATE SPECIFICATIONS AND ASTM A36, A575 AND A576.
5. GATE HINGES TO BE COATED TO RESIST CORROSION.

DATE: 09/22/2007		NOT TO SCALE	
REVISION	BY	APPROVED	DATE

CITY OF ELK GROVE - PUBLIC WORKS

APPROVED BY:

Paul Murock

10/24/2018

CITY ENGINEER

DATE

**TRASH RACK
42" PIPE AND LARGER
(SHEET 3 OF 4)**



DRAWING NUMBER

SD - 28.3

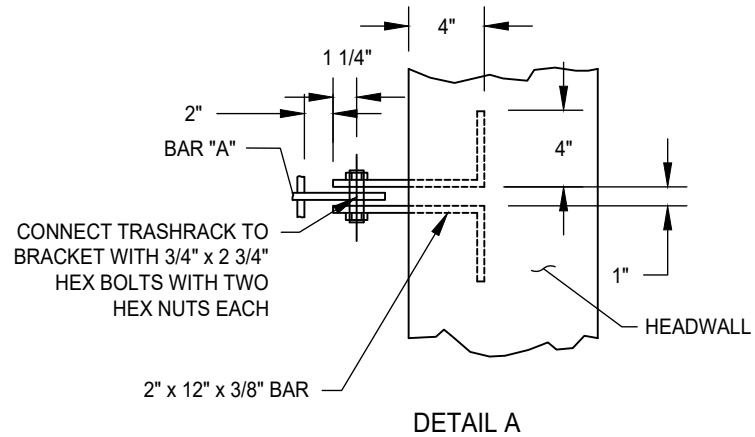

- NOTES:**
1. SEE STANDARD DRAWINGS SD-29.1 AND SD-29.2 FOR PIPE HEADWALL DETAILS.
 2. MATERIAL TO CONFORM TO ASTM DESIGNATION A-36. GALVANIZE ALL EXPOSED FERROUS PARTS AFTER FABRICATION.
 3. ALL FILLET WELDS TO BE 3/16".
 4. ALL STEEL SHALL CONFORM TO SECTION 75 OF THE STATE SPECIFICATIONS AND ASTM A36, A575 AND A576.

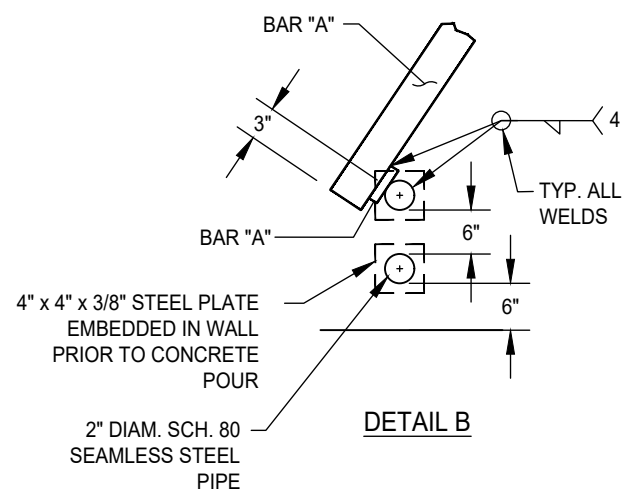
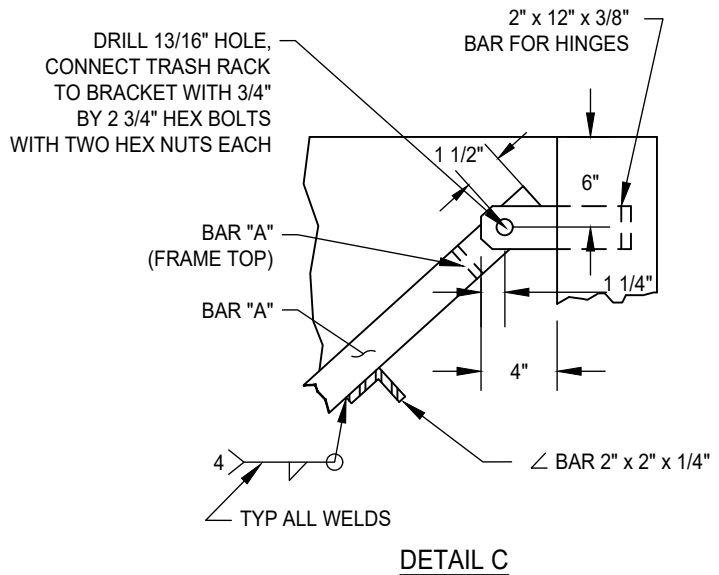

DATE: 09/22/2007		NOT TO SCALE	
REVISION	BY	APPROVED	DATE

CITY OF ELK GROVE - PUBLIC WORKS

**TRASH RACK
DETAILS
(SHEET 4 OF 4)**

APPROVED BY:
Paul Muebeck
CITY ENGINEER

10/24/2018
DATE

DRAWING NUMBER
SD - 28.4



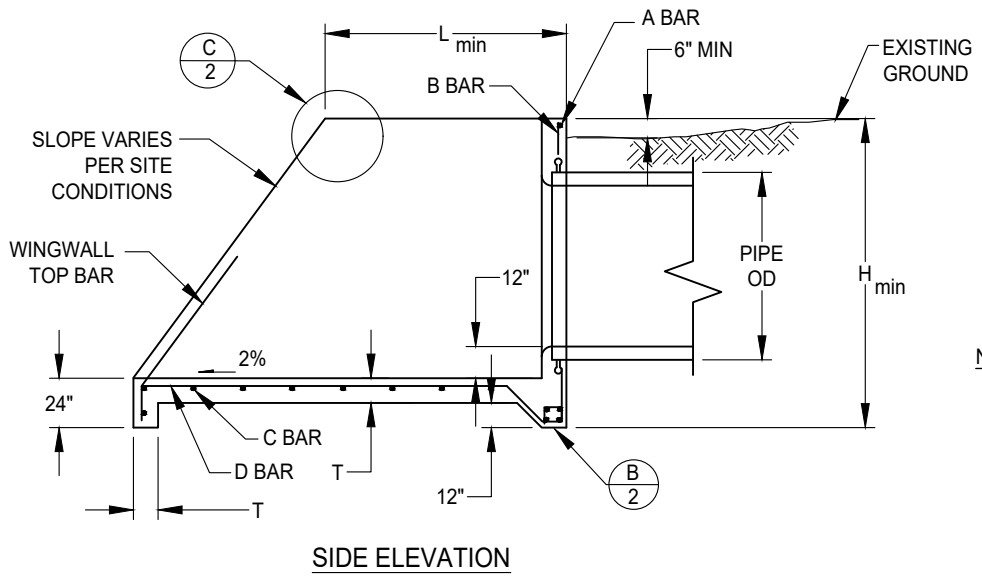
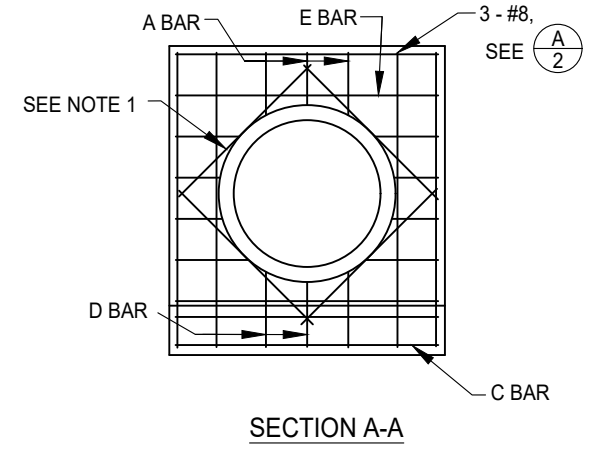
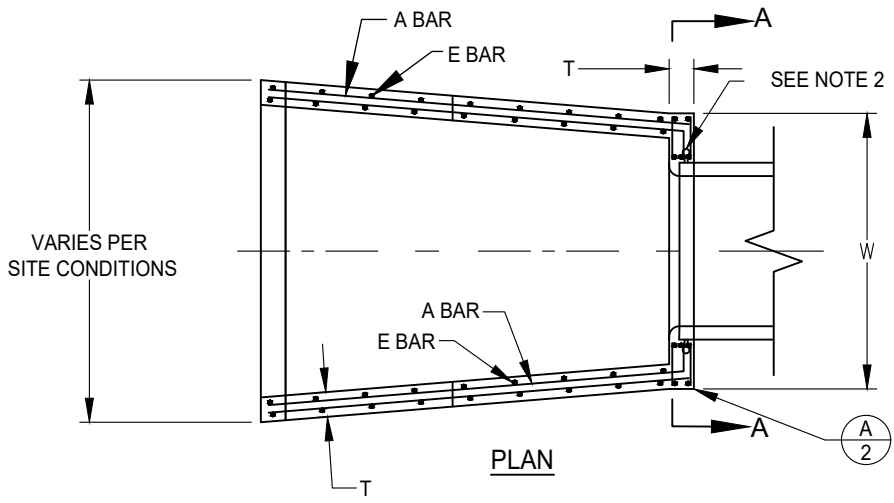

- NOTES:**
- SEE DWG SD-28 FOR EMBEDMENT OF TRASH RACK COMPONENTS PRIOR TO POURING CONCRETE

DATE: 09/22/2007		NOT TO SCALE	
REVISION	BY	APPROVED	DATE

CITY OF ELK GROVE - PUBLIC WORKS

**INLET PIPE HEADWALL
WINGWALL STRUCTURE
(SHEET 1 OF 2)**

APPROVED BY:
Paul Murock
CITY ENGINEER

10/24/2018
DATE

DRAWING NUMBER
SD - 29.1



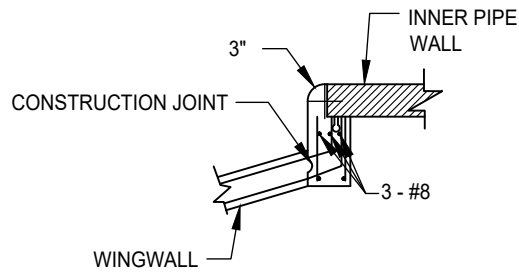

DETAIL A

NOTES:

1. PLACE #5 REBAR ON DIAGONALS @ 4" FROM PIPE OD.
2. PIPE CONNECTIONS SHALL CONFORM TO ASTM C-923. UNITS SHALL INCLUDE A WATER STOP.
3. CHAMFER ALL EXPOSED EDGES 3/4".
4. ALL STEEL MINIMUM 2" FROM CONCRETE EDGES.
5. ALL LAP SPLICES MINIMUM 12".

HEADWALL DIMENSIONS

PIPE DIA	PIPE OD	W	H _{min}	T	L _{min}
24"	30"	4'-6"	4'-8"	8"	2'-9"
27"	33.5"	4'-6"	4'-10"	8"	3'-0"
30"	37"	4'-6"	5'-3"	8"	3'-3"
33"	40.5"	4'-6"	5'-9"	8"	3'-6"
36"	44"	5'-6"	5'-9"	8"	3'-9"
42"	51"	6'-6"	6'-6"	8"	4'-3"
48"	58"	7'-6"	7'-5"	10"	5'-3"
54"	65"	9'-6"	7'-7"	10"	5'-9"
60"	72"	10'-6"	8'-3"	10"	6'-0"
72"	86"	12'-6"	9'-8"	10"	7'-3"

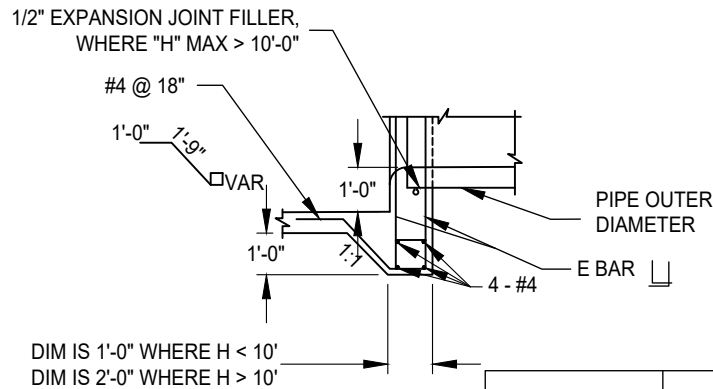

DETAIL B

REINFORCING STEEL DIMENSIONS AND DATA

	A BAR	B BAR	C BAR	D BAR	E BAR	WINGWALL TOP BAR
H ≤ 7'	#4 @ 12"OC	#4 @ 12"OC	#4 @ 12"OC	#4 @ 12"OC	#4 @ 12"OC	#4
7' < H ≤ 8'	#4 @ 12"OC EF	#4 @ 12"OC EF	#4 @ 12"OC EF	#4 @ 12"OC EF	#4 @ 12"OC EF	#4
8' < H ≤ 10'	#5 @ 12"OC EF	#5 @ 6"OC EF	#5 @ 12"OC EF	#5 @ 12"OC EF	#5 @ 12"OC EF	#5

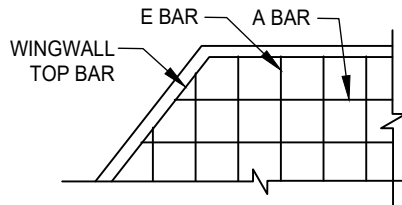

DETAIL C

DATE: 09/22/2007		NOT TO SCALE	
REVISION	BY	APPROVED	DATE

CITY OF ELK GROVE - PUBLIC WORKS

**INLET PIPE HEADWALL
WINGWALL STRUCTURE
(SHEET 2 OF 2)**

APPROVED BY:
Paul Muebeck
CITY ENGINEER

10/24/2018
DATE

DRAWING NUMBER
SD - 29.2



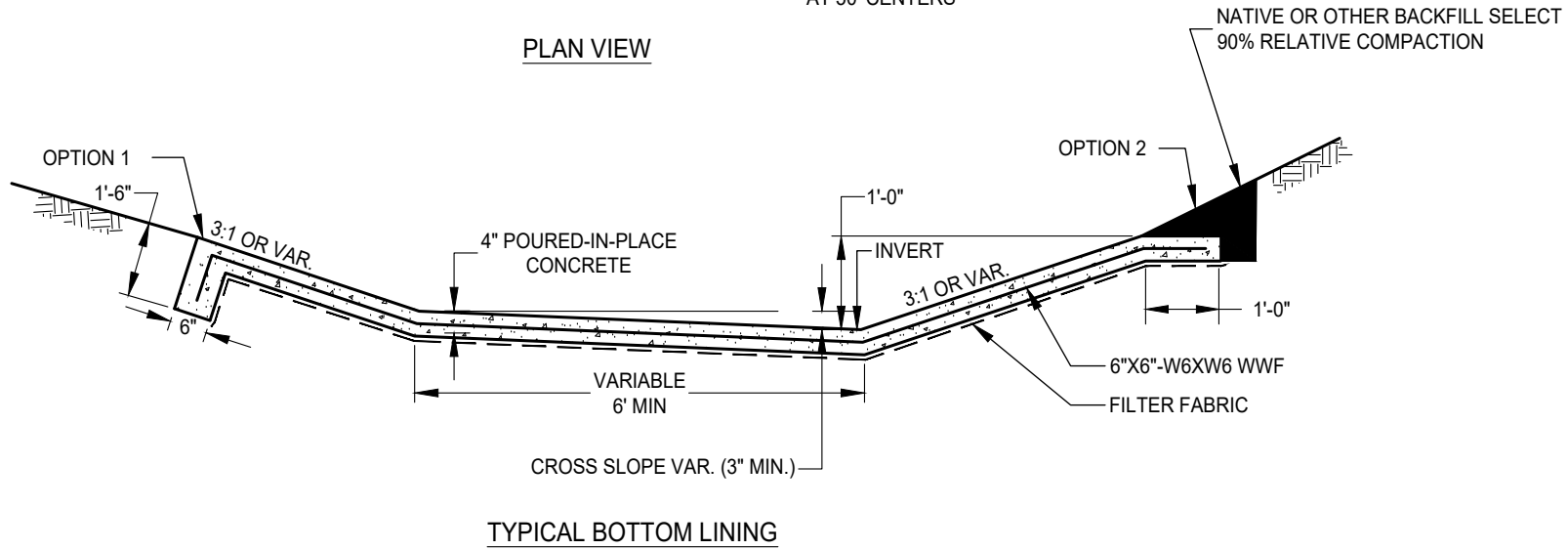
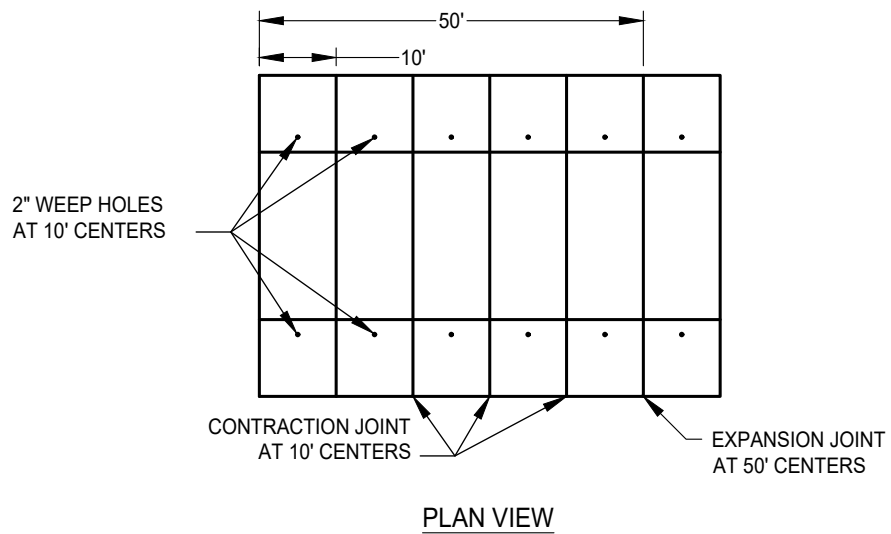

DATE: 09/22/2007		NOT TO SCALE	
REVISION	BY	APPROVED	DATE

CITY OF ELK GROVE - PUBLIC WORKS

**LINED CHANNEL SECTION
(SHEET 1 OF 2)**

APPROVED BY:
Paul Murock
CITY ENGINEER

10/24/2018
DATE

DRAWING NUMBER
SD - 30.1



OPTION 2

NATIVE OR OTHER SELECT BACKFILL 90%
RELATIVE COMPACTION

WEEP HOLE SHALL BE CENTERED IN A MINIMUM OF 1
C.F. OF 3/4" CRUSHED ROCK CONFORMING TO
SECTION 50 "CLEAN CRUSHED ROCK", TYPE B. ROCK
SHALL BE WRAPPED IN FABRIC CONFORMING TO
SECTION 50 "GEOTEXTILE FABRIC". HOLE SHALL BE 2"
DIAMETER PIPE CUT TO FIT FLUSH WITH CHANNEL
FACE. (TYPICAL)

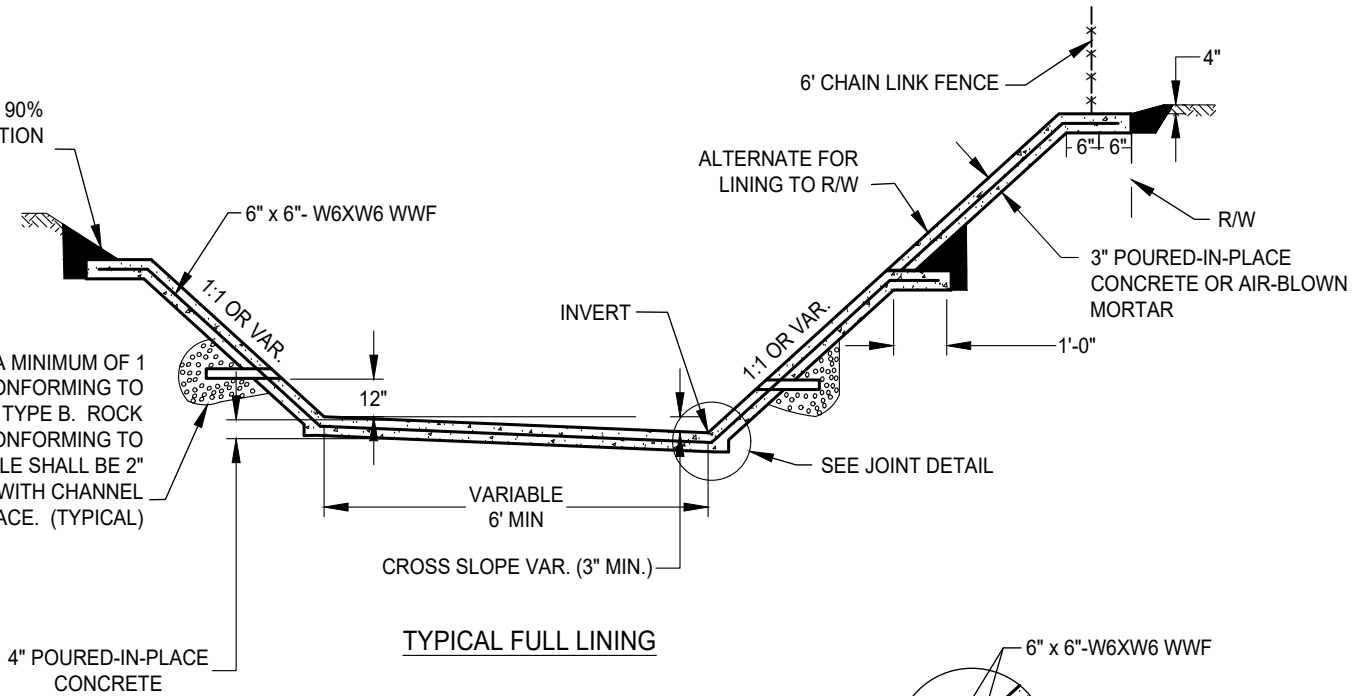

TYPICAL FULL LINING

OPTION 1

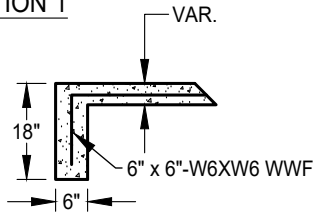

CUTOFF WALL

TO BE PLACED ALONG ENTIRE END OF LINED
SECTION AT BEGINNING AND AT END OF
LINING

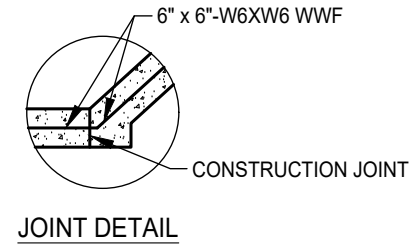

JOINT DETAIL

DATE: 09/22/2007		NOT TO SCALE	
REVISION	BY	APPROVED	DATE

CITY OF ELK GROVE - PUBLIC WORKS

**LINED CHANNEL SECTION
(SHEET 2 OF 2)**

APPROVED BY:

Paul Murock

CITY ENGINEER

10/24/2018

DATE

DRAWING NUMBER

SD - 30.2



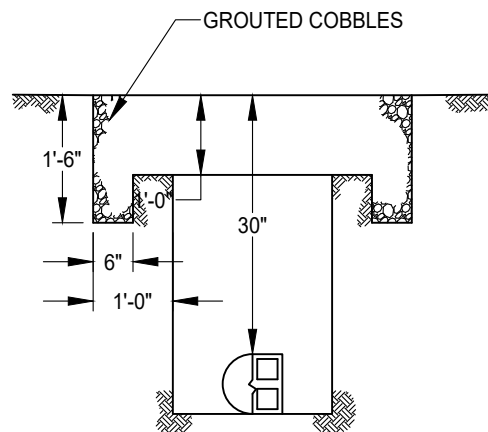
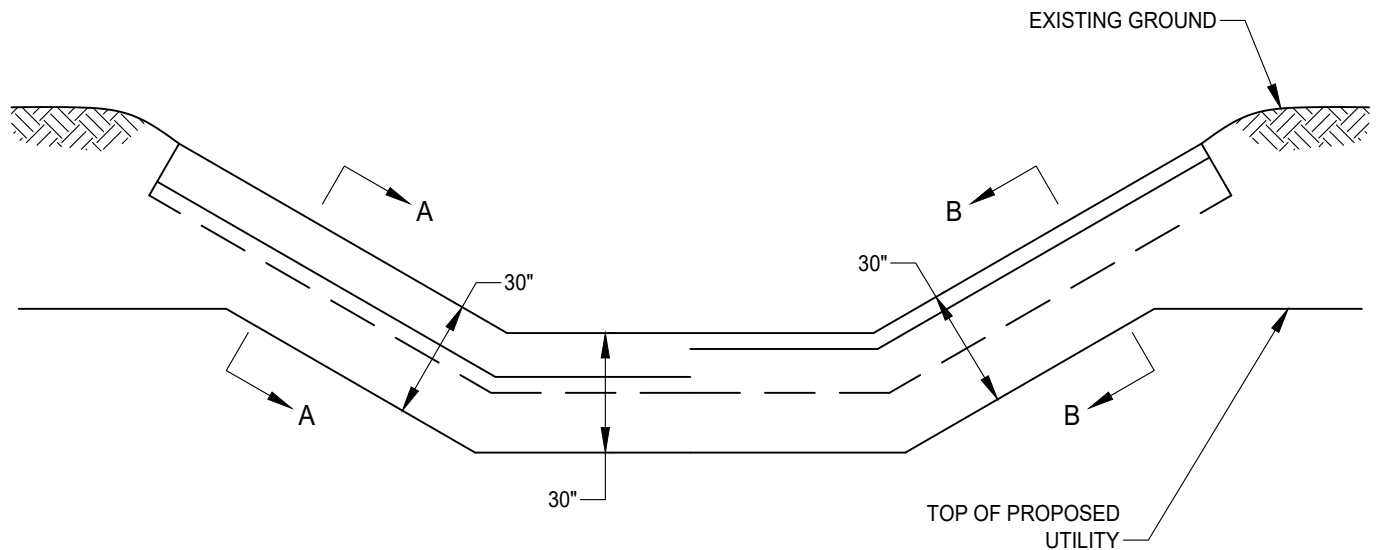

SECTION A-A

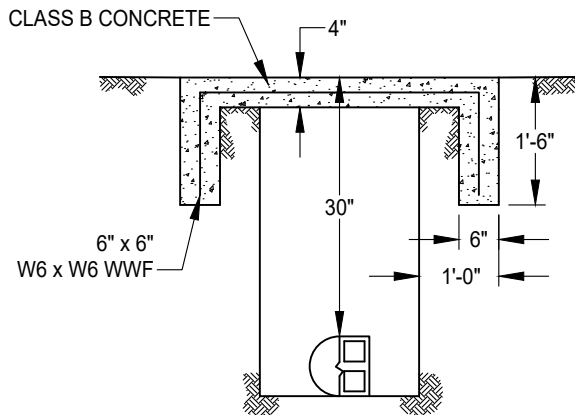

SECTION B-B

NOTES:

1. ALL UTILITY CROSSINGS OF EXISTING STREAMS SHALL BE AT LEAST 30" BELOW EXISTING CHANNEL SIDES AND BOTTOMS. DEEPER PLACEMENT MAY BE REQUIRED IF FUTURE CHANNEL IMPROVEMENTS ARE ANTICIPATED.
2. THE CUT SHALL BE SEALED AS SHOWN WITH GROUTED COBBLES OR CLASS B CONCRETE TO A WIDTH OF 1 FOOT EACH SIDE OF THE UTILITY TRENCH. ALL NATURAL STREAMS, AS SHOWN ON THE NATURAL STREAMS PLAN, SHALL UTILIZED GROUTED COBBLES.
3. CONSTRUCTION IS TO CONFORM TO SECTION 44-2.07 OF THE CITY OF ELK GROVE STANDARD CONSTRUCTION SPECIFICATIONS WITH CUT OFF WALLS CONFORMING TO STANDARD DRAWING SD-30.2 (OPTION 1).

DATE: 09/22/2017		NOT TO SCALE	
REVISION	BY	APPROVED	DATE
1	SJB	SMA	04-12-2024

CITY OF ELK GROVE - PUBLIC WORKS

UTILITY STREAM CROSSING

APPROVED BY:

 05-28-2024
 CITY ENGINEER DATE

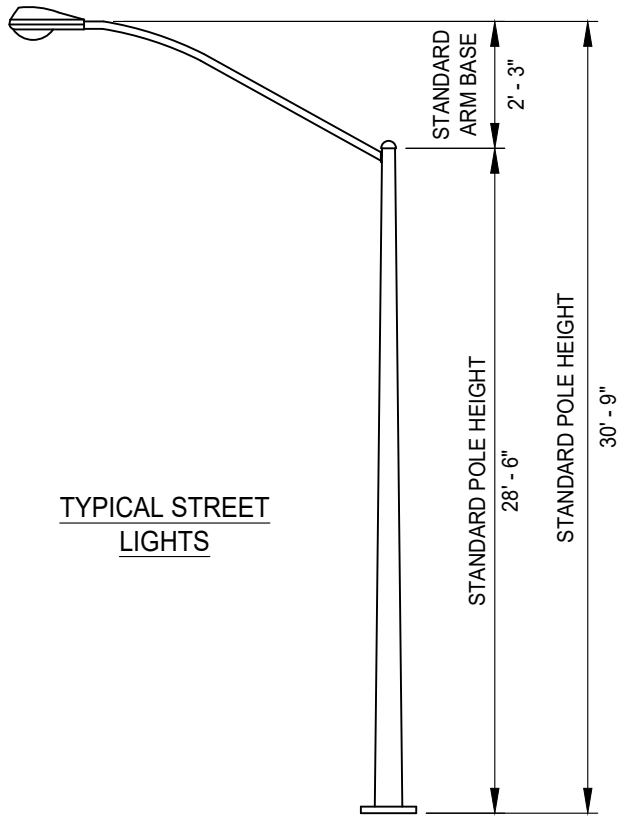

DRAWING NUMBER

SD - 31



TYPICAL STREET LIGHTS

SERIES 'A'

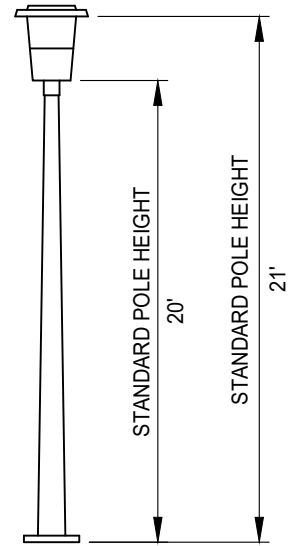

SERIES 'B'

SYMBOLS

PROPOSED	EXISTING	
	SERIES 'A' STREET LIGHT
	SERIES 'B' STREET LIGHT
	PULL BOX
	SERVICE POINT PULL BOX
	CONDUIT
	SERVICE ENCLOSURE
	U.G. UTILITY SERVICE
	TRANSFORMER
	WOOD POLE

DATE: 09/22/2017		NOT TO SCALE	
REVISION	BY	APPROVED	DATE

CITY OF ELK GROVE - PUBLIC WORKS

**STREET LIGHTING
POLES AND SYMBOLS**

APPROVED BY:
Paul Murbach
CITY ENGINEER

10/24/2018
DATE

DRAWING NUMBER
SL - 1



STREET CLASSIFICATION	RIGHT-OF-WAY WIDTH	STREET LIGHT SUB-TYPE (SERIES)	STANDARD MOUNTING TYPE	AVERAGE MAINTAINED FOOTCANDLE	MAINTENANCE FACTOR
SPECIAL THOROUGHFARE	118'	A	30' - 9"	0.57	0.65
THOROUGHFARE	96'	A	30' - 9"	0.56	0.65
ARTERIAL	72'	A	30' - 9"	0.36	0.65
COLLECTOR	60'	A	30' - 9"	0.26	0.65
RESIDENTIAL	< 50'	B	21'	0.13	0.70
PEDESTRIAN LANE	--	B	14'	0.17	0.70

NOTES:

1. LUMENS USED TO CALCULATE THE AVERAGE MAINTAINED FOOTCANDLE SHALL BE 80% OF INITIAL LUMEN VALUE RATED BY THE LAMP MANUFACTURER.

DATE: 09/22/2007		NOT TO SCALE		CITY OF ELK GROVE - PUBLIC WORKS		APPROVED BY: <i>Paul Murock</i>	
REVISION	BY	APPROVED	DATE	STREET LIGHTING ILLUMINATION CRITERIA		CITY ENGINEER	10/24/2018 DATE
							DRAWING NUMBER
							SL - 2

ELECTROLIER MUST BE GROUNDED BACK TO THE SERVICE POINT

GALVANIZED ANCHOR BOLTS **

BASE PLATE **

SIDEWALK FINISH (IF APPLICABLE)

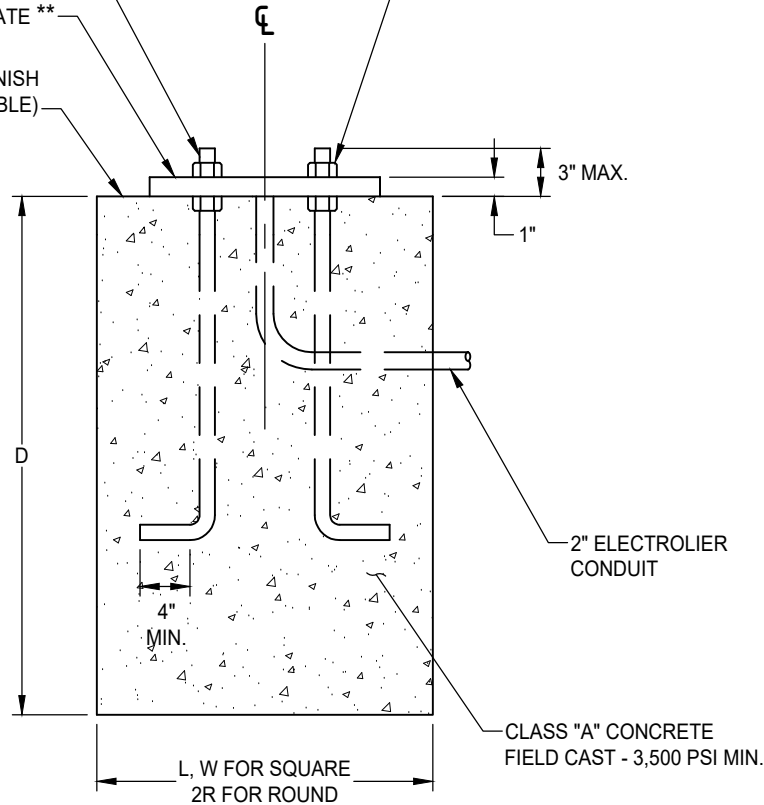

ELEVATION

MINIMUM FOUNDATION DIMENSIONS *						
STREET LIGHT AREAS	STREET LIGHT SUB-TYPE (SERIES)	SQUARE			ROUND	
		L	W	D	R	D
CT	SERIES 'A'	30"	30"	5'	15"	5'
CT, OT, LW	SERIES 'B'	24"	24"	4'	12"	4'
LW, ZONE 2	SERIES 'A'	30"	30"	6'-6"	15"	6'-6"
ZONE 2	SERIES 'B'	24"	24"	4'-6"	12"	4'-6"

CT - COMMON TYPE
 OT - OLD TOWN
 LW - LAGUNA WEST

SEE STANDARD DRAWING SL-19 FOR STREET LIGHT AREAS

- * STABLE SOILS ONLY. UNSTABLE SOIL MAY REQUIRE A DEEPER FOUNDATION AS DETERMINED BY THE DESIGN ENGINEER.
- * IN LIEU OF USING THE STANDARD MINIMUM DIMENSIONS, A LICENSED PROFESSIONAL ENGINEER MAY SUBMIT A SITE-SPECIFIC (BY STREET LIGHT TYPE/LOCATION) FOUNDATION DESIGN FOR APPROVAL. FOUNDATION DESIGN MUST CONFORM TO AASHTO "STANDARD SPECIFICATIONS FOR STRUCTURAL SUPPORTS FOR HIGHWAY SIGNS, LUMINAIRES, AND TRAFFIC SIGNALS."
- ** ANCHOR BOLT SIZES AND BASE PLATE SHALL BE PURSUANT TO THE POLE MANUFACTURER'S DESIGN REQUIREMENTS, WHICH SHALL BE IN ACCORDANCE WITH AASHTO "STANDARD SPECIFICATIONS FOR STRUCTURAL SUPPORTS FOR HIGHWAY SIGNS, LUMINAIRES, AND TRAFFIC SIGNALS."

DATE 09/22/2007		NOT TO SCALE	
REVISION	BY	APPROVED	DATE
01	STN	JRW	02/16/2021

CITY OF ELK GROVE - PUBLIC WORKS

APPROVED BY:

Robert M. Mudgett

02/26/2021

CITY ENGINEER

DATE

STREET LIGHT FOUNDATIONS



DRAWING NUMBER

SL - 3

PULL BOX No.	REINFORCED CONCRETE BOX				COMPOSITE BOX		REINFORCED CONC. OR COMPOSITE COVER				
	MIN.** THICKNESS	MIN DEPTH BOX AND EXTENSION	LO	WO	MIN.** THICKNESS	MIN DEPTH BOX AND EXTENSION	L***	W***	R	EDGE THICKNESS	EDGE TAPER
3-1/2	1"	NO EXTENSION	20"	14"	5/16"	NO EXTENSION	15-3/8"	10-1/8"	1-1/8"	1-3/4"	1/8"
5	1"	22"	28"	18"	5/16"	20"	23-1/4"	13-3/4"	1-1/4"	2"	1/8"
5A	1"	22"	25-1/4"	15-3/4"	5/16"	20"	20-5/8"	10-1/2"	1-1/4"	2"	1/8"
6	1-1/2"	24"	36"	23"	3/8"	20"	30-5/8"	17-5/8"	1-1/4"	2"	1/8"
P44	1-1/2"	20"	47-1/2"	28-1/4"	-	-	43-1/8"	21-1/4"	1-1/2"	2"	1/8"

NOTES:

- IN UNIMPROVED AREAS, THE TOP OF PULL BOXES SHALL BE PLACED 0.10 FOOT ABOVE THE SURROUNDING GRADE OR, WHEN ADJACENT TO A CURB, FLUSH WITH THE TOP OF THE CURB. THE SURROUNDING GRADE SHALL BE RAMPED UP TO MATCH THE TOP OF THE CONCRETE COLLAR. UNLESS OTHERWISE NOTED, PULL BOXES SHOWN IN THE VICINITY OF SIDEWALK SHALL BE PLACED ADJACENT TO THE BACK OF SIDEWALK, AND PULL BOXES SHOWN ADJACENT TO POLES SHALL BE PLACED ON THE SIDE OF THE FOUNDATION FACING AWAY FROM TRAFFIC.
- PLACEMENT OF PULL BOXES IN AREAS SUBJECT TO VEHICULAR TRAFFIC LOADS (INCLUDES TRAFFIC LANES, BIKE LANES, SHOULDERS, AND DRIVEWAYS) SHALL BE AVOIDED WHENEVER POSSIBLE. IF UNAVOIDABLE, THEN A TRAFFIC RATED PULL BOX WITH STEEL TRAFFIC COVER SHALL BE USED. SEE STANDARD DRAWING SL-5.
- PULL BOXES SHALL NOT BE PLACED WITHIN THE BOUNDARIES AND SIDEWALK RAMPS.
- FINAL LOCATION OF ALL PULL BOXES SHALL BE APPROVED BY CITY INSPECTOR PRIOR TO PLACEMENT.
- PULL BOX COVERS SHALL BE MARKED AS FOLLOWS:
 - "TRAFFIC SIGNAL" TRAFFIC SIGNAL CIRCUITS WITH OR WITHOUT STREET LIGHTING CIRCUITS.
 - "STREET LIGHTING" STREET LIGHTING CIRCUITS WHERE NO VOLTAGE IS ABOVE 600V.
 - "STREET LIGHTING-HIGH VOLTAGE" STREET LIGHTING CIRCUITS WHERE VOLTAGE IS ABOVE 600V.
 - "SERVICE" SERVICE CIRCUITS BETWEEN SERVICE POINT AND SERVICE DISCONNECT.
 - "SPRINKLER CONTROL" SPRINKLER CONTROL CIRCUITS, 50 VOLTS OR LESS.
 - "IRRIGATION" CIRCUIT FOR IRRIGATION CONTROLLER, 120 VOLTS OR MORE.
 - "RAMP METER" RAMP METER CIRCUITS.
 - "COUNT STATION" COUNT AND/OR SPEED MONITOR CIRCUITS.
 - "TELEPHONE" TELEPHONE SERVICE.
 - "TOS COMMUNICATIONS" TOS COMMUNICATIONS TRUNK LINE.
 - "TOS POWER" TOS POWER.
 - "TDC POWER" TELEPHONE DEMARCATION CABINET POWER.
 - "SIGNAL INTERCONNECT" TRAFFIC SIGNAL INTERCONNECT CIRCUIT.
- COVERS SHALL FIT FLUSH WITH THE TOP OF PULL BOXES. THERE SHALL BE 1/8" MAXIMUM CLEARANCE ALL AROUND BETWEEN COVERS AND PULL BOX OPENINGS.
- ALL COVERS AND BOXES SHALL BE INTERCHANGEABLE WITH CALIFORNIA STANDARD MALE AND FEMALE GAUGES. WHEN INTERCHANGED WITH STANDARD MALE OR FEMALE GAUGE, THE TOP SURFACES SHALL BE FLUSH WITHIN 1/8 INCH.
- THE TOP EDGES OF ALL CONCRETE COVER AND PULL BOXES SHALL HAVE A 1/4" MINIMUM RADIUS.
- STACKING OF PULL BOXES IS PERMITTED (TWO PULL BOXES MINIMUM).
- STEEL REINFORCING SHALL BE A REGULARLY USED IN THE STANDARD PRODUCTS OF THE RESPECTIVE MANUFACTURER.
- PULL BOXES FOR STREET LIGHTING, UPON COMPLETION OF BURN TEST, SHALL BE FILLED WITH CONTROLLED DENSITY BACKFILL, PER CITY OF ELK GROVE CONSTRUCTION SPECIFICATIONS SECTION 50-15. A 5 MIL. PLASTIC SHEET SHALL COVER THE CONDUITS/WIRES PRIOR TO POURING OF BACKFILL TO A DEPTH OF TWO (2) INCHES OVER THE CONDUITS.
- WHEN NON-METALLIC CONDUIT IS USED AND CONDUIT SWEEPS ARE METALLIC, THE BONDING JUMPER SHALL BE CONNECTED TO THE SWEEP GROUND BUSHINGS AND SHALL BE SPLICED TO THE GROUND WIRE IN THE CONDUIT.

** EXCLUDING CONDUIT WEB *** TOP DIMENSION

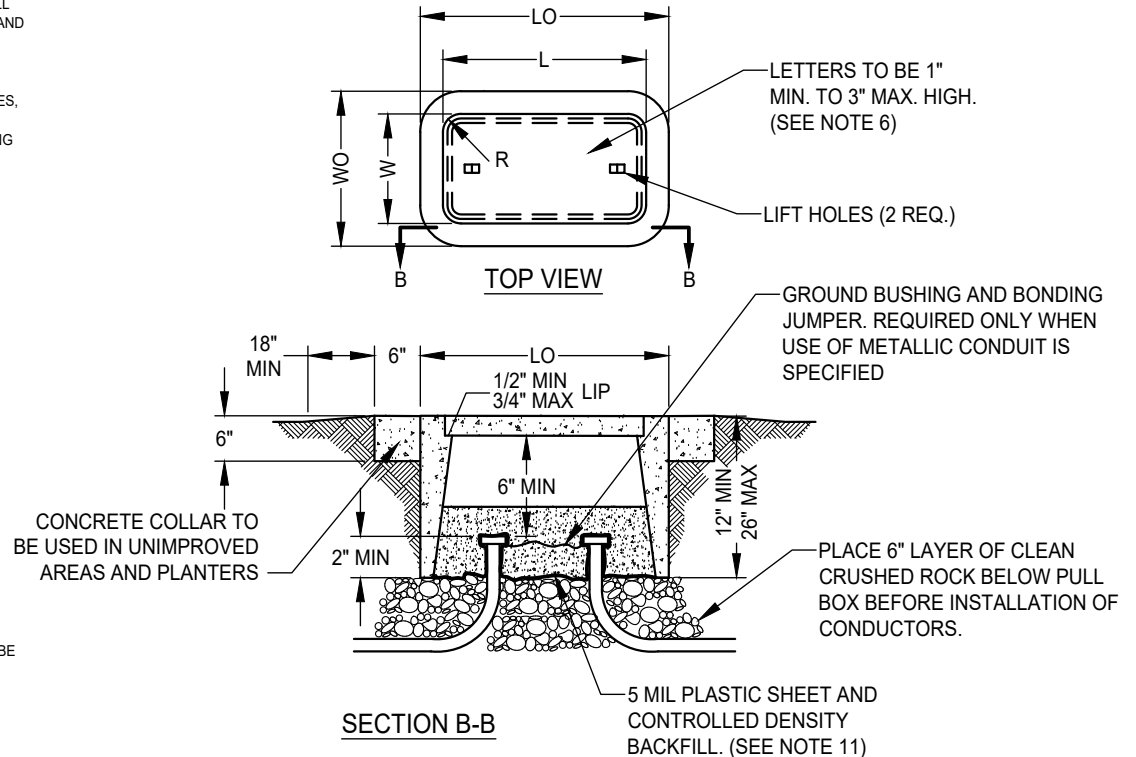

DATE: 09/22/2007		NOT TO SCALE	
REVISION	BY	APPROVED	DATE
1	SJB	SMA	04-12-2024

CITY OF ELK GROVE - PUBLIC WORKS

STANDARD PULL BOX

APPROVED BY: _____

05-28-2024

CITY ENGINEER _____ DATE

DRAWING NUMBER

SL - 4

PULL BOXES SHALL BE PLACED BEHIND THE SIDEWALK OR IN THE PLANTER AREA WHENEVER POSSIBLE. TRAFFIC RATED BOXES AND COVERS SHALL BE USED IF A PULL BOX MUST BE INSTALLED IN THE SIDEWALK OR DRIVEWAY.

NOTES:

1. STEEL COVER SHALL HAVE EMBOSSED NON-SKID PATTERN.
2. STEEL REINFORCING SHALL BE AS REGULARLY USED IN THE STANDARD PRODUCTS OF THE RESPECTIVE MANUFACTURER.
3. PULL BOX COVERS SHALL BE MARKED AS DESCRIBED IN NOTE 5 ON STANDARD DRAWING SL-4. MARKING SHALL BE APPLIED TO EACH COVER PRIOR TO GALVANIZING BY BEAD WELDING THE LETTERS ON THE COVERS. THE LETTERS SHALL BE RAISED AT LEAST 3/32 INCH.
4. BONDING JUMPER FOR COVER SHALL BE A MIN. OF 36" LONG. WHEN NON-METALLIC CONDUIT IS USED, THE BONDING JUMPER SHALL INCORPORATE CONNECTION TO THE METALLIC CONDUIT SWEEPS AND BE SPLICED TO THE GROUND WIRE IN THE CONDUITS. WHEN THE USE OF METALLIC CONDUIT IS SPECIFIED, THE BONDING JUMPER FOR THE COVER SHALL BE CONNECTED TO THE CONDUIT GROUND BUSHING, AND THE CONDUITS SHALL BE BONDED TOGETHER WITH GROUND BUSHINGS AND A BONDING JUMPER.
5. CONDUITS SHALL ENTER AT BOTTOM OF PULL BOX AS SHOWN IN THE DRAWING.
6. PULL BOXES FOR STREET LIGHTING, UPON COMPLETION OF BURN TEST, SHALL BE FILLED WITH CONTROLLED DENSITY BACKFILL PER CITY OF ELK GROVE CONSTRUCTION SPECIFICATIONS SECTION 50-15. A 5 MIL. PLASTIC SHEET SHALL COVER THE CONDUITS/WIRES PRIOR TO POURING OF BACKFILL, TO A DEPTH OF TWO (2) INCHES OVER THE CONDUITS.

REINFORCED CONCRETE BOX						
PULL BOX No.	MIN.** THICKNESS	MIN. DEPTH BOX AND EXTENSION	LO	WO	L	W
3-1/2	1"	NO EXTENSION	20"	14"	15-1/2"±	10"±
5	1"	22"	28"	18"	23"±	13-1/2"±
5A	1"	22"	25-1/4"	15-3/4"	21"±	10-1/2"±

** EXCLUDING CONDUIT WEB

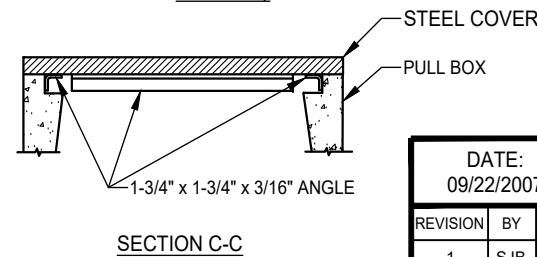
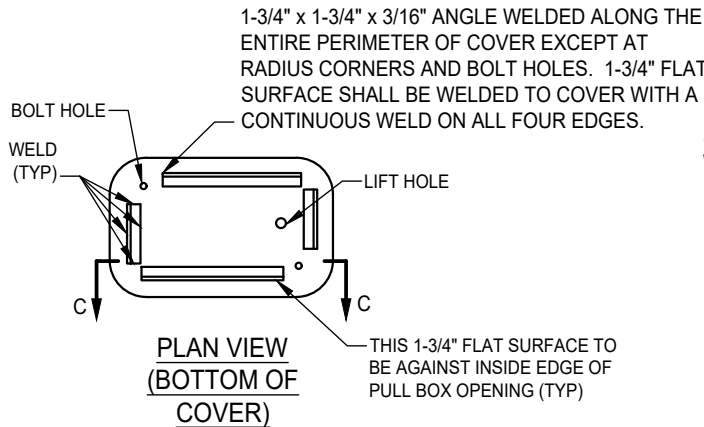
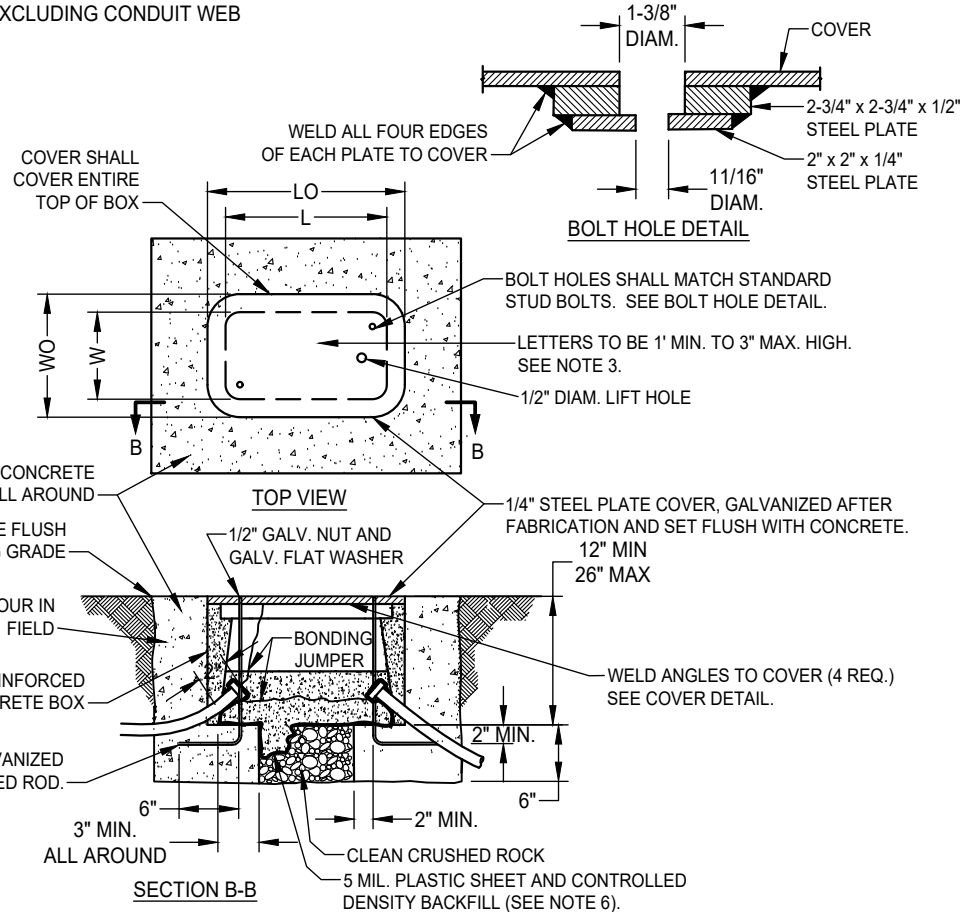

DATE: 09/22/2007		NOT TO SCALE	
REVISION	BY	APPROVED	DATE
1	SJB	SMA	04-12-2024

CITY OF ELK GROVE - PUBLIC WORKS

TRAFFIC-RATED PULL BOX

APPROVED BY:

[Signature] 05-28-2024

CITY ENGINEER

DATE



DRAWING NUMBER

SL - 5

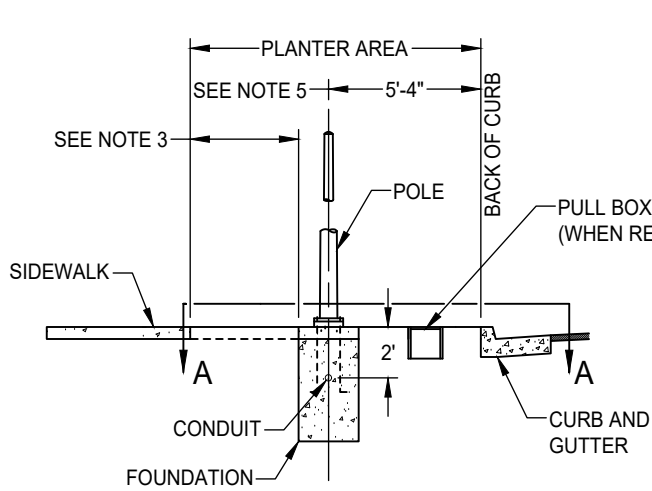

SIDEWALK WITH PLANTER AREA

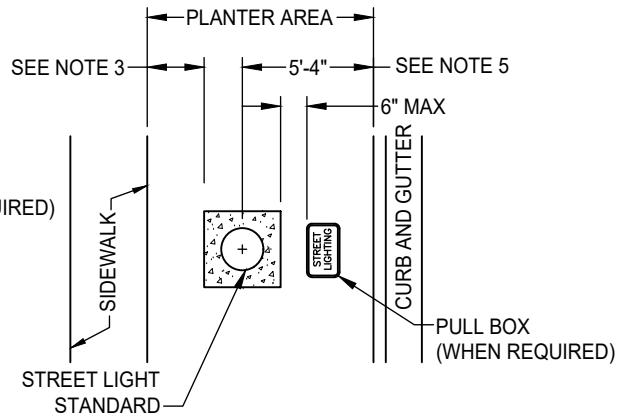

SECTION A-A

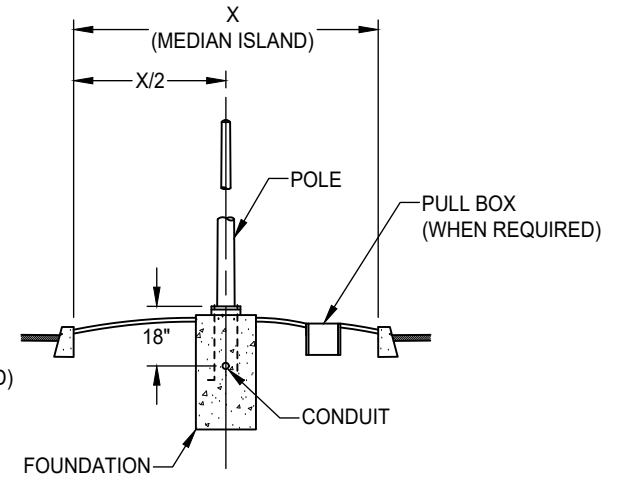

MEDIAN

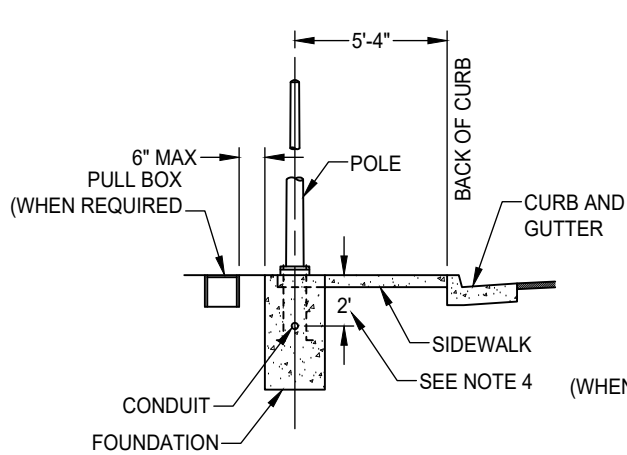

5' TO 6' SIDEWALK

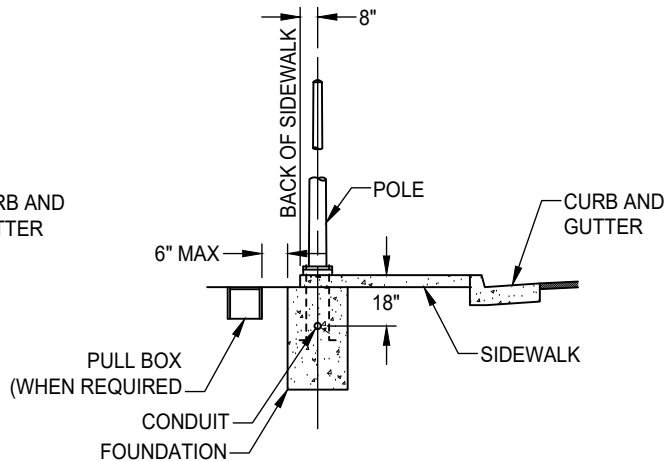

OVER 6' SIDEWALK

NOTES:

1. BACKFILL FOR CONDUIT TRENCH LOCATED UNDER CURB, GUTTER & SIDEWALK AND IN UNIMPROVED AREAS SHALL BE COMPACTED TO 90% RELATIVE COMPACTION. BACKFILL FOR CONDUIT TRENCH LOCATED IN PAVEMENT SHALL BE COMPACTED TO 95% RELATIVE COMPACTION.
2. LANDSCAPING IN THE AREA OF THE STREET LIGHT STANDARD TO MATCH BASE ELEVATION AND HAVE A MINIMUM OF 12" OF CLEARANCE FROM THE BASE.
3. IF THIS LENGTH IS 12" OR LESS, PLACE 3-1/2" THICK CONCRETE FROM STREET LIGHT BASE TO EDGE OF SIDEWALK. WIDTH TO MATCH CONCRETE AROUND STREET LIGHT FOUNDATION.
4. IF CONDUIT IS LOCATED BENEATH THE SIDEWALK, IT MAY BE PLACED AT 18" DEPTH INSTEAD OF 2'.
5. IF THE PLANTER AREA IS LESS THAN 6' WIDE, THEN PLACE STREET LIGHT SO THAT THE BASE PLATE ALIGNS WITH THE EDGE OF SIDEWALK. TOP OF FOUNDATION TO MATCH SIDEWALK GRADE.
6. PULL BOXES SHALL NOT BE PLACED IN SIDEWALK. THEY SHALL BE PLACED IN PUE OR PLANTER AREA.

DATE: 09/22/2007		NOT TO SCALE	
REVISION	BY	APPROVED	DATE

CITY OF ELK GROVE - PUBLIC WORKS

BASE LOCATION FOR STREET LIGHT

APPROVED BY:

Paul Murock

CITY ENGINEER

10/24/2018

DATE



DRAWING NUMBER

SL - 6

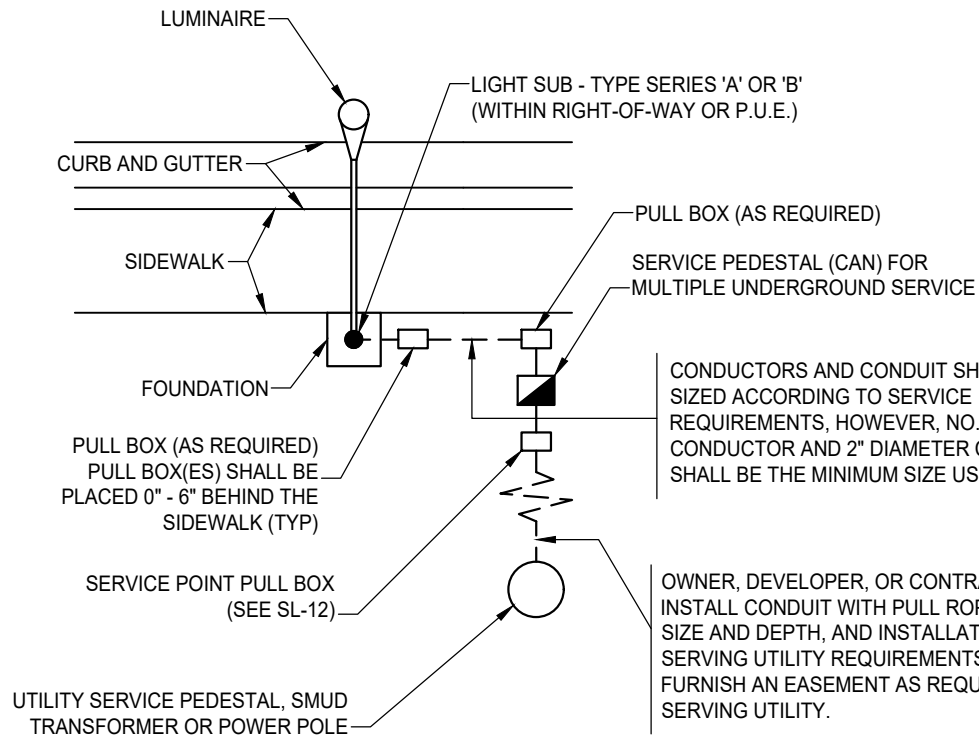

CONDUCTORS AND CONDUIT SHALL BE SIZED ACCORDING TO SERVICE REQUIREMENTS, HOWEVER, NO. 8 A.W.G. CONDUCTOR AND 2" DIAMETER CONDUIT SHALL BE THE MINIMUM SIZE USED.

OWNER, DEVELOPER, OR CONTRACTOR SHALL INSTALL CONDUIT WITH PULL ROPE. CONDUIT SIZE AND DEPTH, AND INSTALLATION DETAILS PER SERVING UTILITY REQUIREMENTS. OWNER SHALL FURNISH AN EASEMENT AS REQUIRED BY THE SERVING UTILITY.

5 TO 6 FOOT SIDEWALK

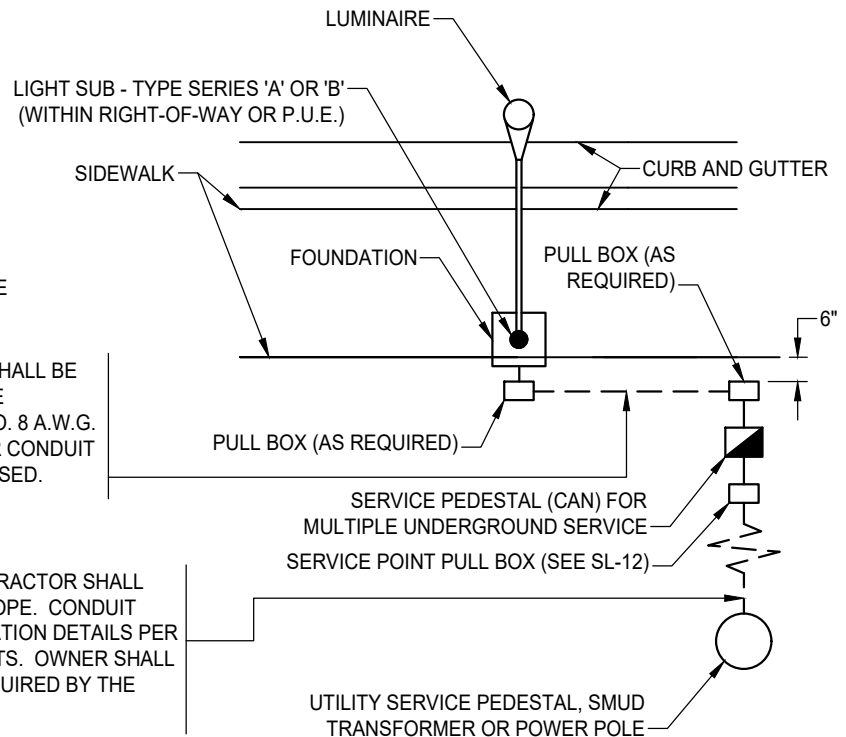

6 FOOT OR WIDER SIDEWALK

NOTES:

1. ALL CITY OWNED FACILITIES SHALL BE WITHIN RIGHT-OF-WAY (R/W) OR PUBLIC UTILITY EASEMENT (PUE).
2. SEE STANDARD DRAWING SL-12 FOR SERVICE POINT PULL BOX DETAILS AND WIRING DIAGRAM.
3. SEE STANDARD DRAWING SL-4 FOR PULL BOX DETAILS.
4. PHOTOCELLS SHALL BE INSTALLED ON THE TOP OF THE LUMINAIRE NEAREST THE SERVICE PEDESTAL OR SERVICE POINT.
5. THE SERVICING UTILITY WILL INSTALL AND MAINTAIN CONDUCTORS FROM THEIR TRANSFORMER, OR POWER POLE TO THE SERVICE POINT PULL BOX.
6. STREET LIGHT CIRCUITS SHALL HAVE A DEDICATED SERVICE METER AND SHALL NOT BE WIRED TO BYPASS THE METER.

DATE 09/22/2007		NOT TO SCALE	
REVISION	BY	APPROVED	DATE
01	STN	JRW	02/16/2021

CITY OF ELK GROVE - PUBLIC WORKS

**UNDERGROUND SERVICE
INSTALLATION**

APPROVED BY:

Robert M. Mudgett 02/26/2021
CITY ENGINEER DATE



DRAWING NUMBER

SL - 7

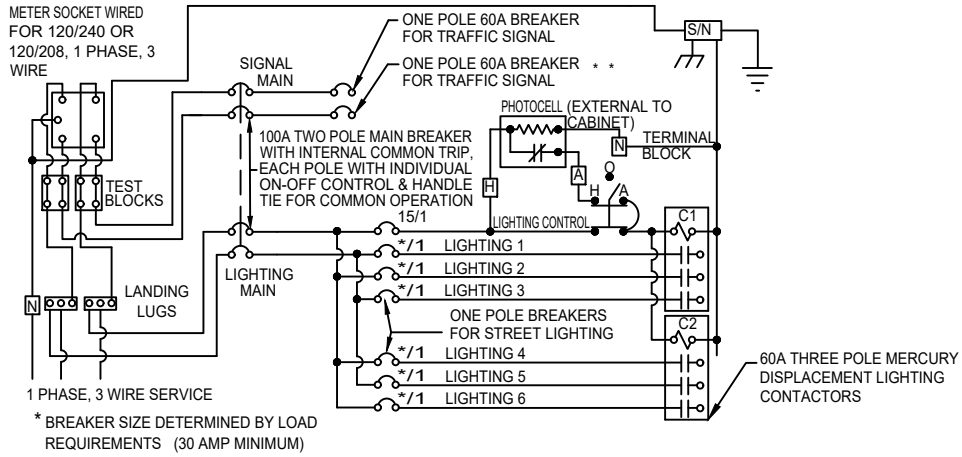
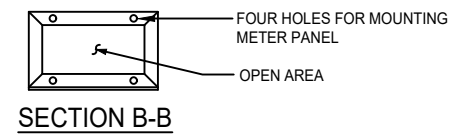
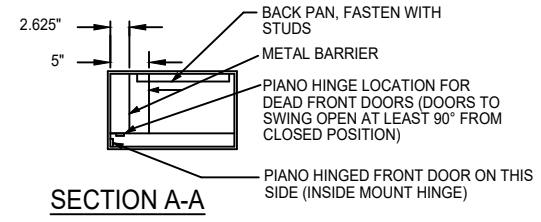
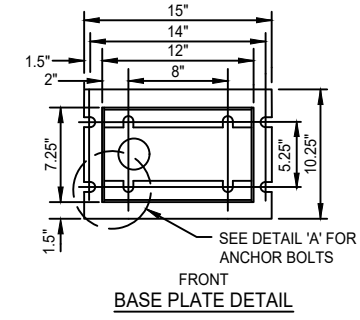
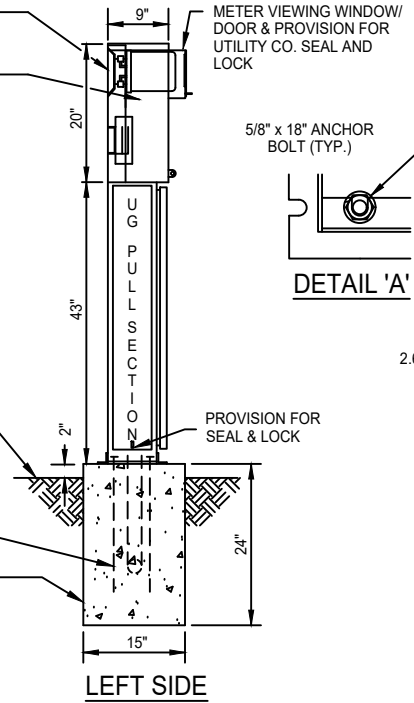
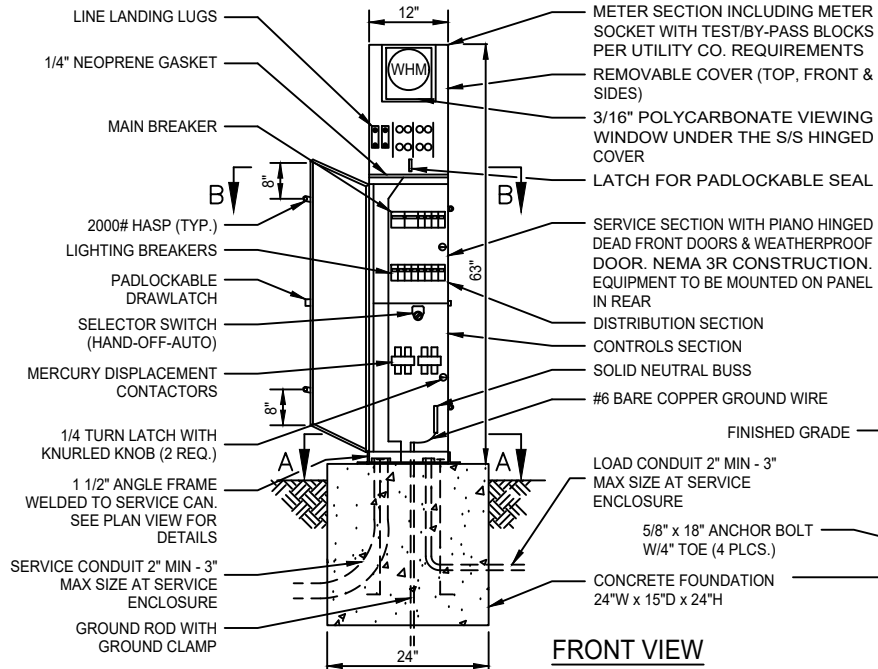

- NOTES:
- EXTERIOR SHALL BE 14 GAUGE #304D STAINLESS STEEL, INTERIOR DEAD FRONT PANEL AND BACK PAN SHALL BE 14 GAUGE STEEL, PAINTED WHITE. ENCLOSURE SHALL BE ELECTRICALLY WELDED AND REINFORCED WHERE REQUIRED.
 - CONSTRUCTION SHALL BE NEMA 3R AND 12, RAIN TIGHT AND DUST TIGHT.
 - ALL NUTS, BOLTS, SCREWS AND HINGES SHALL BE STAINLESS STEEL.
 - NUTS, BOLTS, AND SCREWS SHALL NOT BE USED ON THE OUTSIDE OF THE SERVICE ENCLOSURE.
 - PHENOLIC NAMEPLATES SHALL BE USED TO IDENTIFY ALL OPERATOR CONTROLS.
 - CONTROL WIRING SHALL BE MARKED AT BOTH ENDS BY PERMANENT WIRE MARKERS.
 - A PLASTIC COVERED WIRING DIAGRAM SHALL BE ATTACHED TO THE INSIDE OF THE FRONT DOOR.
 - SERVICE ENCLOSURE SHALL BE FACTORY WIRED AND CONFORM TO REQUIRED NEMA STANDARDS.
 - SERVICE ENCLOSURE SHALL BE U.L. LISTED AS INDUSTRIAL CONTROL PANELS U.L. 508 FILE NO. E62062.
 - WIRING BETWEEN CIRCUIT BREAKER AND CONTACTOR SHALL BE #6 THWN OR THHN MINIMUM.
 - SERVICE ENCLOSURE SHALL BE OF TWO-PIECE CONSTRUCTION.
 - THE WIRING SCHEMATIC DIAGRAM AS SHOWN IS FOR A 2-WIRE STREET LIGHTING SYSTEM. IF THE SERVICE ENCLOSURE WILL BE USED FOR A 3-WIRE STREET LIGHTING SYSTEM, THEN THE LIGHTING BREAKERS SHALL CONSIST OF 2-POLE BREAKERS WITH INTERNAL COMMON TRIP, EACH POLE WITH INDIVIDUAL ON-OFF CONTROL AND HANDLE TIE FOR COMMON OPERATION. FOR EACH 2-POLE BREAKER, THE CIRCUIT LOAD SHALL BE EQUALLY DIVIDED ACROSS THE LIGHTING MAIN.
 - SEE STANDARD SPECIFICATIONS FOR ADDITIONAL DETAILS.
 - DUAL METERS SHALL BE PROVIDED AND SHALL CONFORM TO CALTRANS STANDARD DRAWING ES-2F.
 - STREET LIGHT CIRCUITS SHALL HAVE A DEDICATED SERVICE METER AND SHALL NOT BE WIRED TO BYPASS THE METER.

METERED SERVICE WIRING SCHEMATIC DIAGRAM

** MODIFY TRAFFIC SIGNAL BREAKER TO PROVIDE A 15 AMP. 120V, 1P CIRCUIT BREAKER FOR IISNS. MODIFY WIRINGS TO USE 60 AMP. LIGHTING CONTACTOR FOR IISNS.

DATE		NOT TO SCALE	
09/22/2007			
REVISION	BY	APPROVED	DATE
01	STN	JRW	02/16/2021

CITY OF ELK GROVE - PUBLIC WORKS

METERED SERVICE PEDESTAL (Can) (120/208V, 120/240V)

APPROVED BY:

 CITY ENGINEER DATE 02/26/2021



DRAWING NUMBER
SL - 8

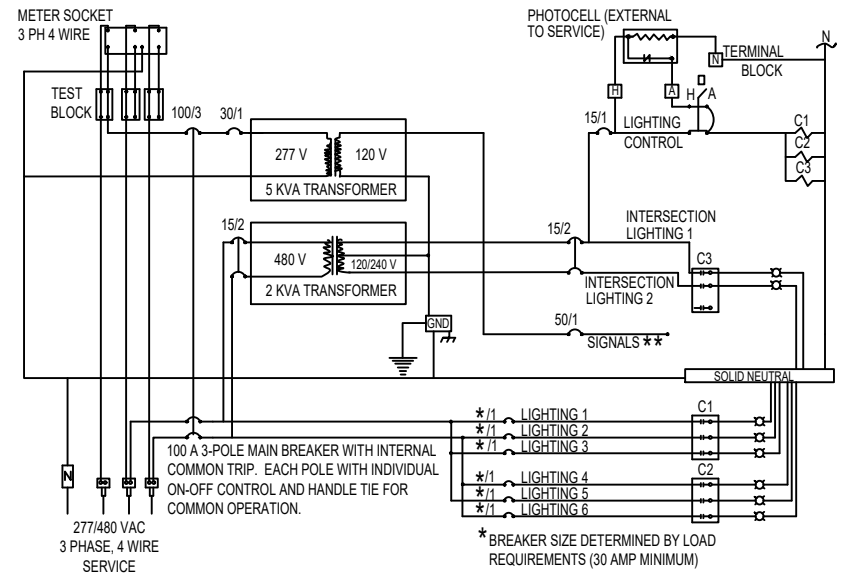
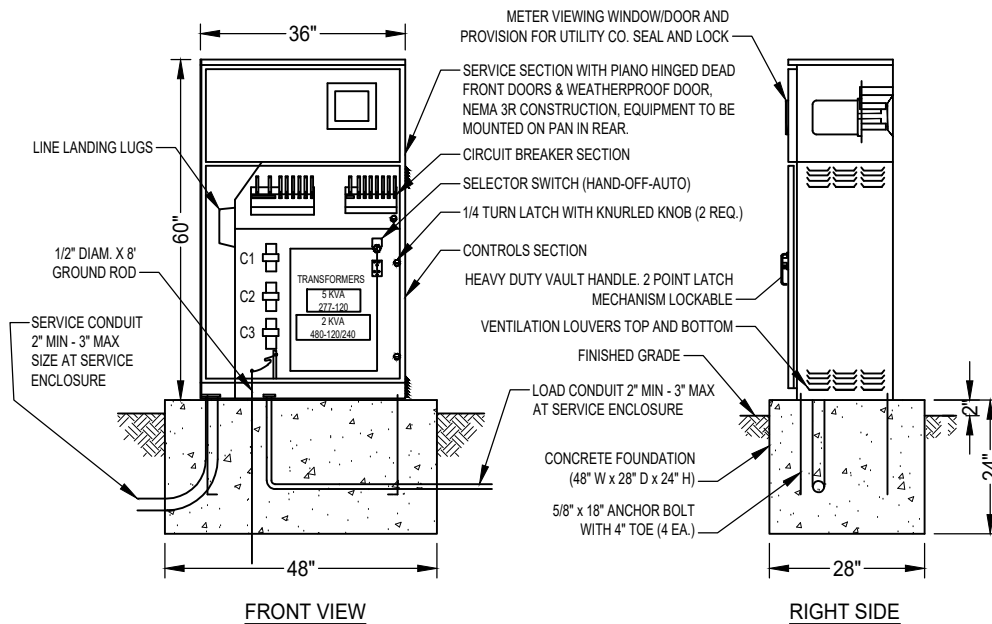

METERED SERVICE WIRING SCHEMATIC DIAGRAM

* BREAKER SIZE DETERMINED BY LOAD REQUIREMENTS (30 AMP MINIMUM)

** PROVIDE A 15 AMP, 120V, 1P CIRCUIT BREAKER FOR IISNS. MODIFY WIRINGS TO USE LIGHTING CONTACTOR FOR IISNS.

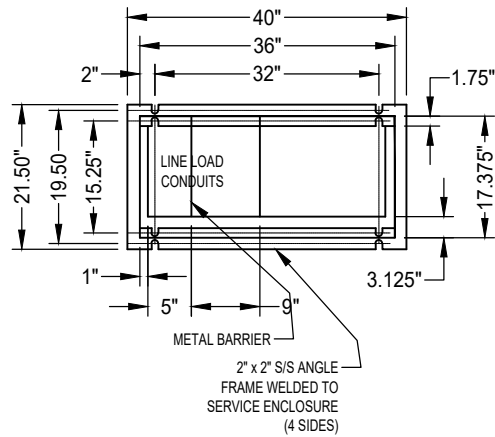

BASE PLATE DETAIL

NOTES:

- EXTERIOR SHALL BE 14 GAUGE #304D STAINLESS STEEL, INTERIOR SHALL BE 14 GAUGE STEEL, PAINTED WHITE. ENCLOSURE SHALL BE ELECTRICALLY WELDED AND REINFORCED WHERE REQUIRED.
- CONSTRUCTION SHALL BE NEMA 3R AND 12, RAIN TIGHT AND DUST TIGHT.
- ALL NUTS, BOLTS, SCREWS AND HINGES SHALL BE STAINLESS STEEL.
- NUTS, BOLTS, AND SCREWS SHALL NOT BE USED ON THE OUTSIDE OF THE SERVICE ENCLOSURE.
- PHENOLIC NAMEPLATES SHALL BE USED TO IDENTIFY ALL OPERATION CONTROLS.
- CONTROL WIRING SHALL BE MARKED AT BOTH ENDS BY PERMANENT WIRE MARKERS.
- A PLASTIC COVERED WIRING DIAGRAM SHALL BE ATTACHED TO THE INSIDE OF THE FRONT DOOR.
- SERVICE ENCLOSURE SHALL BE FACTORY WIRED AND CONFORM TO REQUIRED NEMA STANDARDS.
- SERVICE ENCLOSURE SHALL BE U.L. LISTED AS INDUSTRIAL CONTROL PANELS U.L. 508 FILE NO. E62062.
- WIRING BETWEEN CIRCUIT BREAKER AND CONTACTOR SHALL BE #6 THWN OR THHN MINIMUM.
- SIZE OF TRANSFORMER FOR SIGNALS SHALL BE 5 KVA. SIZE OF TRANSFORMER FOR 120 V INTERSECTION SHALL BE 2 KVA.
- WHEN CHANGING VOLTAGE ON A RETROFIT PROJECT WHERE A NEW SERVICE ENCLOSURE WITH A STEP-DOWN TRANSFORMER IS REQUIRED, THE NEW SERVICE ENCLOSURE THE NEW SERVICE ENCLOSURE SHALL BE PLACED BETWEEN THE SERVICE POINT AND THE OLD SERVICE ENCLOSURE LOCATION WITHIN THE CITY R/W. VOLTAGE OUTPUT FROM THE NEW SERVICE ENCLOSURE MAY BE CONNECTED INTO THE EXISTING CONDUIT SYSTEM.
- THE WIRING SCHEMATIC DIAGRAM AS SHOWN IS FOR A 2-WIRE STREET LIGHTING SYSTEM. IF THE SERVICE ENCLOSURE WILL BE USED FOR A 3-WIRE STREET LIGHTING SYSTEM, THEN THE LIGHTING BREAKERS SHALL CONSIST OF 2-POLE BREAKERS WITH INTERNAL COMMON TRIP, EACH POLE WITH INDIVIDUAL ON-OFF CONTROL AND HANDLE TIE FOR COMMON OPERATION. FOR EACH 2-POLE BREAKER, THE CIRCUIT LOAD SHALL BE EQUALLY DIVIDED ACROSS THE LIGHTING MAIN.
- SEE STANDARD SPECIFICATIONS FOR ADDITIONAL DETAILS.
- DUAL METERS SHALL BE PROVIDED AND SHALL CONFORM TO CALTRANS STANDARD DRAWING ES-2F.
- STREET LIGHT CIRCUITS SHALL HAVE A DEDICATED SERVICE METER AND SHALL NOT BE WIRED TO BYPASS THE METER.

DATE 09/22/2007		NOT TO SCALE	
REVISION	BY	APPROVED	DATE
01	STN	JRW	02/16/2021

CITY OF ELK GROVE - PUBLIC WORKS

**METERED SERVICE PEDESTAL (Can)
WITH STEP-DOWN TRANSFORMER
(277/480V TO 120/240V)**

APPROVED BY:
Paul M. Mudgett
CITY ENGINEER

02/26/2021
DATE

DRAWING NUMBER
SL - 9



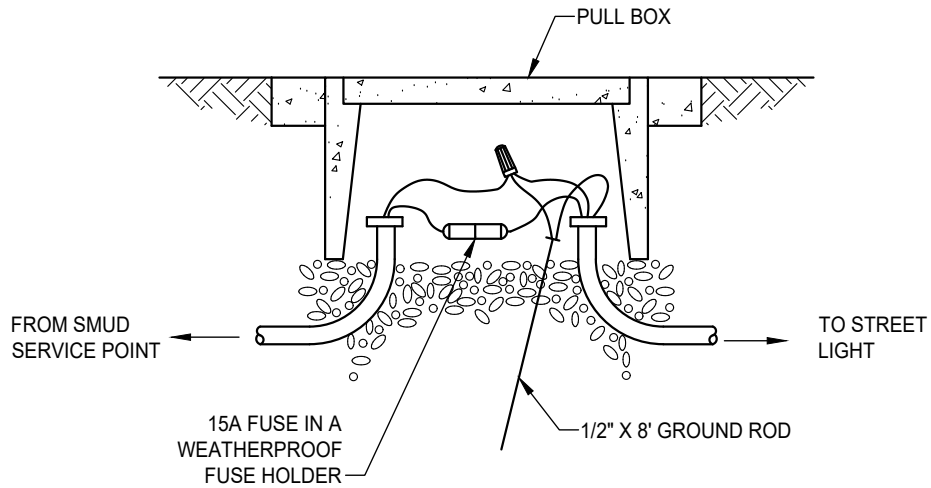

SERVICE POINT PULL BOX DETAILS

LAMP WATTAGE	ELECTROLIER FUSE SIZE
115 WATT OR LESS	2 AMP

NOTES:

1. FUSE SHALL BE A MIDGET FERRULE TYPE. RATED AT 600 VOLTS.
2. ATTACH GROUND CONDUCTOR TO THE ELECTROLIER.
3. ALL PULL BOXES SHALL HAVE PROVISIONS FOR LOCKING.

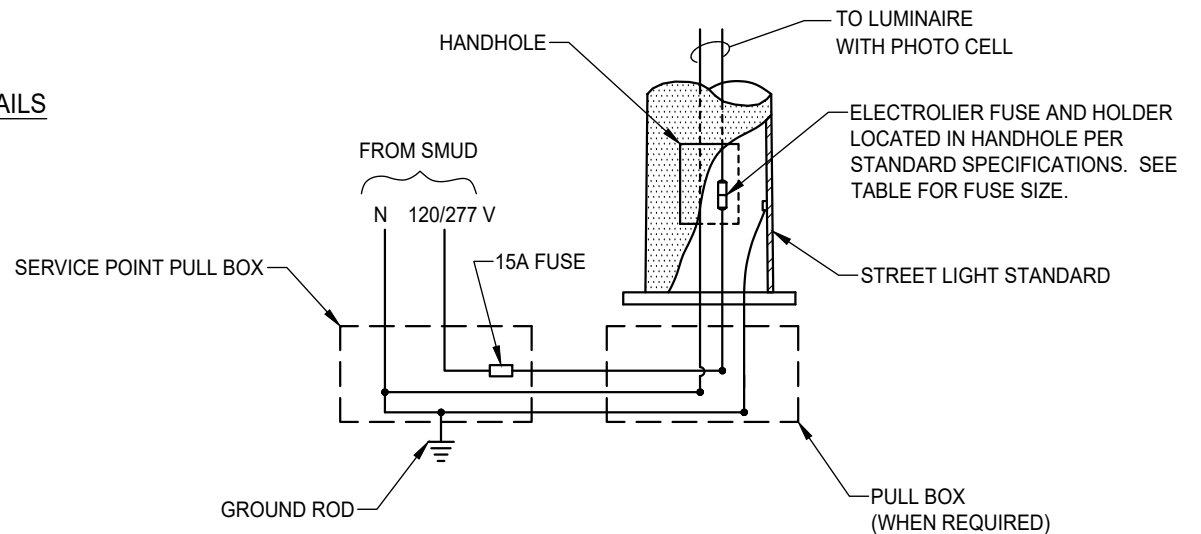

WIRING DIAGRAM

DATE: 09/22/2007		NOT TO SCALE	
REVISION	BY	APPROVED	DATE
1	SJB	SMA	03-25-2024

CITY OF ELK GROVE - PUBLIC WORKS

IN-LINE FUSE REQUIREMENTS

APPROVED BY:

[Signature] 05-28-2024

CITY ENGINEER

DATE



DRAWING NUMBER

SL - 12

TYPICAL VOLTAGE DROP CALCULATION FOR 2 - WIRE SYSTEM

$$\text{VOLTAGE DROP (COPPER CONDUCTOR)} = \frac{D \times A \times N \times 22}{\text{CIRCULAR MILS}}$$

D = Length of section, in feet.

A = Line operating amperes drawn by one light.

N = Number of lights in the circuit beyond the section.

WIRE SIZE (AWG)	AREA (Circular Mils)
14	4,110
12	6,530
10	10,380
8	16,510
6	26,250
4	41,740

Driver Maximum Input Amps for Light Emitting Diode (LED) Luminaires (At 115 Volts)
All Fixtures: 1.25 Amps

TYPICAL MULTIPLE STREET LIGHTING SYSTEM

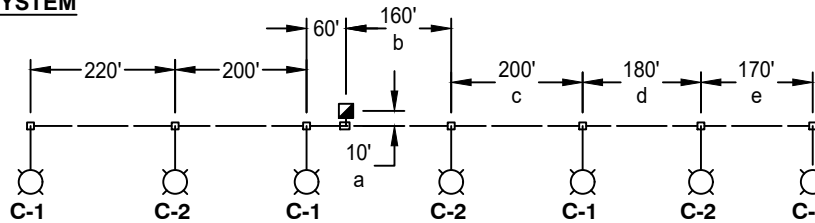

EXAMPLE CALCULATION:

FIND TOTAL VOLTAGE DROP IN CIRCUIT #1:
(115 volt system)

NOTE:

Dimension "a" is the distance between the service can and the adjacent load pull box. Use "a"=10' for standard installations where the load pull box is immediately adjacent to the service can.

Voltage drop calculations

$$\text{Section a} = \frac{10 (1.25 \times 4) (22)}{10,380} = 0.11$$

$$\text{Section b + c} = \frac{360 (1.25 \times 2) (22)}{10,380} = 1.91$$

$$\text{Section d + e} = \frac{350 (1.25 \times 1) (22)}{10,380} = 0.93$$

$$\text{TOTAL VOLTAGE DROP} = 2.95$$

LEGEND

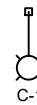

115W Light Emitting Diode Luminaire

Circuit #1



Service Can

Conduit with #10 AWG Conductors

NOTES:

- Design must be based on a two (2) wire system, even though three (3) wires (with a single common wire) are actually used.
- Maximum voltage drop allowed in 115 volt system = 8.05 volts.

DATE 09-22-2017		NOT TO SCALE	
REVISION	BY	APPROVED	DATE
01	STN	SA	06-20-2023

CITY OF ELK GROVE - PUBLIC WORKS

2 - WIRE STREET LIGHT SYSTEM WIRE SIZE AND VOLTAGE DROP CALCULATION

APPROVED BY:

Jeffrey B. Wan 06-21-2023
CITY ENGINEER DATE



DRAWING NUMBER

SL - 13

TYPICAL VOLTAGE DROP CALCULATION FOR 3 - WIRE SYSTEM

$$\text{VOLTAGE DROP (COPPER CONDUCTOR)} = \frac{D \times A \times N \times 11}{\text{CIRCULAR MILS}}$$

D = Length of section, in feet.

A = Line operating amperes drawn by one light.

N = Number of lights in the circuit beyond the section.

WIRE SIZE (AWG)	AREA (Circular Mils)
14	4,110
12	6,530
10	10,380
8	16,510
6	26,250
4	41,740

Driver Maximum Input Amps for Light Emitting Diode (LED) Luminaires (At 115 Volts)
All Fixtures: 1.25 Amps

TYPICAL MULTIPLE STREET LIGHTING SYSTEM

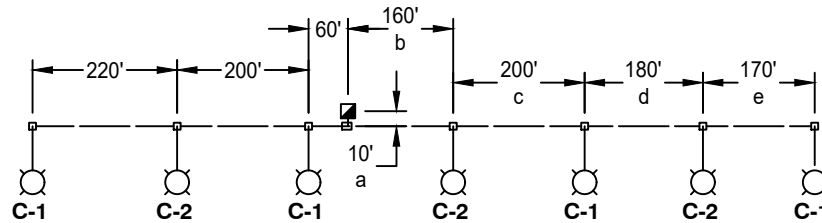





EXAMPLE CALCULATION:
FIND TOTAL VOLTAGE DROP IN CIRCUIT #1:
(115 volt system)

NOTE:

Dimension "a" is the distance between the service can and the adjacent load pull box. Use "a"=10' for standard installations where the load pull box is immediately adjacent to the service can.

LEGEND

-  115W Light Emitting Diode Luminaire
-  Circuit #1
-  Service Can
-  Conduit with #12 AWG Conductors

Voltage drop calculations

$$\text{Section a} = \frac{10 (1.25 \times 4) (11)}{6,530} = 0.08$$

$$\text{Section b} + \text{c} = \frac{360 (1.25 \times 2) (11)}{6,530} = 1.52$$

$$\text{Section d} + \text{e} = \frac{350 (1.25 \times 1) (11)}{6,530} = 0.74$$

$$\text{TOTAL VOLTAGE DROP} = 2.34$$

NOTES:

- Maximum voltage drop allowed in 115 volt system = 6.90 volts.

DATE 09-22-2017		NOT TO SCALE	
REVISION	BY	APPROVED	DATE
01	STN	SA	06-20-2023

CITY OF ELK GROVE - PUBLIC WORKS

3 - WIRE STREET LIGHT SYSTEM WIRE SIZE AND VOLTAGE DROP CALCULATION

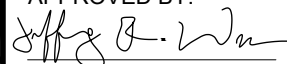
APPROVED BY:
 06-21-2023
CITY ENGINEER DATE

DRAWING NUMBER
SL - 14



CONDUIT SIZING

CONDUCTOR	EQUIVALENT NUMBER OF #14 AWG CONDUCTORS FOR USE IN CONDUIT SIZING
#12 CONDUCTOR	1.2
#10 CONDUCTOR	1.5
#8 CONDUCTOR	2.3
#6 CONDUCTOR	3
#4 CONDUCTOR	4
#2 CONDUCTOR	5.3
#0 CONDUCTOR	11.5
INTERCONNECT CABLE	18
DETECTOR LEAD-IN CABLE	2.5
EMERGENCY VEHICLE DETECTOR CABLE	2

CONDUIT SIZE	2"	2.5"	3"	3.5"	4"
MAXIMUM NUMBER OF #14 AWG CONDUCTORS	31	44	69	91	113

NOTE: MINIMUM SIZE FOR NEW CONDUITS IS 2.0".

SERVICE WIRE MAXIMUM LENGTHS FOR TRAFFIC SIGNALS

CIRCUIT BREAKER SIZING

CONDUCTOR SIZE (AWG)	MAXIMUM CIRCUIT BREAKER AMPERAGE
#2	100
#4	80
#6	50
#8	40
#10	30

WIRE SIZE	LENGTH
#0	576'
#2	360'
#4	224'

NOTE:

1. THE BREAKER SIZE SHALL BE DETERMINED BY THE LOAD REQUIREMENTS. MINIMUM BREAKER SIZE IS 15 AMPS.

DATE: 09/22/2017		NOT TO SCALE	
REVISION	BY	APPROVED	DATE
1	SJB	SMA	03-25-2024

CITY OF ELK GROVE - PUBLIC WORKS

**CONDUIT, SERVICE WIRE AND
BREAKER SIZING**

APPROVED BY:  05-28-2024
CITY ENGINEER DATE





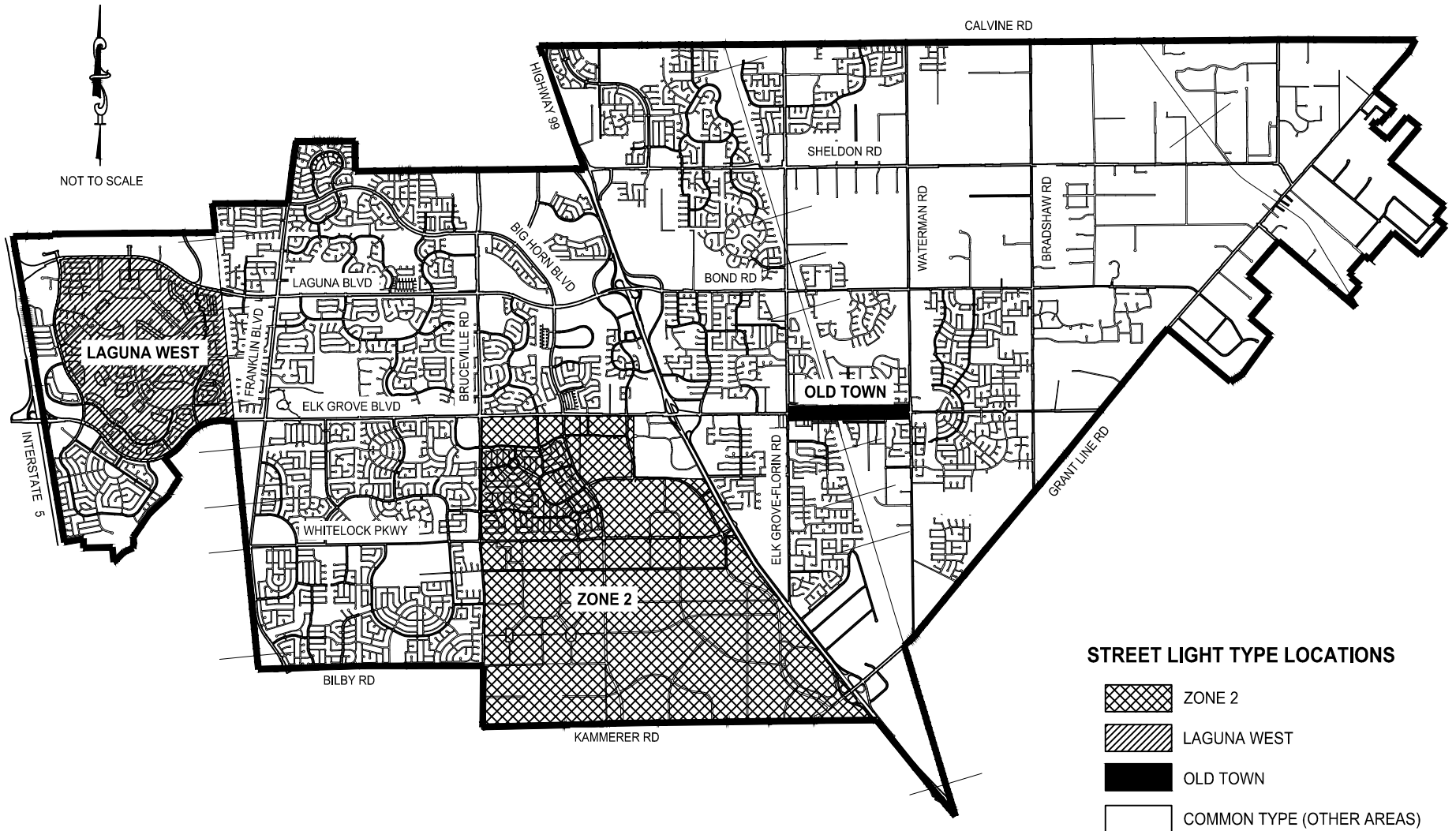

DRAWING NUMBER

SL - 15



STREET LIGHT TYPE LOCATIONS

-  ZONE 2
-  LAGUNA WEST
-  OLD TOWN
-  COMMON TYPE (OTHER AREAS)

DATE: 09/22/2007		NOT TO SCALE	
REVISION	BY	APPROVED	DATE

CITY OF ELK GROVE - PUBLIC WORKS

APPROVED BY:

 CITY ENGINEER 10/24/2018
DATE

STREET LIGHT AREAS

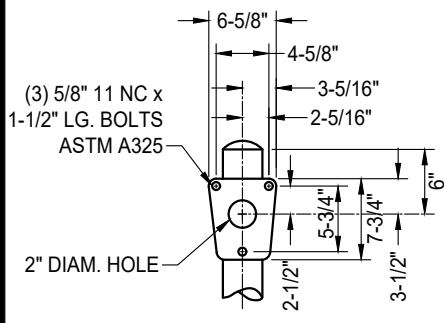

DRAWING NUMBER

SL - 19



LUMINAIRE ARM DETAILS

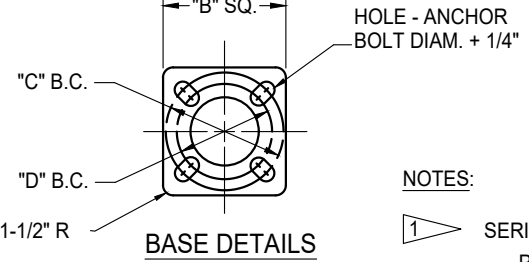
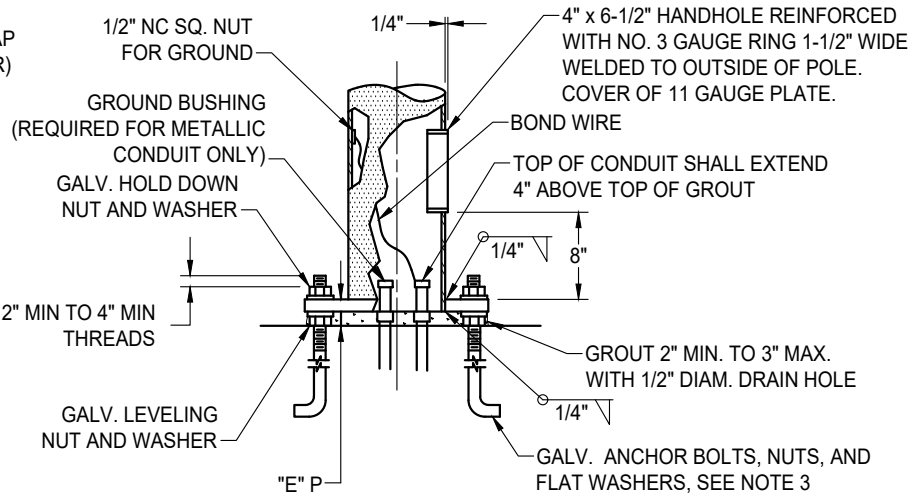
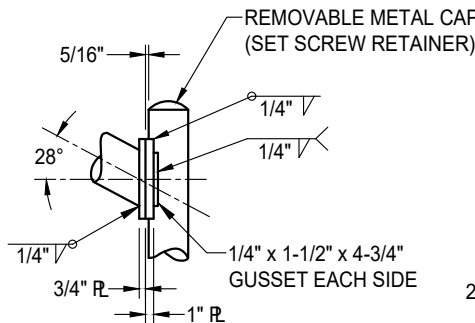

- NOTES:
- SERIES 'A' NUMBERING PROCEDURE
 POLE SIZE 'A' → A-286-8 → LUMINAIRE ARM SIZE 'F'
 (STANDARD UNLESS OTHERWISE SPECIFIED)
 - STANDARD SHALL BE INSTALLED SO HANDHOLE FACES THE STREET.
 - ANCHOR BOLT SIZES SHALL BE PURSUANT TO THE POLE MANUFACTURER'S DESIGN REQUIREMENTS, WHICH SHALL BE IN ACCORDANCE WITH AASHTO "STANDARD SPECIFICATIONS FOR STRUCTURAL SUPPORTS FOR HIGHWAY SIGNS, LUMINAIRES, AND TRAFFIC SIGNALS."

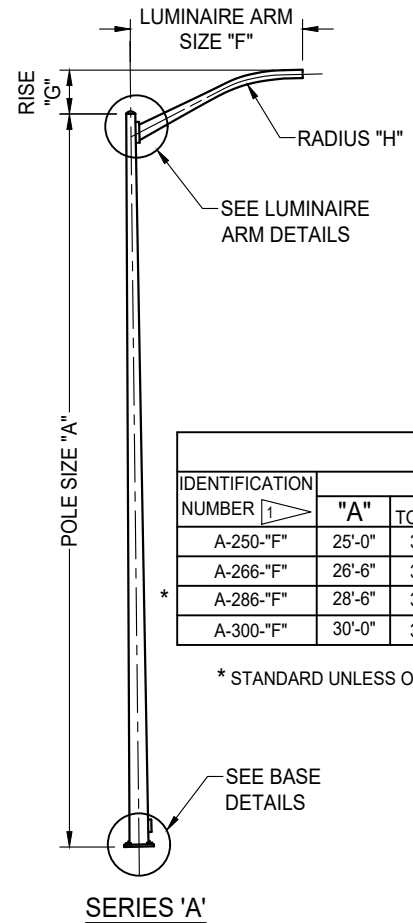

FOUNDATION DIMENSIONS		
	SQUARE	ROUND
SERIES 'A'	2'6" x 2'6" x 5'	2'6" x 6'6"

LUMINAIRE ARM DATA						
"F"	END OD	BASE OD	GA	"G"	"H"	
6'-0"	2-3/8"	3-3/8"	10	1'-6"	7'-5"	
* 8'-0"	2-3/8"	3-11/16"	10	2'-3"	7'-5"	
10'-0"	2-3/8"	3-7/8"	10	2'-6"	13'-3"	
12'-0"	2-3/8"	4-5/16"	10	3'-9"	13'-3"	
15'-0"	2-3/8"	4-3/4"	10	4'-3"	13'-3"	
18'-0"	2-3/8"	4-3/4"	10	5'-3"	13'-3"	

'A' SERIES									
IDENTIFICATION NUMBER	POLE DATA				BASE PLATE DATA				ANCHOR BOLTS
	"A"	TOP OD	BASE OD	GA	"B"	"C"	"D"	"E"	
A-250-"F"	25'-0"	3-7/8"	7-5/16"	11	12"	11-1/2"	11"	1"	SEE NOTE 3
A-266-"F"	26'-6"	3-7/8"	7-1/2"	11	12"	11-1/2"	11"	1"	
* A-286-"F"	28'-6"	3-7/8"	7-3/4"	11	12"	11-1/2"	11"	1"	
A-300-"F"	30'-0"	3-7/8"	8"	11	12"	11-1/2"	11"	1"	

* STANDARD UNLESS OTHERWISE SPECIFIED

DATE 09/22/2007		NOT TO SCALE	
REVISION	BY	APPROVED	DATE
01	STN	JRW	02/16/2021

CITY OF ELK GROVE - PUBLIC WORKS

COMMON TYPE ELECTROLIER (SERIES 'A')

APPROVED BY:

 02/26/2021
 CITY ENGINEER DATE

DRAWING NUMBER
SL - 20

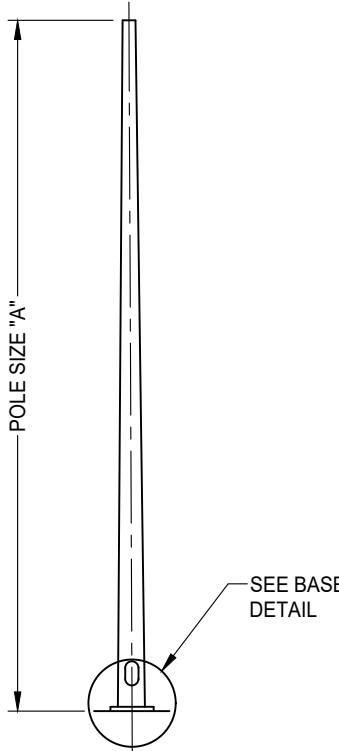
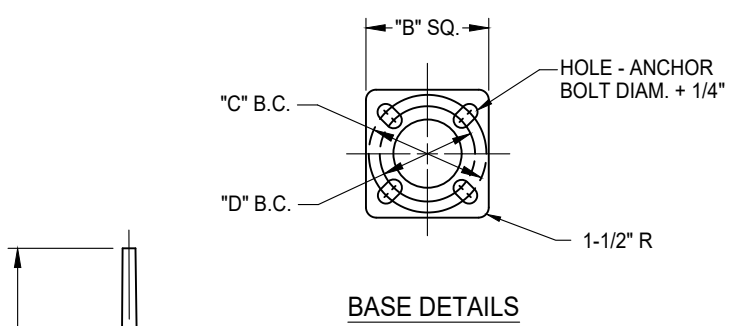

FOUNDATION DIMENSIONS		
	SQUARE	ROUND
SERIES 'B'	2' x 2' x 4'	2'6" x 3'6" or 2' x 4'

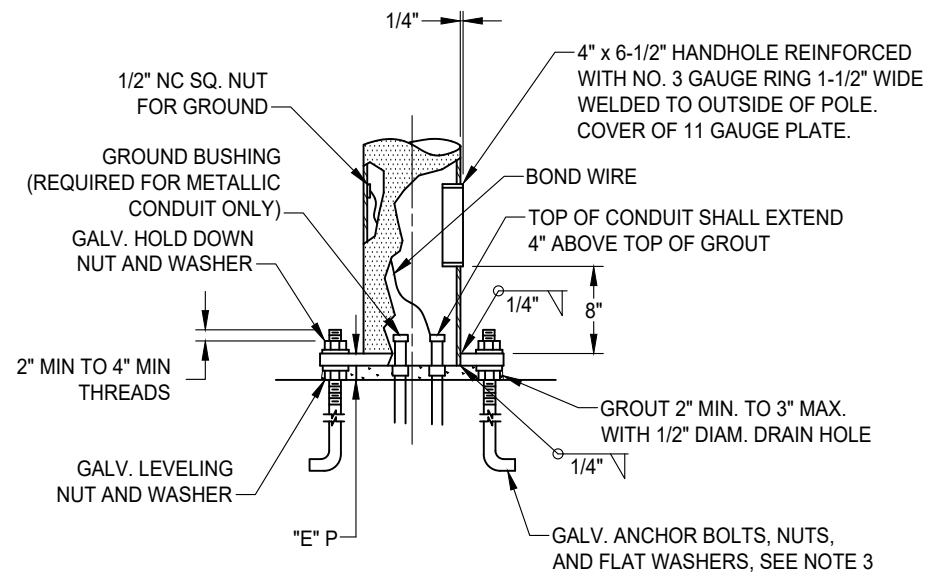

'B' SERIES									
POLE DATA					BASE PLATE DATA				ANCHOR BOLTS
"A"	TOP OD	BASE OD		GAUGE	"B"	"C"	"D"	"E"	
20'-0"	2-7/8"	MIN 5.61"	MAX 5.85"	10	10"	9-1/2"	9"	1"	NOTE 3

- NOTES:**
- STANDARD SHALL BE INSTALLED SO HANDHOLE FACES THE STREET.
 - FOR USE IN ALL IN-FILL PROJECTS EAST OF HIGHWAY 99 OR NORTH OF ELK GROVE BLVD AND WEST OF HIGHWAY 99.
 - ANCHOR BOLTS SIZES SHALL BE PURSUANT TO THE POLE MANUFACTURER'S DESIGN REQUIREMENTS, WHICH SHALL BE IN ACCORDANCE WITH AASHTO "STANDARD SPECIFICATIONS FOR STRUCTURAL SUPPORTS FOR HIGHWAY SIGNS, LUMINAIRES, AND TRAFFIC SIGNALS."

DATE 09/22/2007		NOT TO SCALE	
REVISION	BY	APPROVED	DATE
01	STN	JRW	02/16/2021

CITY OF ELK GROVE - PUBLIC WORKS

**COMMON TYPE ELECTROLIER
(SERIES 'B')**

APPROVED BY:

Paul M. Mueloch 02/26/2021

CITY ENGINEER DATE

DRAWING NUMBER

SL - 22



STREET CLASSIFICATION	RIGHT - OF - WAY WIDTH	STREET LIGHT SUB-TYPE (SERIES)	STANDARD MOUNTING HEIGHT	MAXIMUM SPACING** (ONE SIDE ONLY)
MAJOR ARTERIAL	96'	A	30' - 9"	220'
MINOR ARTERIAL	74'	A	30' - 9"	220'
				MAXIMUM SPACING** (TWO-SIDES)
COLLECTOR	50'	B	21'	180'
PRIMARY RESIDENTIAL	40'	B	21'	200'
MINOR RESIDENTIAL	44'	B	21'	240'

NOTES:

1. WATTAGE AND MODEL NUMBER FOR LIGHT EMITTING DIODE (LED) LAMP SHALL BE SPECIFIED ON THE PLANS. EQUIPMENT SHALL CONFORM TO CITY OF ELK GROVE APPROVED EQUIPMENT LIST.
2. ILLUMINATION SHALL CONFORM TO STANDARD DRAWING SL-2.
3. SEE SECTION 5-8D OF THE CITY IMPROVEMENT STANDARDS, "SPACING," FOR DEFINITIONS OF ONE-SIDE AND TWO-SIDE SPACING.
- *4. SINGLE FAMILY AND DUPLEX FAMILY ZONING SHALL USE SERIES 'B' STREET LIGHT, 21' MOUNTING HEIGHT, AND 180' SPACING.
- **5. MAXIMUM SPACING MAY BE ADJUSTED AS LONG AS ILLUMINATION CRITERIA ARE MET WITH APPROVAL OF THE ENGINEER.

DATE 09/22/2017		NOT TO SCALE	
REVISION	BY	APPROVED	DATE
1	SJB	SMA	03-07-2025

CITY OF ELK GROVE - PUBLIC WORKS

**COMMON TYPE STREET LIGHT POLE
SPACING GUIDE
(SERIES 'A' / SERIES 'B')**

APPROVED BY: _____ 03-12-2025
CITY ENGINEER DATE

DRAWING NUMBER
SL - 24



STREET LIGHT PLACEMENT ON MAJOR ARTERIAL AND MINOR ARTERIAL STREETS (96' AND 74' STREETS)

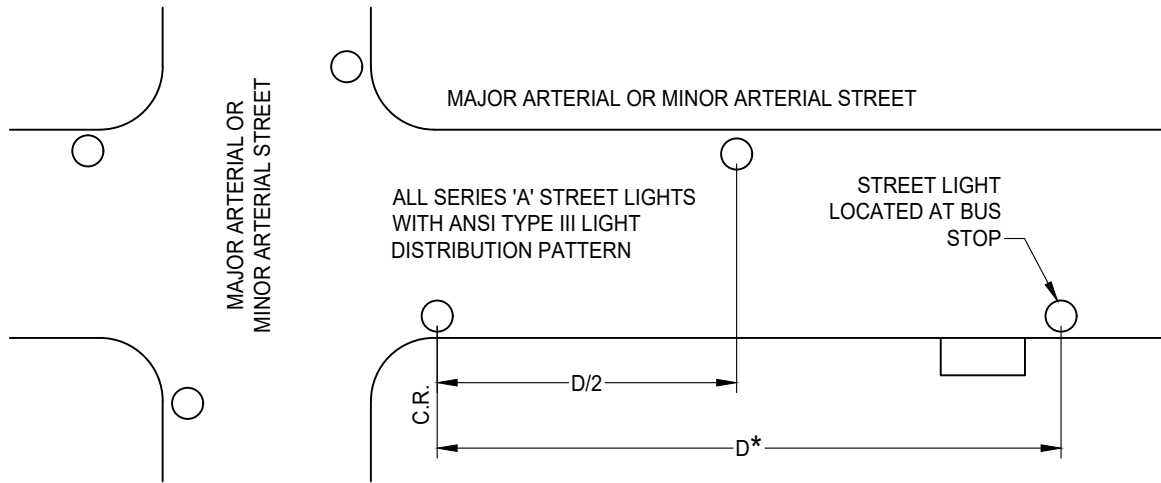

*SEE STANDARD DRAWING SL-24
D = 180' FOR 130' STREETS
D = 220' FOR 74' STREETS AND 96' STREETS

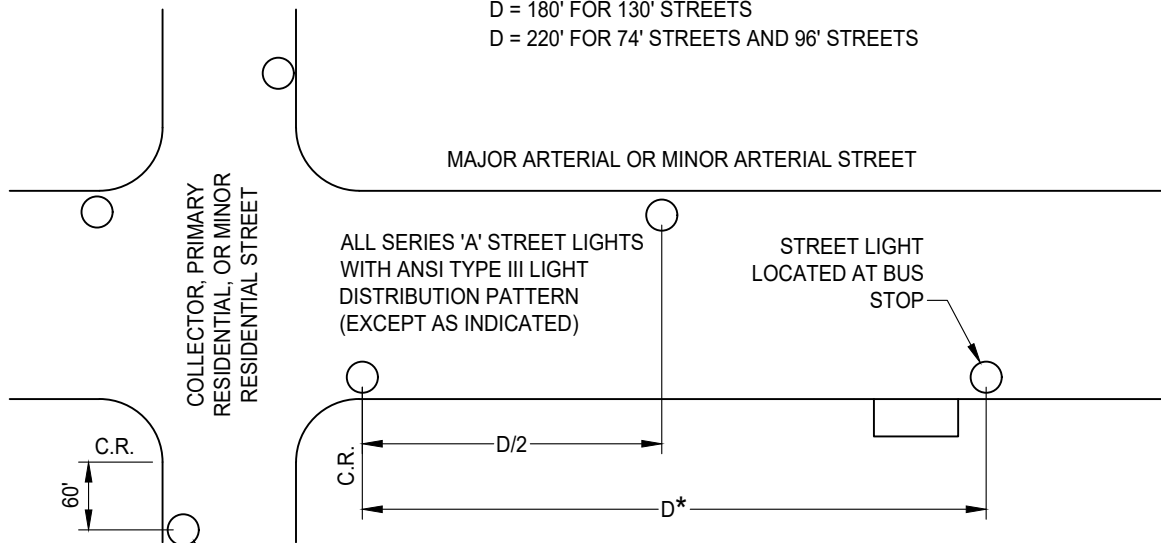

IN ACCORDANCE WITH STREET CLASSIFICATION, SERIES 'A' OR SERIES 'B' STREET LIGHT WITH ANSI TYPE III LIGHT DISTRIBUTION PATTERN. (SEE STANDARD DRAWINGS SL-2 AND SL-24)

DATE 09/22/2017		NOT TO SCALE	
REVISION	BY	APPROVED	DATE
1	SJB	SMA	03-07-2025

CITY OF ELK GROVE - PUBLIC WORKS

**COMMON TYPE TYPICAL LOCATIONS
ARTERIAL STREETS
(SERIES 'A'/ SERIES 'B')**

APPROVED BY: _____
03-12-2025
DATE

CITY ENGINEER DATE

DRAWING NUMBER
SL - 25



**STREET LIGHT PLACEMENT
ON COLLECTOR, PRIMARY RESIDENTIAL, AND
MINOR RESIDENTIAL STREETS
(ALL STREETS OTHER THAN 96' AND 74' STREETS)**

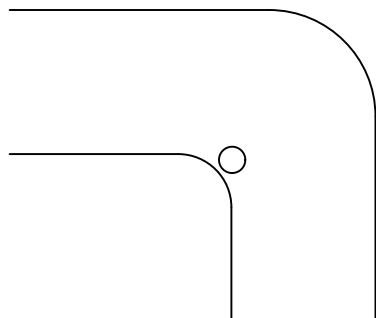
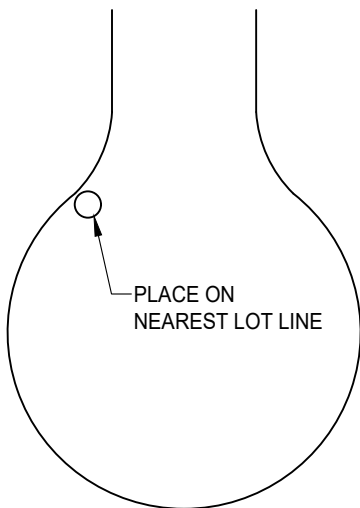
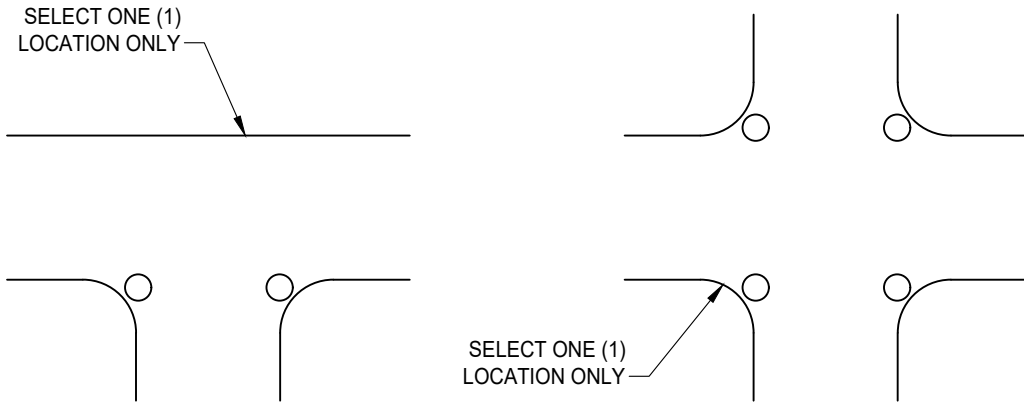

NOTE:

1. IN ACCORDANCE WITH STREET CLASSIFICATIONS, ALL ARE SERIES 'A' OR SERIES 'B' STREET LIGHTS WITH ANSI TYPE III LIGHT DISTRIBUTIONS PATTERN. SEE STANDARD DRAWINGS SL-2 AND SL-24

DATE: 09/22/2017		NOT TO SCALE	
REVISION	BY	APPROVED	DATE
1	SJB	SMA	03-07-2025

CITY OF ELK GROVE - PUBLIC WORKS

**COMMON TYPE TYPICAL LOCATIONS
COLLECTOR AND RESIDENTIAL STREETS
(SERIES 'A' / SERIES 'B')**

APPROVED BY: _____ 03-12-2025
CITY ENGINEER DATE

DRAWING NUMBER
SL - 26



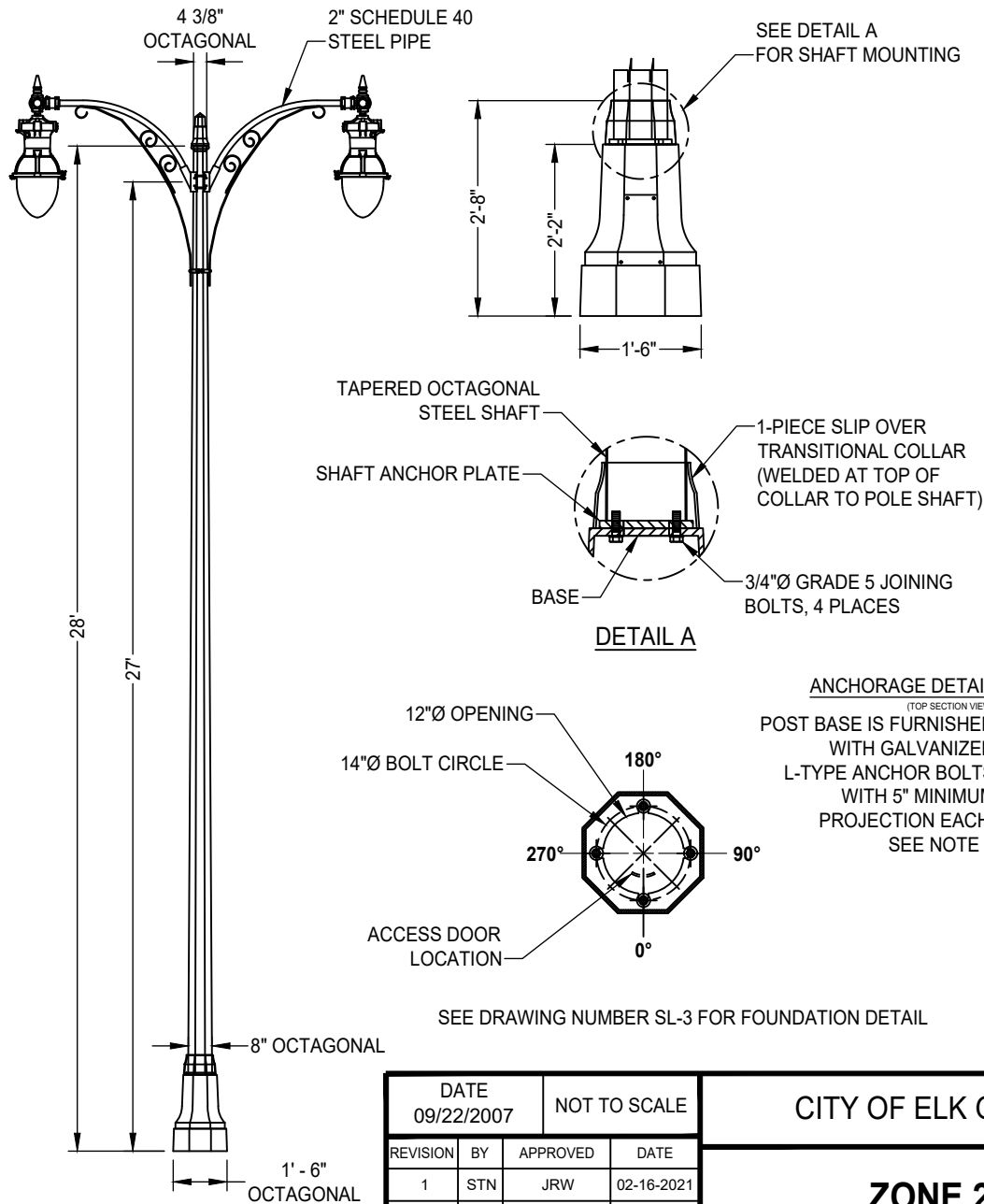

APPLICATION:

WIDE MEDIANS ON ARTERIALS AND THOROUGHFARES

SPECIFICATIONS:

POST BASE

THE BASE SHALL BE CAST IRON CONSTRUCTION WITH A TAPERED AND STEPPED OCTAGONAL PATTERN. A 1-PIECE SLIP OVER TRANSITION COLLAR COVERS THE BASE OF THE SHAFT. A DOOR IS LOCATED IN THE BASE FOR ANCHORAGE AND WIRING ACCESS. A GROUND SCREW (5/8") SHALL BE PROVIDED INSIDE THE BASE, OPPOSITE THE ACCESS DOOR.

POST SHAFT

THE POST SHAFT SHALL BE 11-GAUGE STEEL WITH A STEEL PLATE FOR MOUNTING TO THE BASE. THE OCTAGONAL SHAFT TAPERS FROM 8" (FLAT TO FLAT) AT THE BOTTOM TO 4-3/8" AT THE TOP, WITH A DECORATIVE OCTAGONAL FINIAL.

CROSSARM

THE CLAMP ON CROSSARM SHALL BE STEEL PIPE CONSTRUCTION WITH FLAT BAR SCROLLS AND 1-1/2" X 1/2" FLAT BAR CLAMP-ON BRACE. A SLEEVE GASKET SHALL BE INSTALLED TO PREVENT ARM MOVEMENT. ARMS SHALL HAVE A 2" PIPE SLEEVE FOR LUMINAIRE MOUNTING. THE CROSSARM MEASURES 52" FROM POST TO LUMINAIRE CENTERS. A LUMINAIRE LEVELING FITTER SHALL BE MOUNTED TO THE END OF THE PIPE ARM FOR LUMINAIRE MOUNTING. FIXTURE MOUNT TO CROSSARM SHALL BE HOLOPHANE WEST LIBERTY STYLE, QSM, OR EQUIVALENT. THREADED FIXTURE MOUNTS SHALL NOT BE ALLOWED.

FINISH

THE POST SHALL BE SHIPPED FINISHED WITH A STANDARD BLACK POWDER COAT FINISH.

NOTES:

1. ALL HARDWARE STAINLESS STEEL. ALL EXTERIOR HARDWARE TAMPER RESISTANT. BASE AND SHAFT TO BE SHIPPED AS A ONE-PIECE UNIT.
2. POLES AND LIGHTING EQUIPMENT SHALL CONFORM TO CITY OF ELK GROVE AUTHORIZED MATERIALS LIST
3. ANCHOR BOLT SIZES SHALL BE PURSUANT TO THE POLE MANUFACTURER'S DESIGN REQUIREMENTS, WHICH SHALL BE IN ACCORDANCE WITH AASHTO "STANDARD SPECIFICATIONS FOR STRUCTURAL SUPPORTS FOR HIGHWAY SIGNS, LUMINAIRES, AND TRAFFIC SIGNALS."

DATE 09/22/2007		NOT TO SCALE	
REVISION	BY	APPROVED	DATE
1	STN	JRW	02-16-2021
2	SJB	SMA	06-18-2025

CITY OF ELK GROVE - PUBLIC WORKS

APPROVED BY:

[Signature] 06-20-2025

CITY ENGINEER

DATE

**ZONE 2 ELECTROLIER
(DUAL ARM)**



DRAWING NUMBER

SL - 30

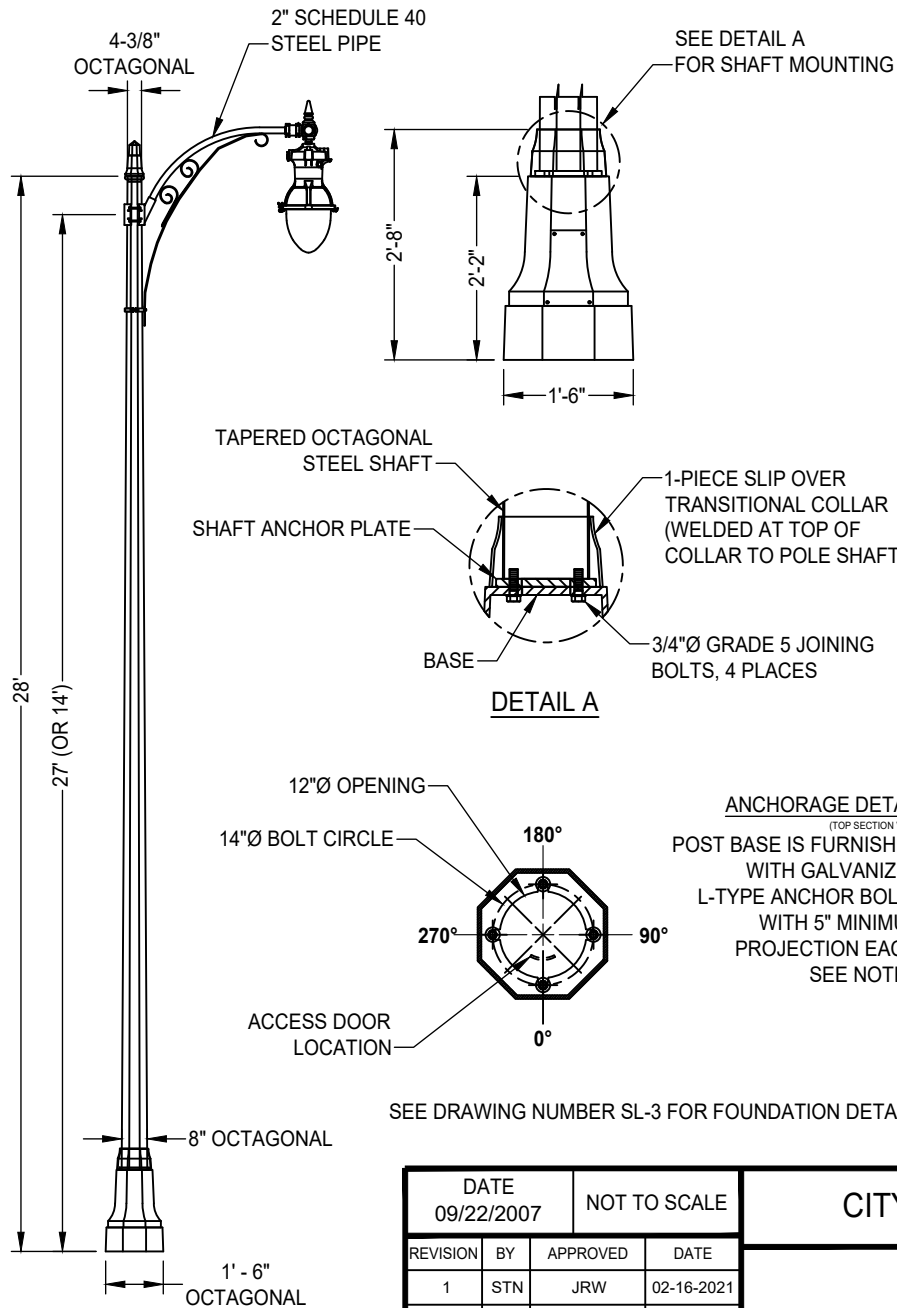

APPLICATION:

ARTERIAL (REDUCED MEDIAN) AND COLLECTOR STREETS

SPECIFICATIONS:

POST BASE

THE BASE SHALL BE CAST IRON CONSTRUCTION WITH A TAPERED AND STEPPED OCTAGONAL PATTERN. A 1-PIECE SLIP OVER TRANSITION COLLAR COVERS THE BASE OF THE SHAFT. A DOOR IS LOCATED IN THE BASE FOR ANCHORAGE AND WIRING ACCESS. A GROUND SCREW (5/8") SHALL BE PROVIDED INSIDE THE BASE, OPPOSITE THE ACCESS DOOR.

POST SHAFT

THE POST SHAFT SHALL BE 11-GAUGE STEEL WITH A STEEL PLATE FOR MOUNTING TO THE BASE. THE OCTAGONAL SHAFT TAPERS FROM 8" (FLAT TO FLAT) AT THE BOTTOM TO 4-3/8" AT THE TOP, WITH A DECORATIVE OCTAGONAL FINIAL.

CROSSARM

THE CLAMP ON CROSSARM SHALL BE STEEL PIPE CONSTRUCTION WITH FLAT BAR SCROLLS AND 1-1/2" X 1/2" FLAT BAR CLAMP-ON BRACE. A SLEEVE GASKET SHALL BE INSTALLED TO PREVENT ARM MOVEMENT. ARMS SHALL HAVE A 2" PIPE SLEEVE FOR LUMINAIRE MOUNTING. THE CROSSARM MEASURES 52" FROM POST TO LUMINAIRE CENTERS. A LUMINAIRE LEVELING FITTER SHALL BE MOUNTED TO THE END OF THE PIPE ARM FOR LUMINAIRE MOUNTING. FIXTURE MOUNT TO CROSSARM SHALL BE HOLOPHANE WEST LIBERTY STYLE, QSM, OR EQUIVALENT. THREADED FIXTURE MOUNTS SHALL NOT BE ALLOWED.

FINISH

THE POST SHALL BE SHIPPED FINISHED WITH A STANDARD BLACK POWDER COAT FINISH.

NOTES:

1. ALL HARDWARE STAINLESS STEEL. ALL EXTERIOR HARDWARE TAMPER RESISTANT. BASE AND SHAFT TO BE SHIPPED AS A ONE-PIECE UNIT.
2. POLES AND LIGHTING EQUIPMENT SHALL BE LISTED ON THE AUTHORIZED MATERIALS LIST.
3. ANCHOR BOLT SIZES SHALL BE PURSUANT TO THE POLE MANUFACTURUR'S DESIGN REQUIREMENTS. WHICH SHALL BE IN ACCORDANCE WITH AASHTO "STANDARD SPECIFICATIONS FOR STRUCTURAL SUPPORTS FOR HIGHWAY SIGNS, LUMINAIRES, AND TRAFFIC SIGNALS."

DATE 09/22/2007		NOT TO SCALE	
REVISION	BY	APPROVED	DATE
1	STN	JRW	02-16-2021
2	SJB	SMA	06-18-2025

CITY OF ELK GROVE - PUBLIC WORKS

APPROVED BY:

[Signature] 06-20-2025

CITY ENGINEER

DATE

**ZONE 2 ELECTROLIER
(SERIES 'A')**



DRAWING NUMBER

SL - 31

TEARDROP GLASS

ASYMMETRIC

STANDARD

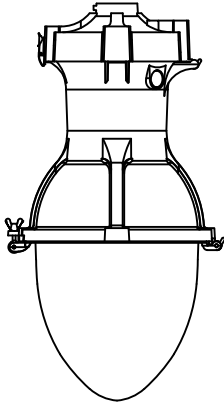

SHALLOW SKIRT*

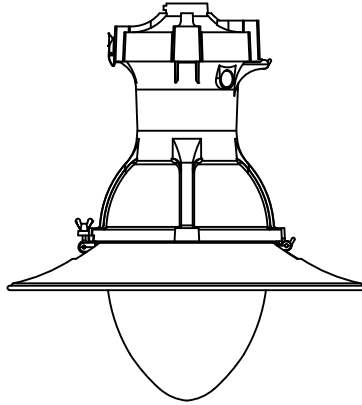

DEEP SKIRT*

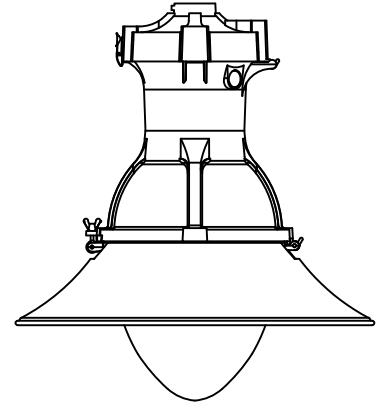

*OPTIONAL UPON WRITTEN APPROVAL OF CITY ENGINEER

SKIRT DIMENSIONS (OPTIONAL)

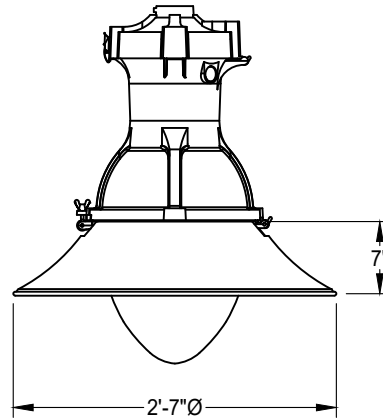
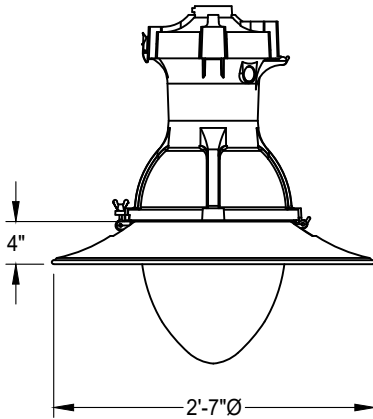

NOTE:

1. FIXTURE MOUNT TO CROSSARM SHALL BE HOLOPHONE WEST LIBERTY STYLE, QSM, OR EQUIVALENT. THREADED FIXTURE MOUNTS SHALL NOT BE ALLOWED.

DATE: 09/22/2017		NOT TO SCALE	
REVISION	BY	APPROVED	DATE
1	SJB	SMA	06-18-2025

CITY OF ELK GROVE - PUBLIC WORKS

**ZONE 2 LUMINAIRE OPTIONS
(SERIES 'A')**

APPROVED BY:  06-20-2025
 CITY ENGINEER DATE

DRAWING NUMBER
SL - 33



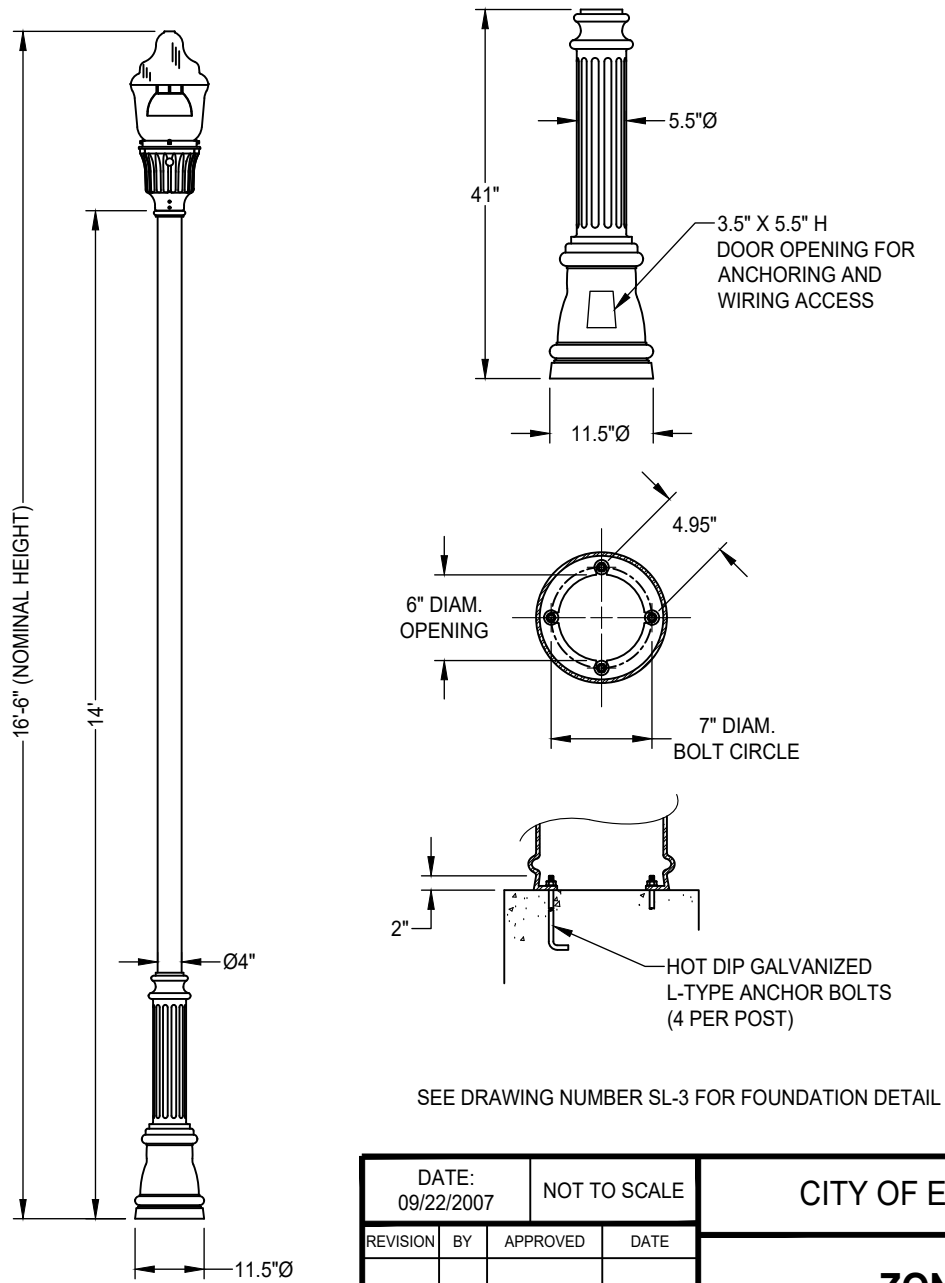

APPLICATION:

PEDESTRIAN TRAILS AND RESIDENTIAL STREETS

SPECIFICATIONS:

POST DESCRIPTION

THE LIGHTING POST SHALL BE ALL ALUMINUM, ONE-PIECE CONSTRUCTION, WITH A CLASSIC FLUTED BASE DESIGN. THE SHAFT SHALL BE Ø4" SMOOTH. THE POST SHALL BE SHIPPED WITH BLACK POWDER COAT FINISH.

MATERIALS

THE BASE SHALL BE HEAVY WALL, CAST ALUMINUM PRODUCED FROM CERTIFIED ASTM 356.1 INGOT PER ASTM B-179-95A OR ASTM B26-95. THE STRAIGHT SHAFTS SHALL BE EXTRUDED FROM ALUMINUM, ASTM 6061 ALLOY, HEAT TREATED TO A T6 TEMPER. ALL HARDWARE SHALL BE TAMPER RESISTANT STAINLESS STEEL. ANCHOR BOLTS TO BE COMPLETELY HOT DIP GALVANIZED.

CONSTRUCTION

THE SHAFT SHALL BE DOUBLE WELDED TO THE BASE CASTING AND SHIPPED AS ONE PIECE FOR MAXIMUM STRUCTURAL INTEGRITY. THE SHAFT SHALL BE CIRCUMFERENTIALLY WELDED INSIDE THE BASE CASTING AT THE TOP OF THE ACCESS DOOR, AND EXTERNALLY WHERE THE SHAFT EXITS THE BASE. ALL EXPOSED WELDS BELOW 8' SHALL BE GROUND SMOOTH. ALL WELDING SHALL BE PER ANSI/AWS D1.2-90. ALL WELDERS SHALL BE CERTIFIED PER SECTION 5 OF ANSI/AWS D1.2-90.

DIMENSIONS

THE POST SHALL BE 14' IN HEIGHT WITH AN 11-1/2" DIAMETER BASE. THE SHAFT DIAMETER SHALL BE 4". AT THE TOP OF THE POST, AN INTEGRAL 3" O.D. TENON WITH A TRANSITIONAL DONUT SHALL BE PROVIDED FOR LUMINAIRE MOUNTING.

INSTALLATION

THE POST SHALL BE PROVIDED WITH FOUR, HOT DIP GALVANIZED L-TYPE ANCHOR BOLTS TO BE INSTALLED ON AN 7" DIAMETER BOLT CIRCLE. A DOOR SHALL BE PROVIDED IN THE BASE FOR ANCHORAGE AND WIRING ACCESS. A GROUNDING SCREW (5/8") SHALL BE PROVIDED INSIDE THE BASE OPPOSITE THE DOOR.

NOTES:

1. POLES AND LIGHTING EQUIPMENT SHALL BE LISTED ON THE AUTHORIZED MATERIALS LIST.

DATE: 09/22/2007		NOT TO SCALE	
REVISION	BY	APPROVED	DATE

CITY OF ELK GROVE - PUBLIC WORKS

APPROVED BY:

Paul Murock

10/24/2018

CITY ENGINEER

DATE

**ZONE 2 ELECTROLIER
(SERIES 'B')**



DRAWING NUMBER

SL-34

STREET CLASSIFICATION	NUMBER OF LANE	STREET LIGHT SUB-TYPE (SERIES)	STANDARD POLE HEIGHT	MEDIAN	NO MEDIAN (SERIES 'A') (BOTH SIDES)
				MAXIMUM SPACING ("D") (FEET)	
SPECIAL THOROUGHFARE	8	DUAL ARM	28'	160	160
THOROUGHFARE	6	DUAL ARM	28'	160	160
ARTERIAL	2 - 4	DUAL ARM	28'	180	180
SPACING (BOTH SIDES) (FEET)					
COLLECTOR	2, 3	SERIES 'A**	28'	180	
	2, 3	SERIES 'B**	14'	150	
	2	SERIES 'A***	28'	80	
	2	SERIES 'B***	14'	80	
LOCAL RESIDENTIAL	2	SERIES 'B'	14'	180	
	2	SERIES 'A'	28'	180	
PASEO, BIKE TRAILS, AND SEPARATED PEDESTRIAN PATHS	-	SERIES 'B'	14'	120	
PEDESTRIAN PATHS ON 4 - 8 LANE STREETS	-	SERIES 'B'	14'	160 - 180***	

NOTES:

1. WATTAGE AND MODEL NUMBER FOR LIGHT EMITTING DIODE (LED) LAMP SHALL BE SPECIFIED ON THE PLANS. EQUIPMENT SHALL CONFORM TO CITY OF ELK GROVE APPROVED EQUIPMENT LIST.

2. ILLUMINATION SHALL CONFORM TO STANDARD DRAWING SL-2.

* BOTH SIDES OF STREET, NO ALTERNATING (2 PER LOCATION). NOT FOR USE ON STREETS LONGER THAN 800 FEET.

** SINGLE SIDE OF STREET, ALTERNATING SPACING.

*** MATCH STREET SPACING. LOCATE HALFWAY BETWEEN STREET LIGHT LOCATIONS.

DATE: 09/22/2007		NOT TO SCALE	
REVISION	BY	APPROVED	DATE

CITY OF ELK GROVE - PUBLIC WORKS

**ZONE 2 POLE SPACING GUIDE
(SERIES 'A'/SERIES 'B'/DUAL ARM)**

APPROVED BY:
Paul Murock 10/24/2018
CITY ENGINEER DATE

DRAWING NUMBER
SL - 36



STREET LIGHT PLACEMENT ON SPECIAL THOROUGHFARE, THOROUGHFARE, & ARTERIAL STREETS (INCLUDES COLLECTORS WITH MEDIAN)

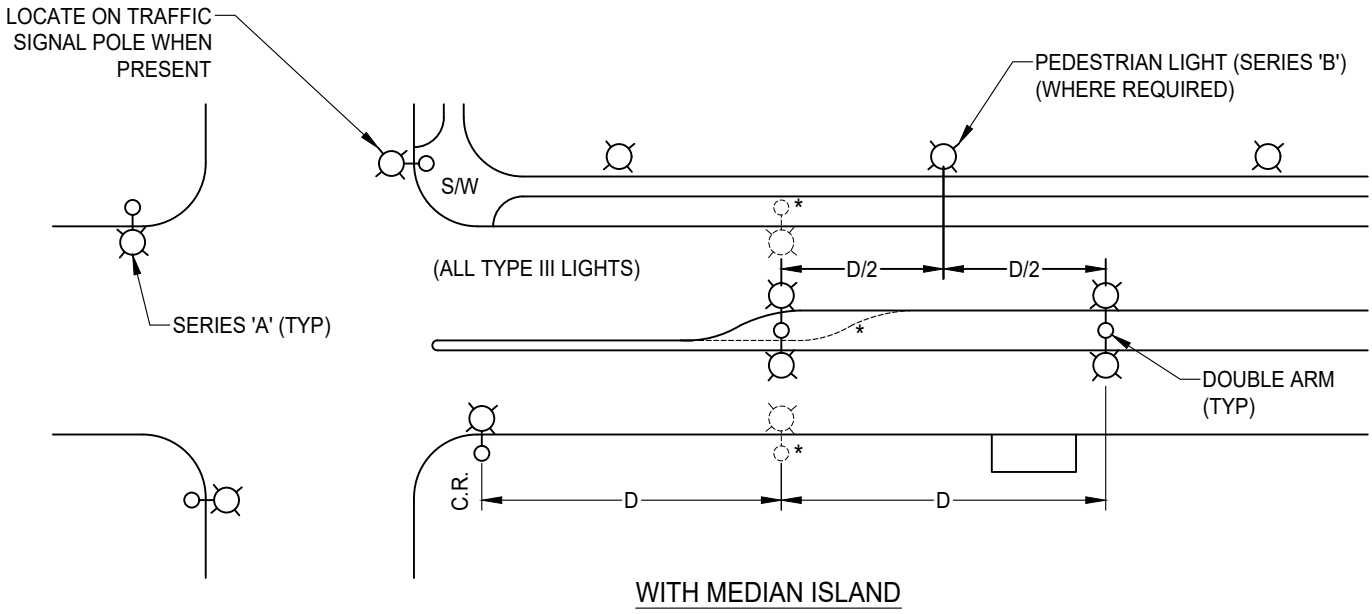

*SEE STANDARD DRAWING SL-36 FOR DISTANCE "D"

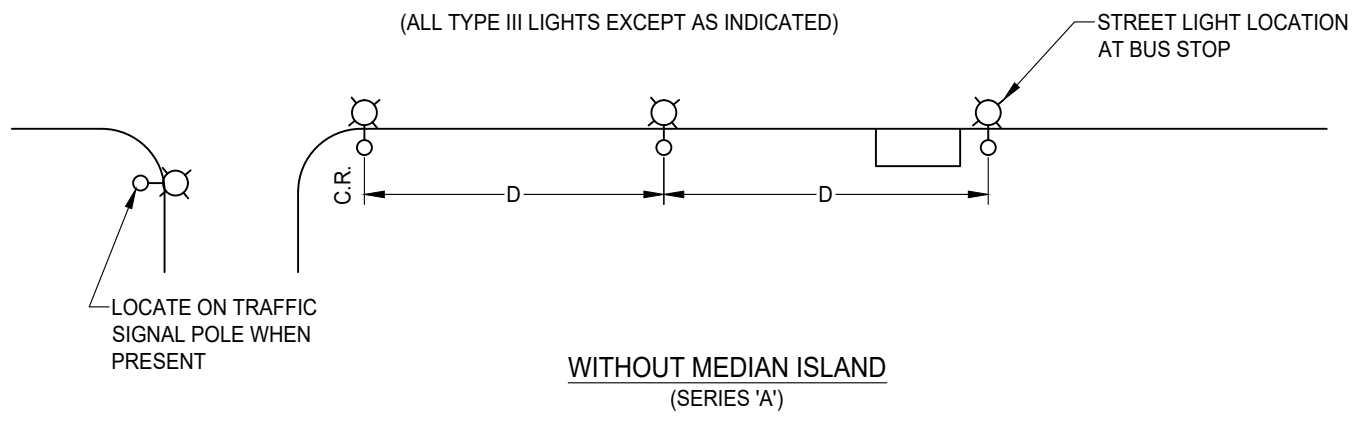
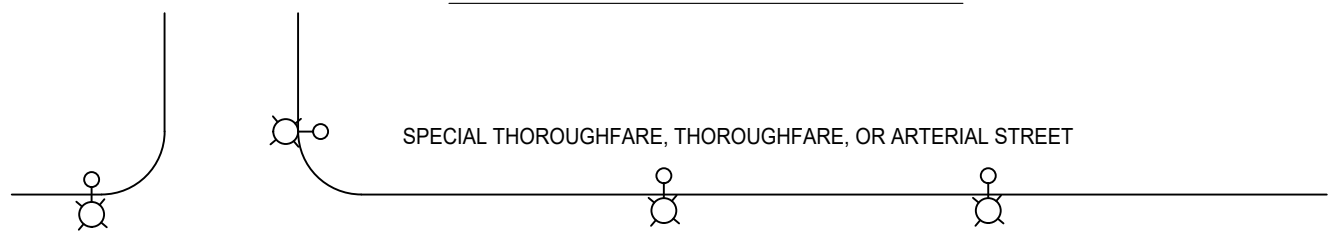

DATE: 09/22/2017		NOT TO SCALE	
REVISION	BY	APPROVED	DATE

CITY OF ELK GROVE - PUBLIC WORKS

**ZONE 2 TYPICAL LOCATIONS ARTERIALS
AND COLLECTORS WITH MEDIANS
(SERIES 'A' / SERIES 'B' / DUAL ARM)**

APPROVED BY:
Paul Murod 10/24/2018
CITY ENGINEER DATE

DRAWING NUMBER
SL - 37



STREET LIGHT PLACEMENT ON MAJOR COLLECTOR, COLLECTOR (NO MEDIAN), & RESIDENTIAL STREETS

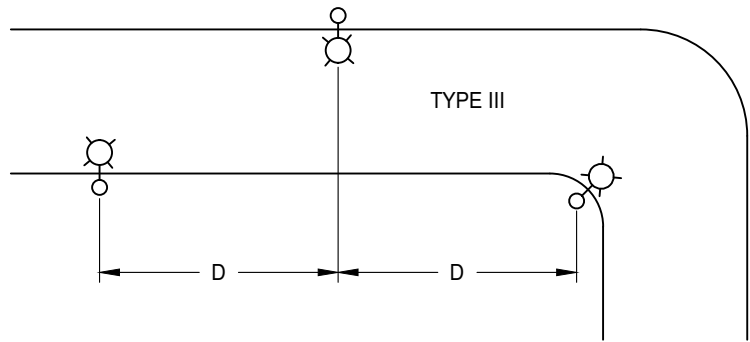
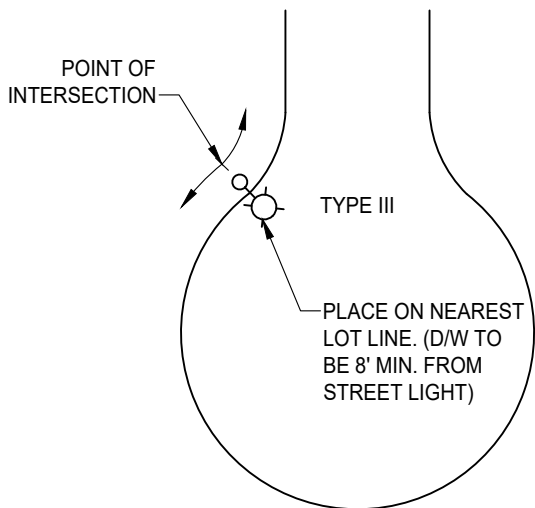
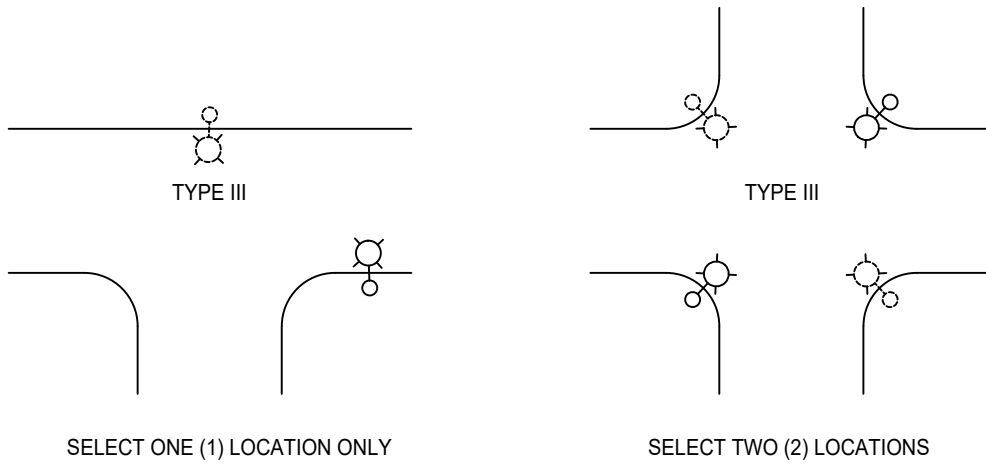

*SEE STANDARD DRAWING SL-36 FOR DISTANCE "D"

DATE: 09/22/2017		NOT TO SCALE	
REVISION	BY	APPROVED	DATE

CITY OF ELK GROVE - PUBLIC WORKS

**ZONE 2 TYPICAL LOCATIONS
COLLECTOR AND RESIDENTIAL STREETS
(SERIES 'A' / SERIES 'B')**

APPROVED BY:
Paul Murook 10/24/2018
CITY ENGINEER DATE

DRAWING NUMBER
SL - 38



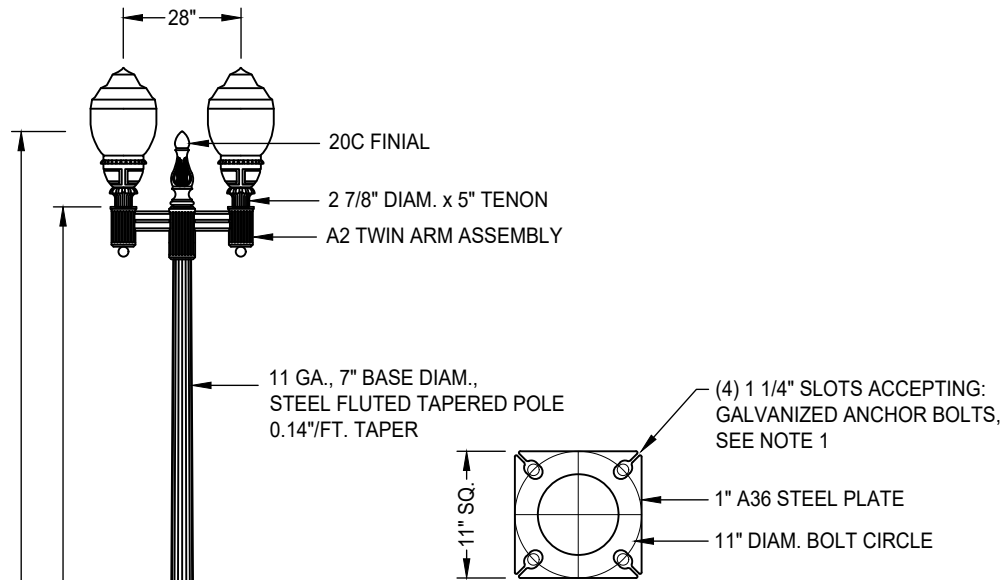

BASE PLATE DETAIL

NOTES:

- ANCHOR BOLT SIZES SHALL BE PURSUANT TO THE POLE MANUFACTURER'S DESIGN REQUIREMENTS, WHICH SHALL BE IN ACCORDANCE WITH AASHTO "STANDARD SPECIFICATIONS FOR STRUCTURAL SUPPORTS FOR HIGHWAY SIGNS, LUMINAIRES, AND TRAFFIC SIGNALS."

- APPLY SILICONE SEALANT AT INSTALLATION
- 12A/7 BASE COLLAR
- 11A/7 UPPER BASE SECTION WITH REMOVABLE ACCESS DOOR

10A LOWER BASE SECTION

APPLICATION:

THOROUGHFARE AND ARTERIAL STREETS

SPECIFICATIONS:

POST DESCRIPTION

THE LAGUNA WEST LIGHTING POST SHALL BE ALL STEEL OR CAST IRON CONSTRUCTION WITH A FLUTED BASE DESIGN. THE STEEL SHAFT SHALL BE FLUTED AND TAPERED WITH A 7" BASE DIAMETER. THE POST SHALL BE SHIPPED WITH FINISH NOTED BELOW.

MATERIALS

THE BASE SHALL BE CAST IRON AND SHAFT SHALL BE STEEL. THE BASE AND SHAFT SHALL BE PRIME PAINTED INSIDE AND OUT WITH A ZINC-RICH RUST INHIBITING, EPOXY BASED PAINT.

POLES INSTALLED ON OR NEAR LAGUNA BLVD (NORTH OF THE ELIOT RANCH ROAD ALIGNMENT) SHALL BE PAINTED OUTSIDE WITH URETHANE GLOSS ENAMEL OF FEDERAL COLOR STANDARD 595B, COLOR #14516 "AQUA MARINE". POLES INSTALLED ON OR NEAR ELK GROVE BLVD (SOUTH OF THE ELIOT RANCH ROAD ALIGNMENT) SHALL BE PAINTED OUTSIDE WITH URETHANE GLOSS ENAMEL OF FEDERAL COLOR STANDARD 595B, COLOR #17083 "GLOSS BLACK". ONE PINT OF TOUCH-UP PAINT SHALL BE SHIPPED WITH EACH POLE ORDER.

ALL POLES SHALL BE FINISHED WITH A CLEAR COAT OF URETHANE GLOSS FINISH. ANCHOR BOLTS AND NUTS SHALL BE HOT DIPPED GALVANIZED STEEL.

CONSTRUCTION

THE POLE SHAFT SHALL BE WELDED TO THE ANCHOR PLATE AND PAINTED AFTER WELDING. WELDS SHALL CONFORM TO THE MOST RECENT EDITION OF AWS D1.1. THE BASE SHALL BE FABRICATED OF ONE OR TWO PIECES AND INSTALLED AFTER THE POLE SHAFT IS BOLTED TO THE FOUNDATION. THE FINISH OF THE POLE SHAFT SHALL BE PROTECTED FROM DAMAGE WHEN THE BASE IS INSTALLED. POLE AND BASE SHALL BE SHIPPED AS TWO PIECES.

DIMENSIONS

THE POST SHALL BE 19' 6" IN HEIGHT WITH A 20" DIAMETER BASE. THE SHAFT SHALL BE TAPERED 0.14" PER FOOT WITH A 7" BASE DIAMETER. AT THE TOP OF THE POST, TWO INTEGRAL 2 7/8" X5" TENONS SHALL BE PROVIDED FOR LUMINAIRE MOUNTING.

INSTALLATION

THE POST SHALL BE PROVIDED WITH FOUR, HOT DIP GALVANIZED L-TYPE ANCHOR BOLTS TO BE INSTALLED AS SHOWN IN THE BASE PLATE DETAIL. AN ACCESS DOOR SHALL BE PROVIDED IN THE BASE FOR ANCHORAGE AND WIRING ACCESS. A GROUNDING SCREW (5/8") SHALL BE PROVIDED INSIDE THE BASE OPPOSITE THE DOOR.

PRODUCT

VISCO V1-A7-A2-F/19' 6", ELK GROVE

DATE 09/22/2007		NOT TO SCALE	
REVISION	BY	APPROVED	DATE
01	STN	JRW	02/16/2021

CITY OF ELK GROVE - PUBLIC WORKS

**LAGUNA WEST ELECTROLIER
(DUAL ARM)**

APPROVED BY:
Robert M. Muddoch
CITY ENGINEER 02/26/2021
DATE



DRAWING NUMBER
SL - 40

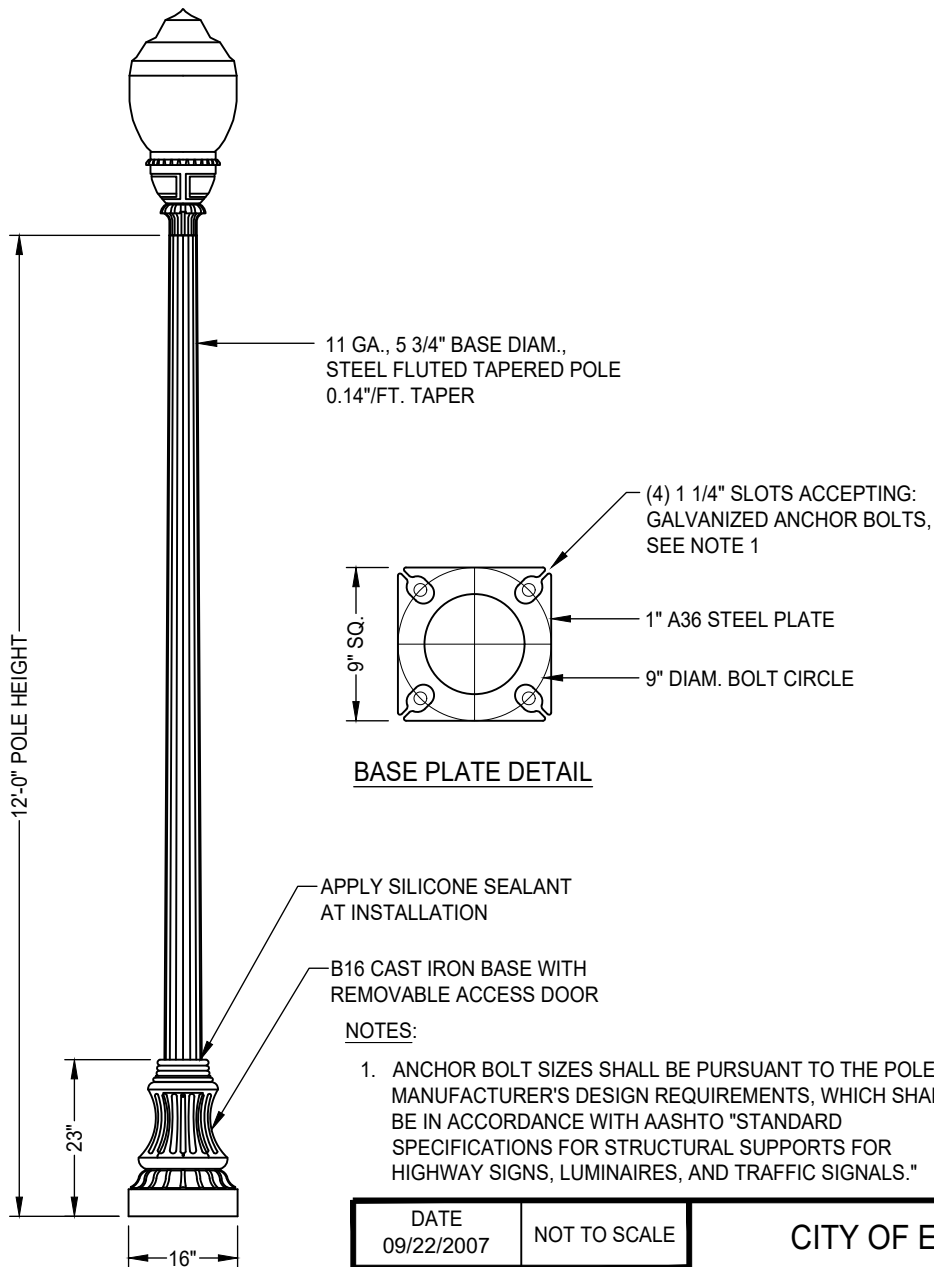

11 GA., 5 3/4" BASE DIAM.,
STEEL FLUTED TAPERED POLE
0.14"/FT. TAPER

(4) 1 1/4" SLOTS ACCEPTING:
GALVANIZED ANCHOR BOLTS,
SEE NOTE 1

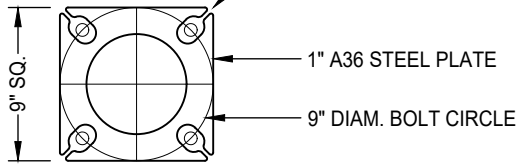

BASE PLATE DETAIL

APPLY SILICONE SEALANT
AT INSTALLATION

B16 CAST IRON BASE WITH
REMOVABLE ACCESS DOOR

NOTES:

1. ANCHOR BOLT SIZES SHALL BE PURSUANT TO THE POLE MANUFACTURER'S DESIGN REQUIREMENTS, WHICH SHALL BE IN ACCORDANCE WITH AASHTO "STANDARD SPECIFICATIONS FOR STRUCTURAL SUPPORTS FOR HIGHWAY SIGNS, LUMINAIRES, AND TRAFFIC SIGNALS."

APPLICATION:

RESIDENTIAL STREETS AND PEDESTRIAN TRAILS

SPECIFICATIONS:

POST DESCRIPTION

THE LAGUNA WEST LIGHTING POST SHALL BE ALL STEEL OR CAST IRON CONSTRUCTION WITH A FLUTED BASE DESIGN. THE SHAFT SHALL BE FLUTED AND TAPERED WITH A 5 3/4" BASE DIAMETER. THE POST SHALL BE SHIPPED WITH FINISH NOTED BELOW.

MATERIALS

THE BASE SHALL BE CAST IRON AND SHAFT SHALL BE STEEL. THE BASE AND SHAFT SHALL BE PRIME PAINTED INSIDE AND OUT WITH RUST INHIBITING, EPOXY BASED PAINT.

POLES INSTALLED ON OR NEAR LAGUNA BLVD (NORTH OF THE ELLIOT RANCH ROAD ALIGNMENT) SHALL BE PAINTED OUTSIDE WITH URETHANE GLOSS ENAMEL OF FEDERAL COLOR STANDARD 595B, COLOR #14516 "AQUA MARINE". POLES INSTALLED ON OR NEAR ELK GROVE BLVD (SOUTH OF THE ELLIOT RANCH ROAD ALIGNMENT) SHALL BE PAINTED OUTSIDE WITH URETHANE GLOSS ENAMEL OF FEDERAL COLOR STANDARD 595B, COLOR #17083 "GLOSS BLACK". ONE PINT OF TOUCH-UP PAINT SHALL BE SHIPPED WITH EACH POLE ORDER.

ALL POLES SHALL BE FINISHED WITH A CLEAR COAT OF URETHANE GLOSS FINISH. ANCHOR BOLTS AND NUTS SHALL BE HOT DIPPED GALVANIZED STEEL.

CONSTRUCTION

THE POLE SHAFT SHALL BE WELDED TO THE ANCHOR PLATE AND PAINTED AFTER WELDING. WELDS SHALL CONFORM TO THE MOST RECENT EDITION OF AWS D1.1. THE BASE SHALL BE FABRICATED OF ONE OR TWO PIECES AND INSTALLED AFTER THE POLE SHAFT IS BOLTED TO THE FOUNDATION. THE FINISH OF THE POLE SHAFT SHALL BE PROTECTED FROM DAMAGE WHEN THE BASE IS INSTALLED. POLE AND BASE SHALL BE SHIPPED AS TWO PIECES.

DIMENSIONS

THE POST SHALL BE 12' 0" IN HEIGHT WITH A 16" DIAMETER BASE. THE SHAFT SHALL BE TAPERED 0.14" PER FOOT WITH A 5 3/4" BASE DIAMETER. AT THE TOP OF THE POST, AN INTEGRAL 2 7/8" X3" TENON SHALL BE PROVIDED FOR LUMINAIRE MOUNTING.

INSTALLATION

THE POST SHALL BE PROVIDED WITH FOUR, HOT DIP GALVANIZED L-TYPE ANCHOR BOLTS TO BE INSTALLED AS SHOWN IN THE BASE PLATE DETAIL. AN ACCESS DOOR SHALL BE PROVIDED IN THE BASE FOR ANCHORAGE AND WIRING ACCESS. A GROUNDING SCREW (5/8") SHALL BE PROVIDED INSIDE THE BASE OPPOSITE THE DOOR.

PRODUCT

VISCO V1-B16-1-F/12', ELK GROVE

DATE 09/22/2007		NOT TO SCALE	
REVISION	BY	APPROVED	DATE
01	STN	JRW	02/16/2021

CITY OF ELK GROVE - PUBLIC WORKS

**LAGUNA WEST ELECTROLIER
(SERIES 'B')**

APPROVED BY:

Paul M. Muelich

02/26/2021

CITY ENGINEER

DATE



DRAWING NUMBER

SL - 42

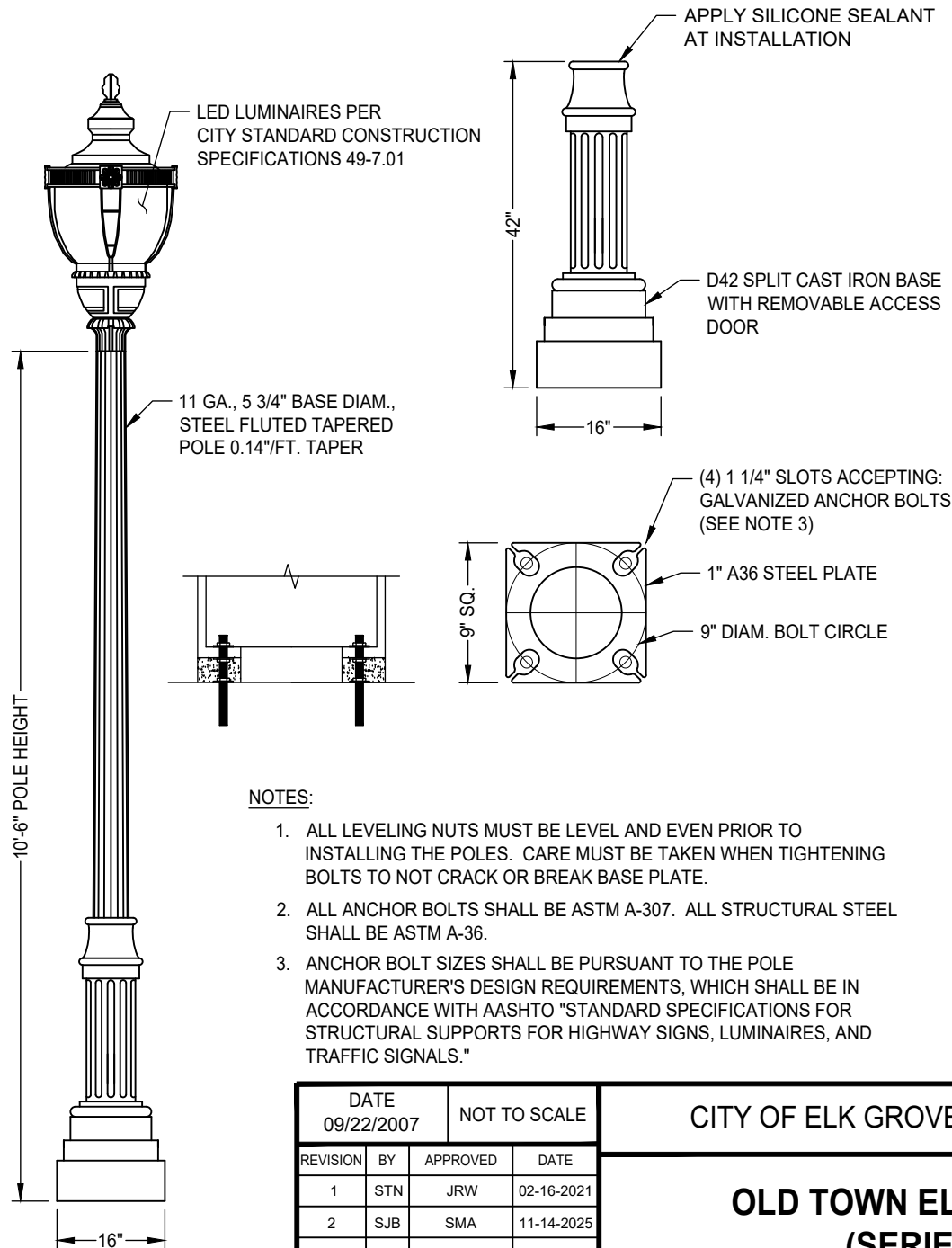

NOTES:

1. ALL LEVELING NUTS MUST BE LEVEL AND EVEN PRIOR TO INSTALLING THE POLES. CARE MUST BE TAKEN WHEN TIGHTENING BOLTS TO NOT CRACK OR BREAK BASE PLATE.
2. ALL ANCHOR BOLTS SHALL BE ASTM A-307. ALL STRUCTURAL STEEL SHALL BE ASTM A-36.
3. ANCHOR BOLT SIZES SHALL BE PURSUANT TO THE POLE MANUFACTURER'S DESIGN REQUIREMENTS, WHICH SHALL BE IN ACCORDANCE WITH AASHTO "STANDARD SPECIFICATIONS FOR STRUCTURAL SUPPORTS FOR HIGHWAY SIGNS, LUMINAIRES, AND TRAFFIC SIGNALS."

APPLICATION:

BUSINESS DISTRICT OLD TOWN

SPECIFICATIONS:

POST DESCRIPTION

THE OLD TOWN LIGHTING POST SHALL BE ALL STEEL CONSTRUCTION WITH A FLUTED BASE DESIGN. THE SHAFT SHALL BE FLUTED AND TAPERED WITH A 5/8" BASE DIAMETER. THE POST SHALL BE SHIPPED WITH FINISH NOTED BELOW.

MATERIALS

THE BASE AND POLE SHALL BE CAST STEEL. THE BASE AND POLE SHALL BE PRIME PAINTED INSIDE AND OUT WITH RUST INHIBITING, EPOXY BASED PAINT, PAINTED OUTSIDE WITH URETHANE GLOSS ENAMEL OF FEDERAL COLOR STANDARD 595B, COLOR #17083 "GLOSS BLACK", AND FINISHED WITH A CLEAR COAT OF URETHANE GLOSS FINISH. ANCHOR BOLTS AND NUTS SHALL BE HOT DIPPED GALVANIZED STEEL.

CONSTRUCTION

THE SHAFT AND BASE SHALL BE CAST IN ONE PIECE OR SHALL BE DOUBLE WELDED (TOP AND BOTTOM OF BASE). WELDS SHALL BE GROUND SMOOTH. WELDS SHALL CONFORM TO AWS D1.1. POLE AND BASE SHALL BE SHIPPED AS ONE PIECE.

DIMENSIONS

THE POST SHALL BE 10' 6" IN HEIGHT WITH AN 11.5" DIAMETER BASE. THE SHAFT SHALL BE TAPERED WITH A 5/8" BASE DIAMETER. AT THE TOP OF THE POST, AN INTEGRAL 2 7/8" X3" TENON SHALL BE PROVIDED FOR LUMINAIRE MOUNTING.

INSTALLATION

THE POST SHALL BE PROVIDED WITH FOUR, HOT DIP GALVANIZED L-TYPE ANCHOR BOLTS TO BE INSTALLED AS SHOWN IN THE BASE DETAIL. AN ACCESS DOOR SHALL BE PROVIDED IN THE BASE FOR ANCHORAGE AND WIRING ACCESS. A GROUNDING SCREW (5/8") SHALL BE PROVIDED INSIDE THE BASE OPPOSITE THE DOOR.

PRODUCT

VISCO V1-D42-F, ELK GROVE 3A

DATE 09/22/2007		NOT TO SCALE	
REVISION	BY	APPROVED	DATE
1	STN	JRW	02-16-2021
2	SJB	SMA	11-14-2025

CITY OF ELK GROVE - PUBLIC WORKS

**OLD TOWN ELECTROLIER
(SERIES 'B')**

APPROVED BY:

[Signature] 11-14-2025

CITY ENGINEER

DATE



DRAWING NUMBER

SL - 46

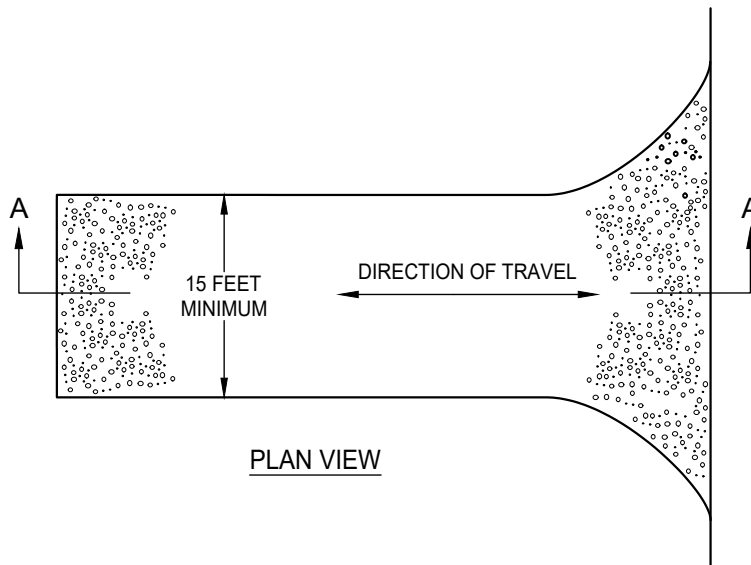
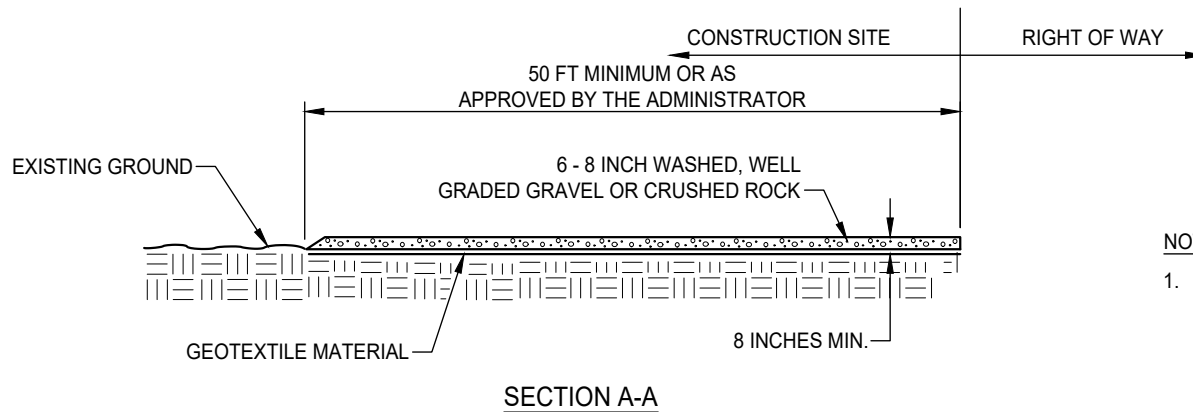

NOTES:

1. STABILIZED CONSTRUCTION SITE ACCESS SHALL BE CONSTRUCTED OF 6 - 8 INCH WASHED, WELL GRADED GRAVEL OR CRUSHED ROCK. MATERIAL SHALL BE PLACED TO A MINIMUM THICKNESS OF 8 INCHES. ROUND ROCK (RIVER ROCK) NOT ALLOWED.
2. LENGTH OF ENTRANCE SHALL BE A MINIMUM OF 50 FEET. WIDTH SHALL BE A MINIMUM OF 15 FEET OR GREATER IF NECESSARY TO COVER ALL VEHICULAR INGRESS AND EGRESS. PROVIDE AMPLE TURNING RADII.
3. THE ENTRANCE SHALL BE KEPT IN GOOD CONDITION BY OCCASIONAL TOP DRESSING WITH MATERIAL AS SPECIFIED IN NOTE 1.
4. ACCESS SHALL BE INSPECTED WEEKLY DURING PERIODS OF HEAVY USAGE, MONTHLY DURING NORMAL USAGE, AND AFTER EACH RAINFALL, WITH MAINTENANCE PROVIDED AS NECESSARY. PERIODIC TOP DRESSING SHALL BE DONE AS NEEDED.

DATE: 09/22/2007		NOT TO SCALE	
REVISION	BY	APPROVED	DATE

CITY OF ELK GROVE - PUBLIC WORKS

STABILIZED CONSTRUCTION SITE ACCESS

APPROVED BY:
Paul Murock 10/24/2018
CITY ENGINEER DATE

DRAWING NUMBER
SQ - 1



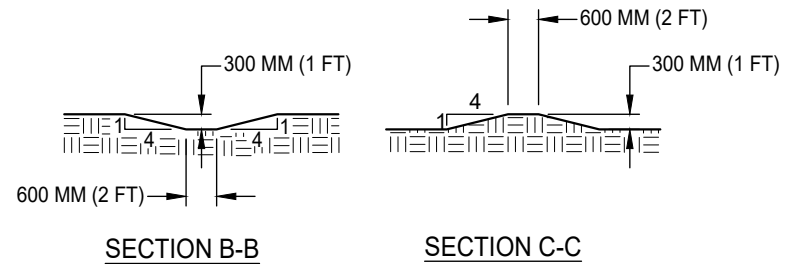
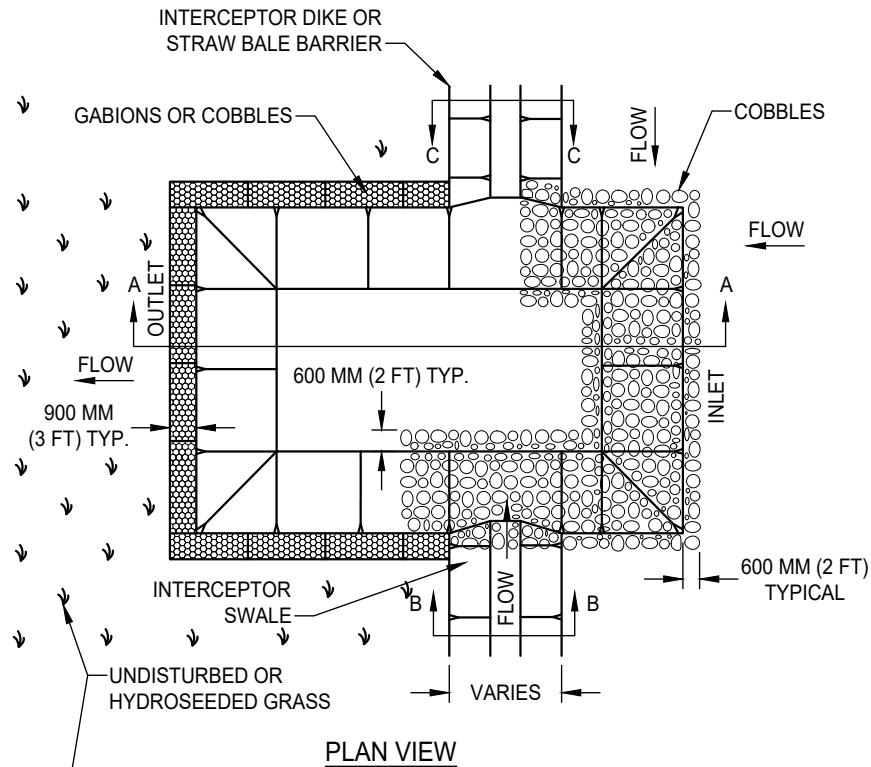

NOTES:

1. DIMENSIONS OF SEDIMENT TRAPS, DIKES, AND SWALES SHALL BE APPROVED BY THE ADMINISTRATOR.
2. INTERCEPTION DIKES AND SWALES SHALL BE CONSTRUCTED TO DRAIN SURFACE RUNOFF INTO SEDIMENT TRAPS.
3. TRAPS SHALL BE EXCAVATED WITH APPROPRIATE EQUIPMENT, TAKING CARE NOT TO DISTURB VEGETATION OR SOIL AT OUTLET CREST. SIDE SLOPES SHALL BE 1:3 OR FLATTER. MAXIMUM TRAP DEPTH SHALL BE 1.1 METERS (3.5 FEET).
4. COBBLES CONFORMING TO CITY OF ELK GROVE SPECIFICATIONS SHALL BE PLACED ON THE TOPS, SLOPES, AND BOTTOMS OF THE INLET SIDES. COBBLES SHALL EXTEND A MINIMUM OF 600 MM (2 FEET) BEYOND THE TOP AND TOE OF SLOPES.
5. PERIMETER OF SEDIMENT TRAPS SHALL BE STABILIZED WITH GABIONS OR COBBLES AND HYDROSEEDED 3 METERS (10 FEET) BEYOND EDGE OF EXCAVATION IF EXISTING VEGETATION IS THIN, DISTURBED OR NONEXISTENT.
6. THE CONTRACTOR SHALL INSPECT SEDIMENT TRAPS WEEKLY AND AFTER EACH RAINFALL AND CLEAN AND REPAIR AS NECESSARY. SEDIMENT SHALL BE REMOVED FROM THE BOTTOM OF THE TRAP WHEN 300 MM (1 FOOT) DEEP OR LESS.

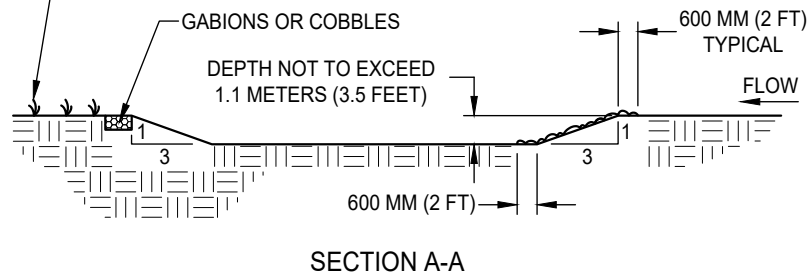

DATE: 09/22/2007		NOT TO SCALE	
REVISION	BY	APPROVED	DATE

CITY OF ELK GROVE - PUBLIC WORKS

**SEDIMENT TRAP
STABILIZED OUTLET**

APPROVED BY:

Paul Murock

10/24/2018

CITY ENGINEER

DATE



DRAWING NUMBER

SQ - 3

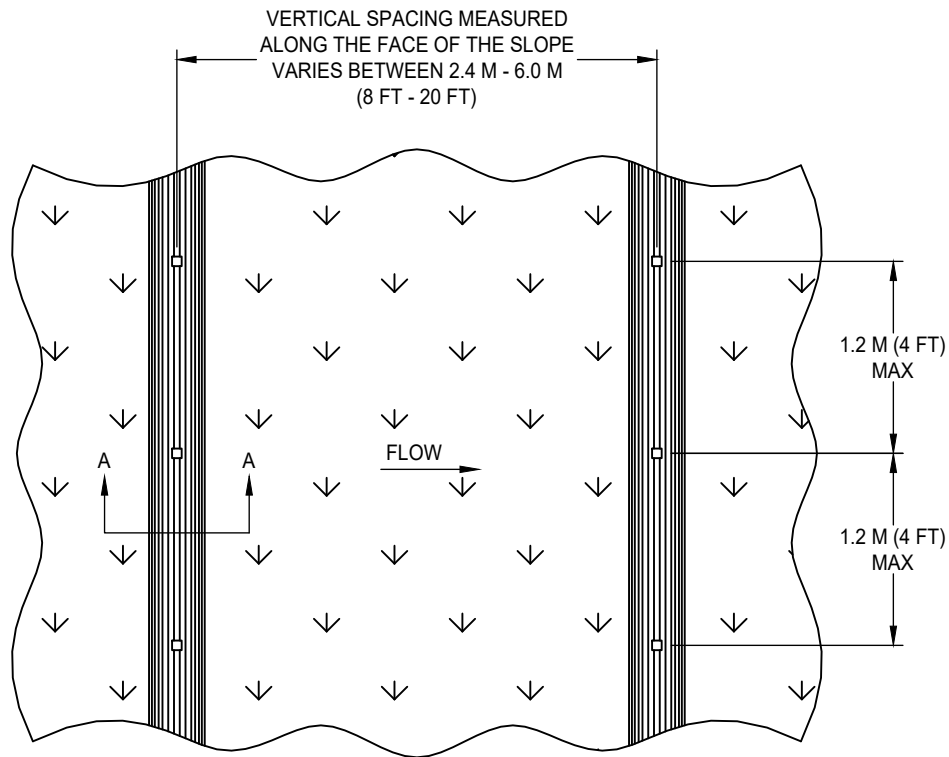

TYPICAL FIBER ROLL INSTALLATION

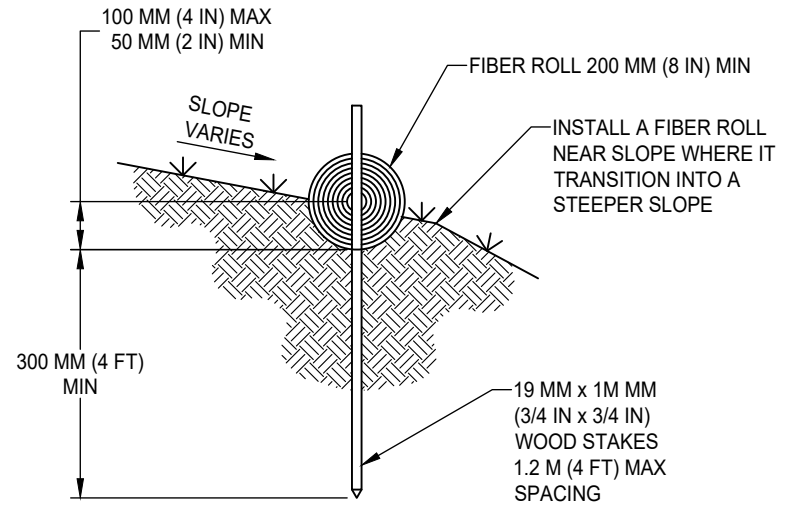

SECTION A-A

NOTES:

1. INSTALL FIBER ROLL IN A ROW ALONG A LEVEL CONTOUR.
2. AT ENDS OF A ROW TURN THE LAST TWO FET UP SLOPE SLIGHTLY.
3. FIBER ROLLS SHALL BE BUTTED TIGHTLY AT THE JOINTS.
4. DO NOT OVERLAP JOINTS.

DATE: 09/22/2007		NOT TO SCALE	
REVISION	BY	APPROVED	DATE

CITY OF ELK GROVE - PUBLIC WORKS

FIBER ROLLS

APPROVED BY:

Paul M. Muebeck

CITY ENGINEER

10/24/2018

DATE



DRAWING NUMBER

SQ - 4

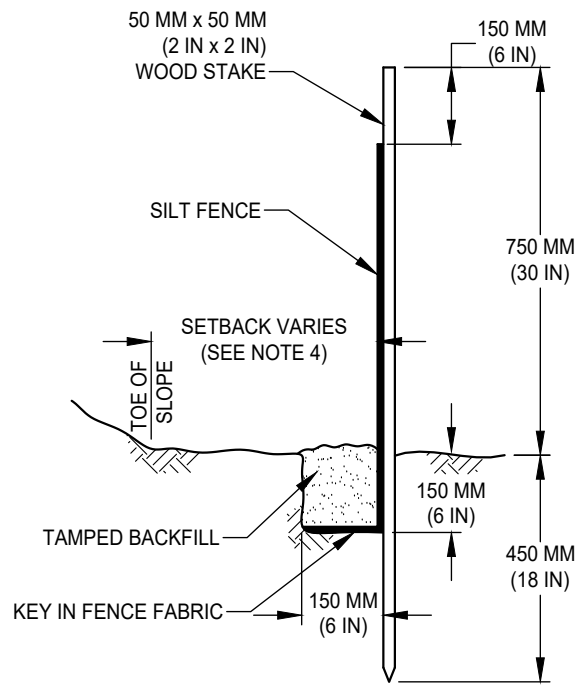

FENCE SECTION DETAIL

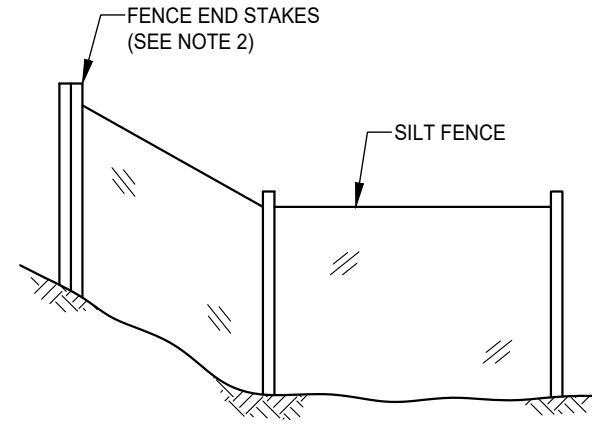

FENCE END DETAIL

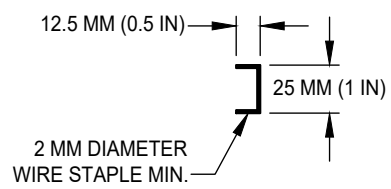

STAPLE DETAIL

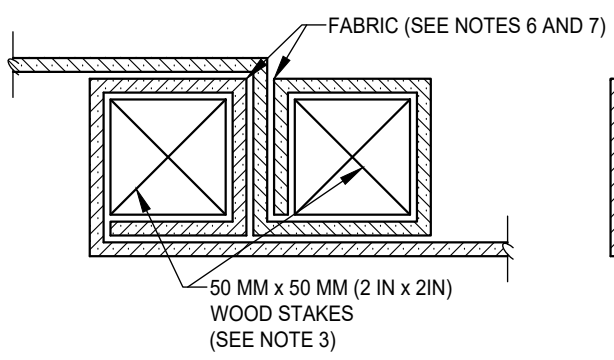

JOINT DETAIL

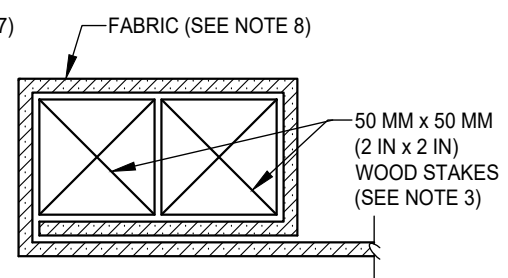

END STAKE DETAIL

NOTES:

1. CONSTRUCT THE LENGTH OF EACH REACH SO THAT THE CHANGE IN BASE ELEVATION ALONG THE REACH DOES NOT EXCEED 1/3 THE HEIGHT OF THE LINEAR BARRIER. IN NO CASE SHALL THE REACH LENGTH EXCEED 150 MM (6 IN)
2. THE LAST 2.4 M (8 FT) OF FENCE SHALL BE TURNED UP SLOPE.
3. STAKE DIMENSIONS ARE NOMINAL.
4. DIMENSIONS MAY VARY TO FIT FIELD CONDITION.
5. STAKES SHALL BE SPACED AT 2.4 M (8 FT) MAXIMUM AND SHALL BE POSITIONED ON THE DOWNSTREAM SIDE OF THE FENCE.
6. OVERLAP STAKES, AND FOLD FENCE FABRIC TO ROUND EACH STAKE ONE FULL TURN.
7. STAKES SHALL BE DRIVEN TIGHTLY TOGETHER TO PREVENT POTENTIAL FLOW THROUGH OF SEDIMENT AT THE JOINT.
8. FOR END STAKE CONDITION FOLD FENCE FABRIC AROUND (2) STAKES (1) FULL TURN AND SECURE WITH (4) STAPLES.
9. MINIMUM (4) STAPLES PER STAKE.
10. CROSS BARRIERS SHALL BE MINIMUM OF 1/3 AND MAXIMUM OF 1/2 THE HEIGHT OF THE LINEAR BARRIER.

DATE: 09/22/2007		NOT TO SCALE	
REVISION	BY	APPROVED	DATE

CITY OF ELK GROVE - PUBLIC WORKS

SILT FENCE

APPROVED BY:
Paul Murock
CITY ENGINEER

10/24/2018
DATE

DRAWING NUMBER
SQ - 5



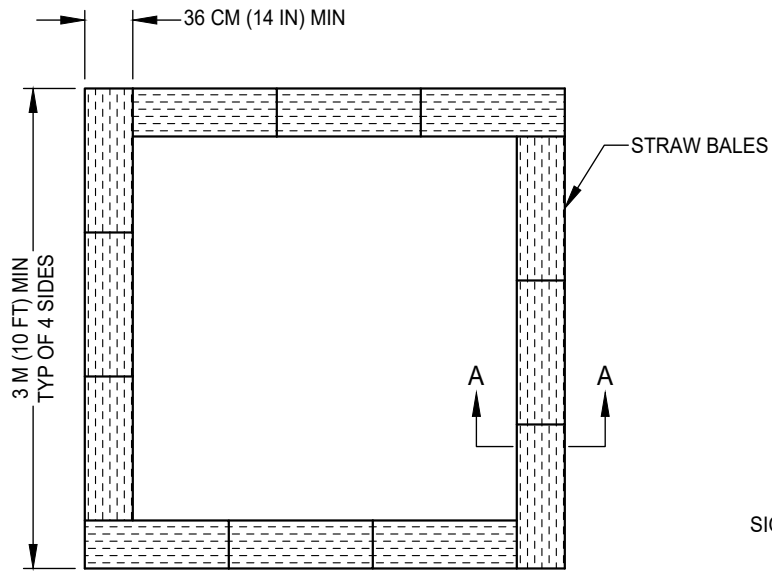

BALE CONFIGURATION

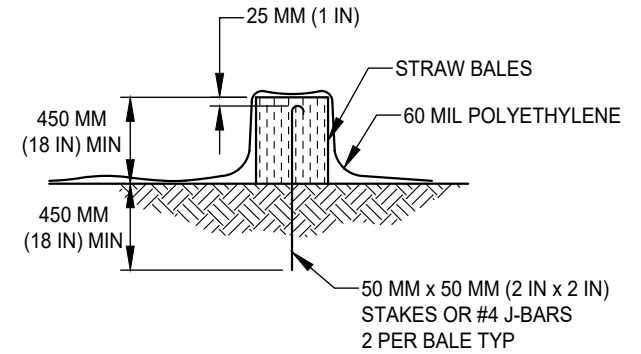

SECTION A-A

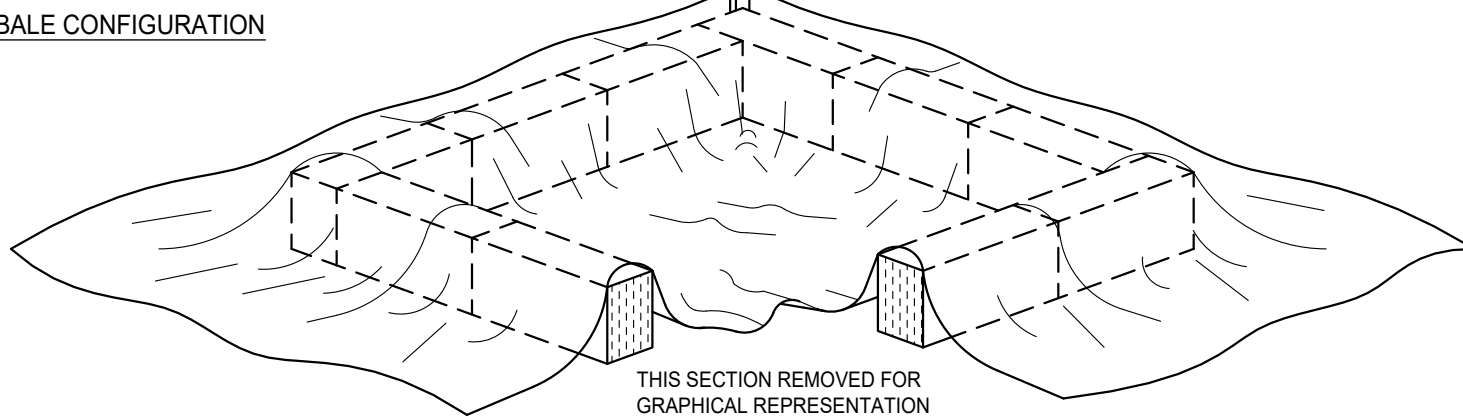
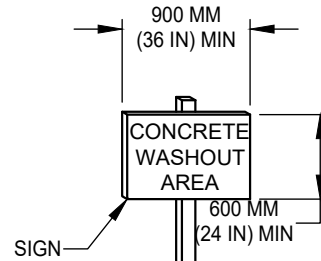

THIS SECTION REMOVED FOR GRAPHICAL REPRESENTATION ONLY. STRAW BALE PERIMETER SHALL BE CONTINUOUS.

NOTES:

1. FACE SIGN TOWARD NEAREST STREET OR ACCESS POINT.
2. CONCRETE WASHOUT SHALL BE LOCATED BEHIND THE CURB AND 15 M (50 FT) MINIMUM FROM DRAINAGE INLETS OR WATERCOURSES.

DATE: 09/22/2007		NOT TO SCALE	
REVISION	BY	APPROVED	DATE

CITY OF ELK GROVE - PUBLIC WORKS

APPROVED BY:

Paul Murock

10/24/2018

CITY ENGINEER

DATE

CONCRETE WASHOUT



DRAWING NUMBER

SQ - 6

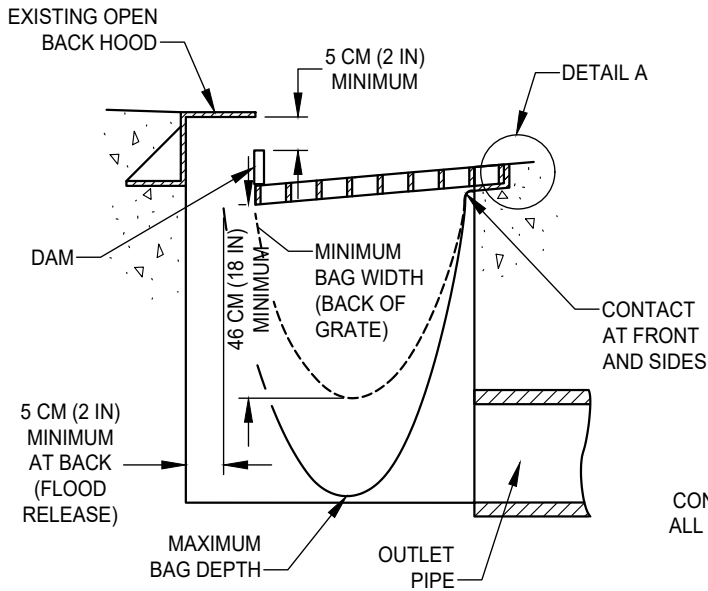

**PLACEMENT AT TYPE B AND E
DROP INLETS**

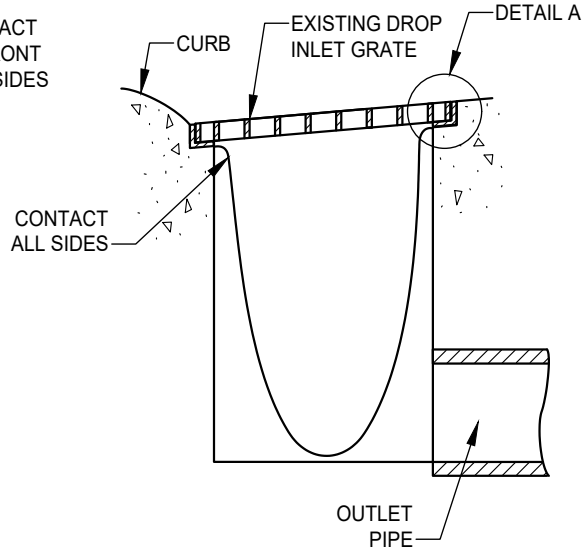

**PLACEMENT AT TYPE A, C, D, & F DROP INLETS
AND PARKING LOTS**

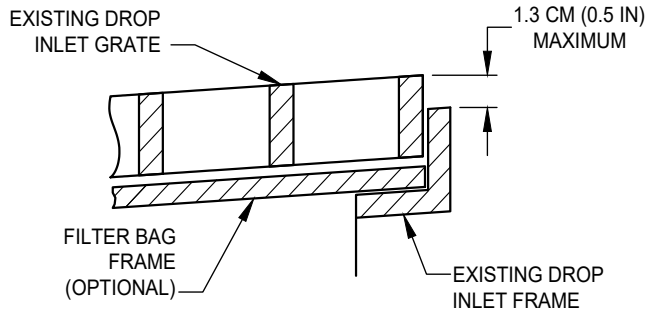

DETAIL A

NOTES:

1. THE MAXIMUM DRAINAGE AREA PER FILTER SHALL BE NO MORE THAN 0.8 HECTARES (2 ACRES).
2. THE FILTER BAG SHALL BE MANUFACTURED FROM UV RESISTANT POLYPROPYLENE, NYLON, POLYESTER, OR ETHYLENE FABRIC WITH A MINIMUM TENSILE STRENGTH OF 50 LBS PER LINEAL FOOT, AN EQUIVALENT OPENING SIZE NOT GREATER THAN 20 SIEVE AND WITH GALLONS/MINUTE/SQ FT.
3. THE FILTER BAG MAY BE SUSPENDED FROM OR HELD IN PLACE ON EXISTING INLET GRATE (OR OTHER APPROVED METHOD), PROVIDING NO MODIFICATION OR DAMAGE SHALL BE DONE TO THE INLET GRATE OR FRAME. THE INLET GRATE SHALL NOT BE CAUSED TO REST MORE THAN 13 MM (0.5 IN) ABOVE THE INLET FRAME (SEE DETAIL A).
4. THE FILTER BAG MAY EXTEND TO THE BOTTOM OF THE INLET BOX PROVIDED THE OUTLET PIPE IS UNOBSTRUCTED.
5. FLOWS SHALL NOT BE ALLOWED TO BYPASS THE BAG. THE BAG OR ITS FRAME SHALL CATCH FLOWS AT ALL SIDES OF THE INLET, EXCEPT AS SHOWN FOR FLOOD RELEASE.
6. INLET FILTER BAGS SHALL BE INSPECTED WEEKLY AND AFTER EACH RAINFALL DURING THE WET SEASON AND MONTHLY DURING THE DRY SEASON. SEDIMENT AND DEBRIS SHALL BE REMOVED BEFORE ACCUMULATIONS HAVE REACHED ONE THIRD THE DEPTH OF THE BAG. BAGS SHALL BE REPAIRED OR REPLACED AS SOON AS DAMAGE OCCURS.

DATE: 09/22/2007		NOT TO SCALE	
REVISION	BY	APPROVED	DATE

CITY OF ELK GROVE - PUBLIC WORKS

STORM DRAIN INLET FILTER BAG

APPROVED BY:
Paul M. Muebeck
CITY ENGINEER

10/24/2018
DATE

DRAWING NUMBER
SQ - 8



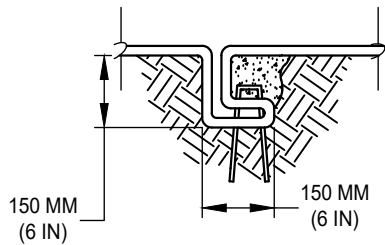

CHECK SLOT

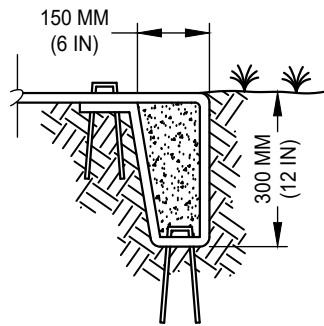

INITIAL CHANNEL ANCHOR TRENCH

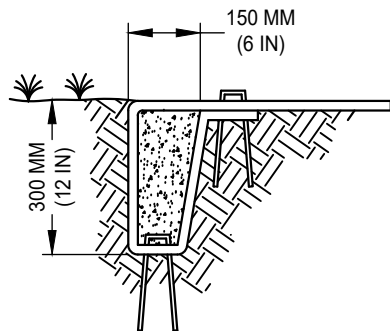

TERMINAL SLOPE AND CHANNEL ANCHOR TRENCH

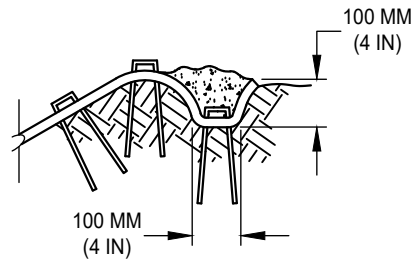
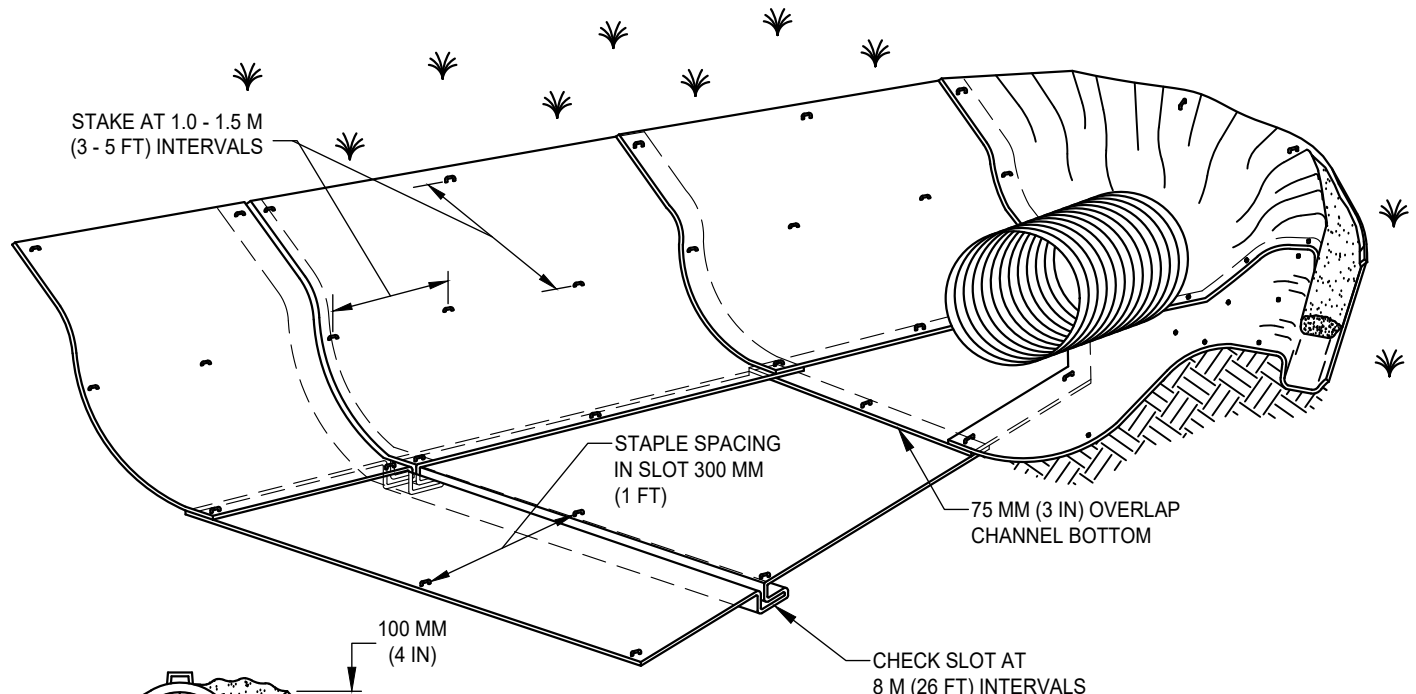

LONGITUDINAL ANCHOR TRENCH

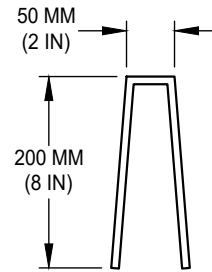

WIRE STAPLES

TYPICAL CHANNEL SOIL STABILIZATION

NOTE:

1. CONSTRUCTION OF CHECK SLOTS, STAKING, STAPLING LAYOUT, AND MAT INSTALLATION ALL TO BE DONE PER MANUFACTURER'S SPECIFICATIONS.

DATE: 09/22/2007		NOT TO SCALE	
REVISION	BY	APPROVED	DATE

CITY OF ELK GROVE - PUBLIC WORKS

EROSION CONTROL BLANKETS / MATS CHANNEL INSTALLATION

APPROVED BY:
Paul Murock
CITY ENGINEER

10/24/2018
DATE

DRAWING NUMBER
SQ - 9A



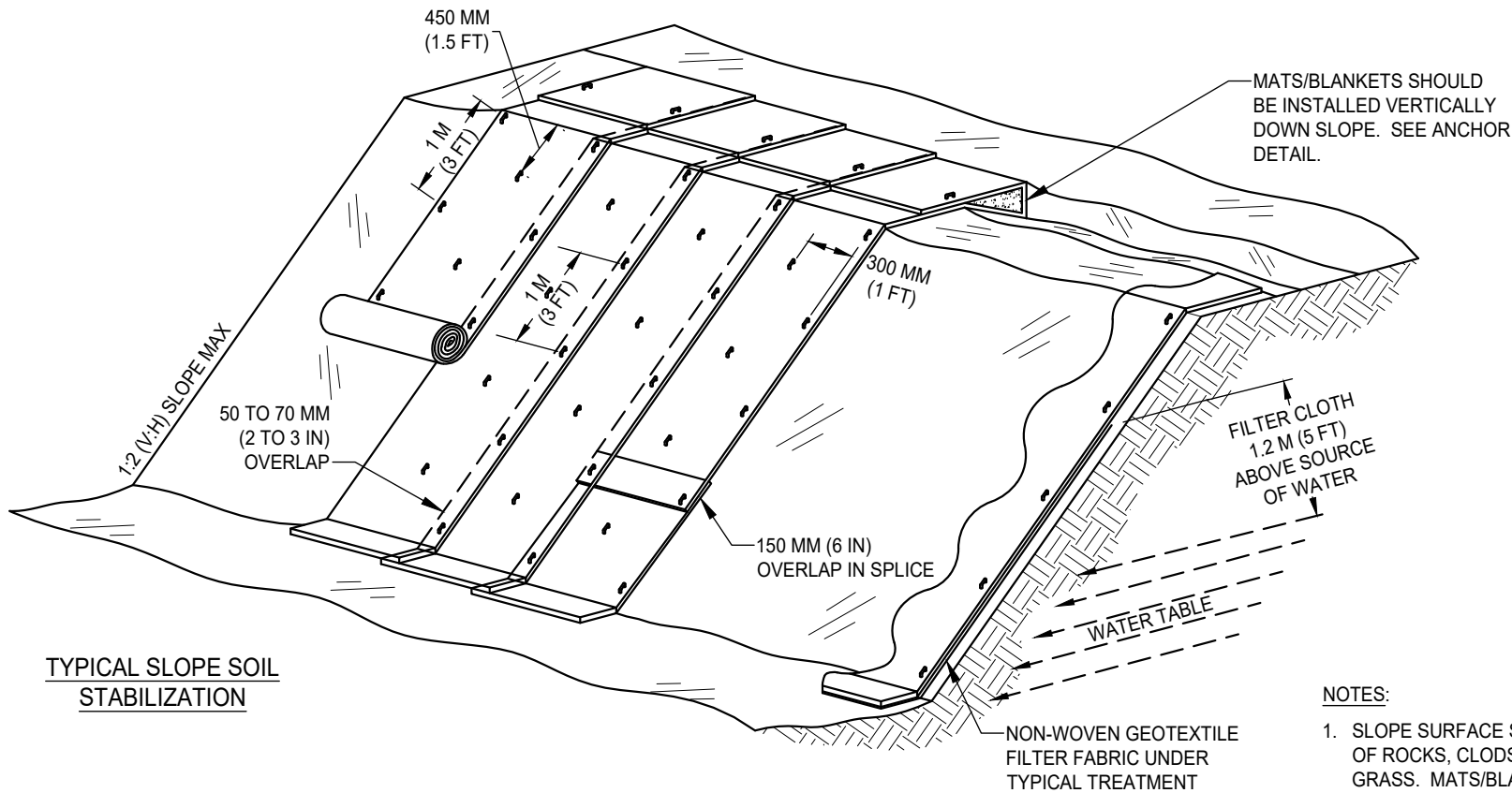

TYPICAL SLOPE SOIL STABILIZATION

WET SLOPE LINING

NOTES:

1. SLOPE SURFACE SHALL BE FREE OF ROCKS, CLODS, STICKS AND GRASS. MATS/BLANKETS SHALL HAVE GOOD SOIL CONTACT.
2. LAY BLANKETS LOOSELY AND STAKE OR STAPLE TO MAINTAIN DIRECT CONTACT WITH THE SOIL. DO NOT STRETCH.
3. INSTALL PER MANUFACTURER'S RECOMMENDATIONS.

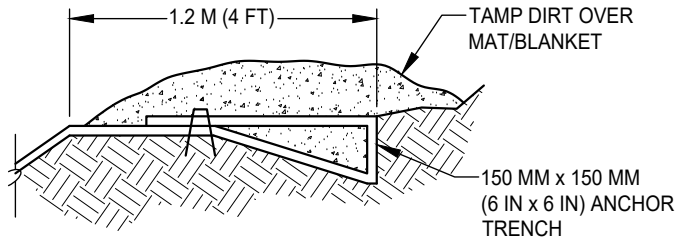

ANCHOR DETAIL

DATE: 09/22/2007		NOT TO SCALE	
REVISION	BY	APPROVED	DATE

CITY OF ELK GROVE - PUBLIC WORKS

EROSION CONTROL BLANKETS/MATS SLOPE INSTALLATION

APPROVED BY:

Paul Murock

10/24/2018

CITY ENGINEER

DATE



DRAWING NUMBER

SQ - 9B

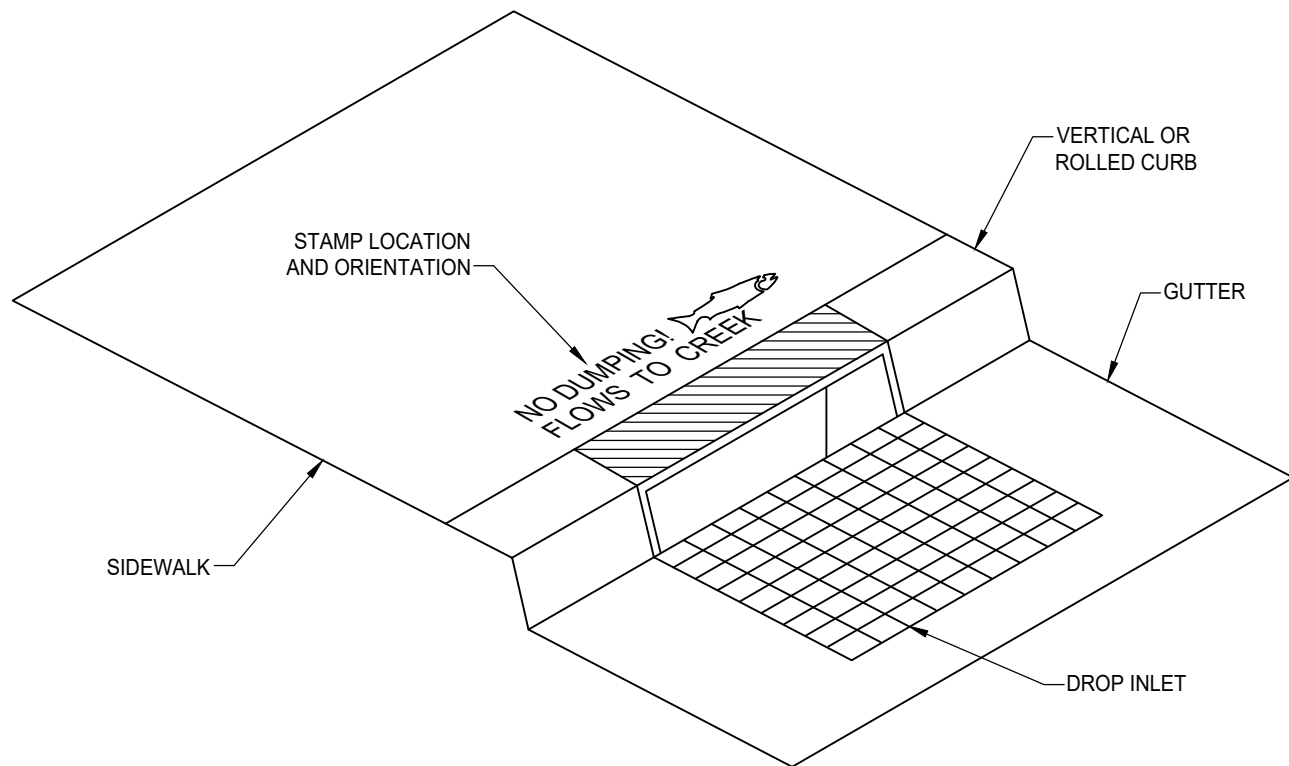

NOTES:

1. MESSAGE AND SYMBOL SHALL BE AS SHOWN ON SQ-10.2 OR AS APPROVED BY THE DIRECTOR.
2. LETTERS SHALL BE 1.5 INCHES (38 MM) IN HEIGHT. THE MESSAGE SHALL BE CENTERED ON THE BACK OF THE INLET.
3. CONCRETE SHALL BE STAMPED IN SUCH A WAY AS TO PROVIDE FOR A CLEAR AND LEGIBLE IMAGE. (APPROXIMATE DEPTH OF 0.25 INCH OR 6 MM).

DATE: 09/22/2017		NOT TO SCALE	
REVISION	BY	APPROVED	DATE

CITY OF ELK GROVE - PUBLIC WORKS

**DROP INLET CONCRETE STAMP
(SHEET 1 OF 2)**

APPROVED BY:
Paul Murock 10/24/2018
CITY ENGINEER DATE

DRAWING NUMBER
SQ - 10.1



STAMP MESSAGES AND SYMBOLS

DIMENSIONS MAY VARY AMONG THE STAMP DESIGNS SHOWN BELOW, BUT SHALL NOT EXCEED THE MAXIMUM DIMENSIONS.



DATE: 09/22/2017		NOT TO SCALE	
REVISION	BY	APPROVED	DATE

CITY OF ELK GROVE - PUBLIC WORKS

**DROP INLET CONCRETE STAMP
(SHEET 2 OF 2)**

APPROVED BY:
Paul Murbach 10/24/2018
CITY ENGINEER DATE

DRAWING NUMBER
SQ - 10.2



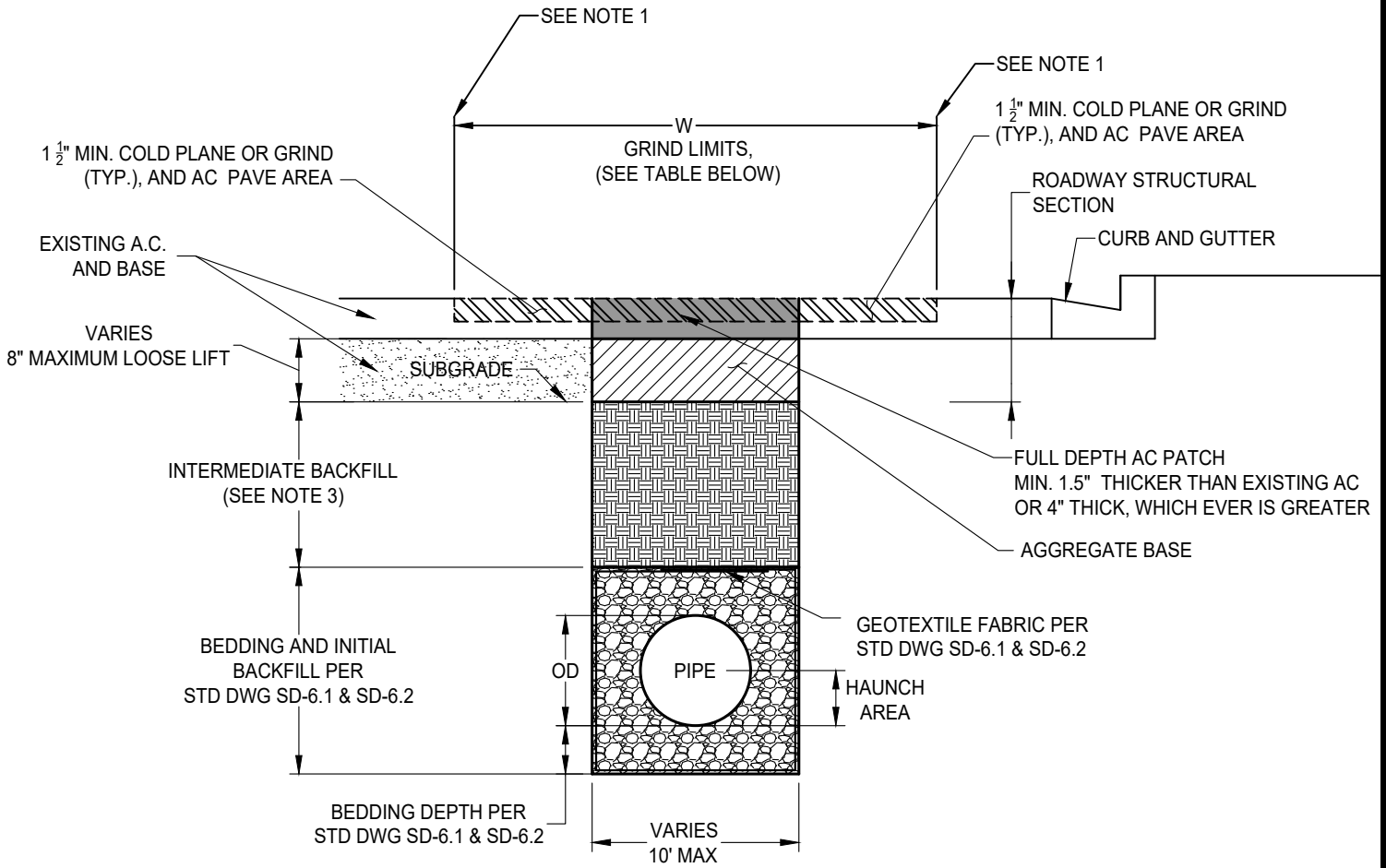

GRIND LIMITS DETAILS

PAVEMENT CONDITION PCI	W	
	ACROSS TRAFFIC (PERPENDICULAR)	ALONG TRAFFIC (LONGITUDINAL)
85-100	TRENCH + 2' EACH SIDE (10' MIN)	TRENCH + 2' EACH SIDE
70<85	TRENCH + 2' EACH SIDE (5' MIN)	TRENCH + 2' EACH SIDE (8' MIN)
50<70	TRENCH + 2' EACH SIDE (5' MIN)	TRENCH + 2' EACH SIDE (5' MIN)
<50	TRENCH + 1' EACH SIDE (5' MIN)	TRENCH + 1' EACH SIDE (4' MIN)

NOTES:

1. GRINDING/PAVEMENT JOINT SHALL BE LOCATED ALONG GUTTER LINES, LANE LINES, OR CENTER OF LANES AND SHALL NOT BE PLACED IN WHEEL LINES.
2. ENTIRE BIKE LANE SHALL BE REPAVED WHEN TRENCHING OCCURS IN BIKE LANE AREA.
3. INTERMEDIATE BACKFILL MATERIALS SHALL BE PER STD DWG SD-6.0.

DATE 02-16-2022		NOT TO SCALE	
REVISION	BY	APPROVED	DATE
01	STN	SA	02-16-2022
02	AR	JCS	12/5/2023

CITY OF ELK GROVE - PUBLIC WORKS

TRENCH BACKFILLING AND RESURFACING

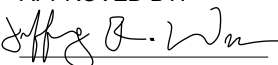
APPROVED BY:

 CITY ENGINEER DATE 04-29-2024



DRAWING NUMBER

ST - 1A

GENERAL NOTES:

1. PLANE EXISTING ASPHALT TO A 1 1/2" MIN. DEPTH.
2. A TACK COAT SHALL BE APPLIED TO THE AREA PRIOR TO PLACING NEW ASPHALT CONCRETE.
3. ASPHALT CONCRETE MIX SHALL BE APPROVED BY THE CITY PRIOR TO PLACEMENT.
4. ASPHALT CONCRETE SHALL BE SAND SEALED WITHIN 24 HOURS OF TRENCH RESURFACING.
5. TRAFFIC CONTROL PLAN SHALL BE REQUIRED. ALL TRENCH WORK IN RIGHT-OF-WAY WILL REQUIRE TRAFFIC CONTROL PLAN.
6. VIBRATORY ROLLERS SHALL BE USED ON ALL TRENCH REPAIRS IF CLASS II AGGREGATE BASE IS USED. VIBRATORY PLATES MAY ONLY BE USED WHERE APPROVED IN ADVANCE BY CITY ENGINEER.

NOTES: (FOR FABRIC)

1. AN APPROVED TACK COAT IS REQUIRED PRIOR TO PLACING NEW FABRIC.
2. NEW FABRIC IS TO OVERLAP EXISTING FABRIC A MINIMUM OF 3' ON EACH SIDE OF THE TRENCH.

NOTES: (FOR NARROW TRENCH / CDF BACKFILL)

1. CDF BACKFILL SHALL HAVE A MINIMUM 8" SLUMP
2. CDF BACKFILL SHALL BE THOROUGHLY CONSOLIDATED TO ENCASE CONDUITS. CONCRETE VIBRATORS SHALL BE USED DURING PLACEMENT OF SAND CEMENT.
3. CDF SHALL BE SCREENED OFF TO MATCH PLANED PAVEMENT GRADE.
4. ALLOW CDF BACKFILL 48 HOURS MINIMUM CURE AND DRY TIME BEFORE APPLYING ASPHALT CONCRETE.
5. IN SECONDARY, MAJOR OR PRIME ARTERIAL STREETS, TO ACCELERATE CURING TIMES PER NOTE 4, AN APPROVED SET ACCELERATING ADMIXTURE MAY BE USED WITH CITY ENGINEER'S APPROVAL.

DATE: 09/22/2017		NOT TO SCALE	
REVISION	BY	APPROVED	DATE
1	SJB	SMA	03-27-2024

CITY OF ELK GROVE - PUBLIC WORKS

GENERAL NOTES

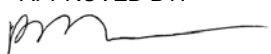
APPROVED BY:  05-28-2024

CITY ENGINEER _____ DATE _____

DRAWING NUMBER
ST - 7



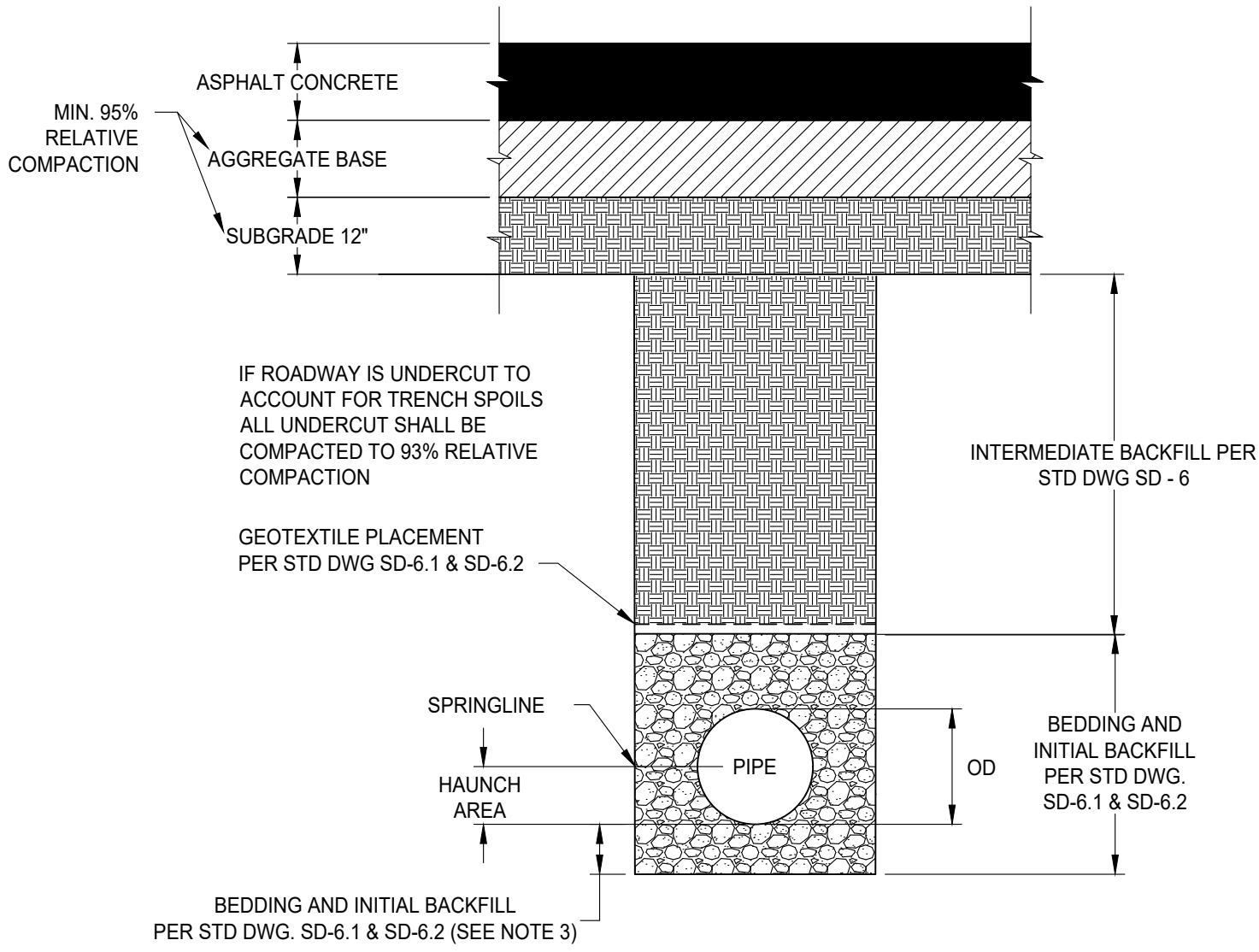



DATE 09/22/2017		NOT TO SCALE	
REVISION	BY	APPROVED	DATE
01	STN	SA	02-16-2022
02	AR	JCS	12/5/2023

CITY OF ELK GROVE - PUBLIC WORKS

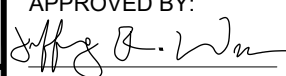
**TYPICAL TRENCH COMPACTION
DETAIL**

APPROVED BY:

 CITY ENGINEER DATE 04-29-2024

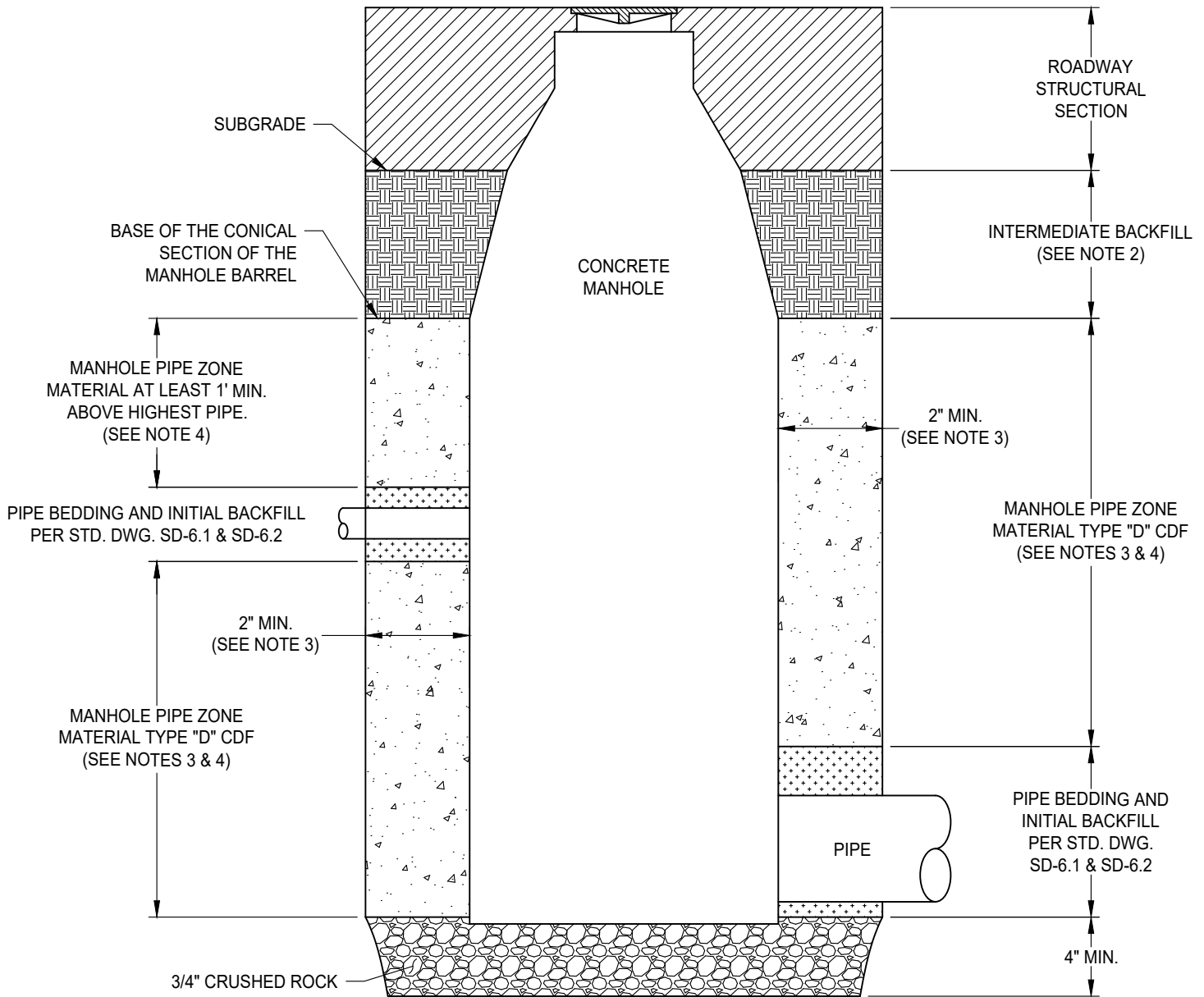
 DRAWING NUMBER
ST - 8



NOTES:

1. SEE CONSTRUCTION SPECIFICATIONS SECTION 50-15 FOR TYPE "D" CONTROLLED DENSITY FILL (CDF).
2. INTERMEDIATE BACKFILL SHALL BE PLACED PER STD. DWG. SD-6.0
3. MANHOLE PIPE ZONE MATERIAL SHALL BE TYPE "D" CDF AND SHALL EXTEND 2 FEET MINIMUM HORIZONTALLY, SURROUNDING MANHOLE BARREL OR TO THE EDGE OF THE EXCAVATION (VARIES).
4. MANHOLE PIPE ZONE MATERIAL SHALL BE TYPE "D" CDF AND SHALL EXTEND 4 FEET MINIMUM VERTICALLY, ABOVE THE TOP OF THE LOWEST ASSOCIATED PIPE OR 1 FOOT VERTICALLY ABOVE THE TOP OF THE HIGHEST ASSOCIATED PIPE, OR TO THE BASE OF CONICAL SECTION OF THE MANHOLE BARREL AND BELOW THE SUBGRADE, WHICHEVER IS GREATER (VARIES).

DATE: 09/22/2017		NOT TO SCALE	
REVISION	BY	APPROVED	DATE
1	SJB	SMA	5-01-2025

CITY OF ELK GROVE - PUBLIC WORKS

MANHOLE BACKFILL DETAIL

APPROVED BY: _____

5-08-2025
DATE

CITY ENGINEER

DRAWING NUMBER
ST - 8A



TEMPORARY

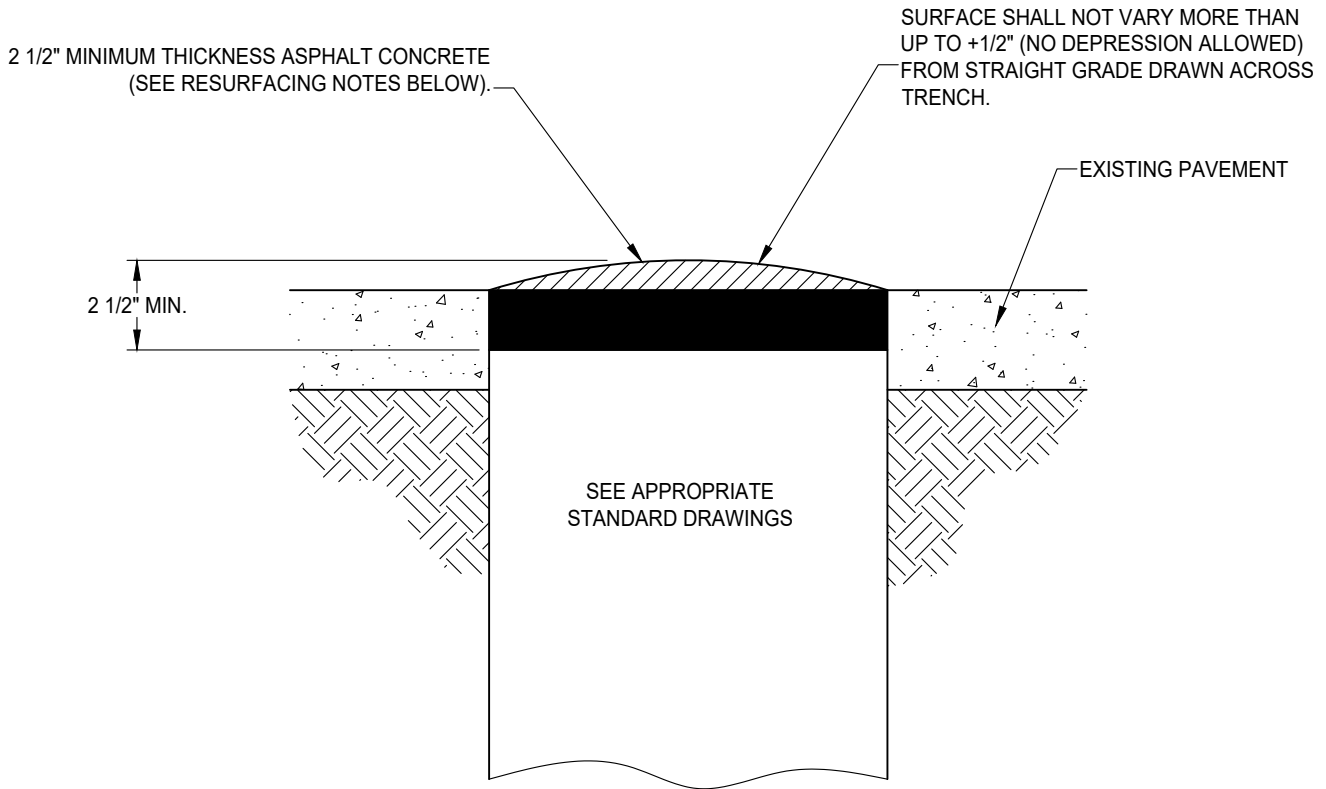

TEMPORARY RESURFACING

- A. 30 DAYS MAXIMUM ON NON-OCCUPIED RESIDENTIAL STREETS.
- B. 72 HOURS MAXIMUM ON OCCUPIED RESIDENTIAL STREETS.
- C. 48 HOURS MAXIMUM ON LOCAL COLLECTORS. MAJOR ROADS, AND PRIME ARTERIALS (HOT MIX ONLY 3/4" PG 64-16.
- D. TRAFFIC CONTROL PLAN REQUIRED.

NOTES:

1. "COLD MIX" WILL BE ALLOWED TO REMAIN AS SURFACING FOR A MAXIMUM OF 24 HOURS. EARLIER REPLACEMENT WILL BE REQUIRED IF MAINTENANCE OF THE SURFACE IS UNSATISFACTORY, SOLELY AT THE DISCRETION OF THE CITY ENGINEER OR HIS DESIGNATED REPRESENTATIVE.

DATE: 09/22/2017		NOT TO SCALE	
REVISION	BY	APPROVED	DATE

CITY OF ELK GROVE - PUBLIC WORKS

TEMPORARY TRENCH RESURFACING

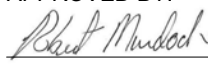
APPROVED BY:

 CITY ENGINEER 10/24/2018
 DATE

DRAWING NUMBER
ST - 9

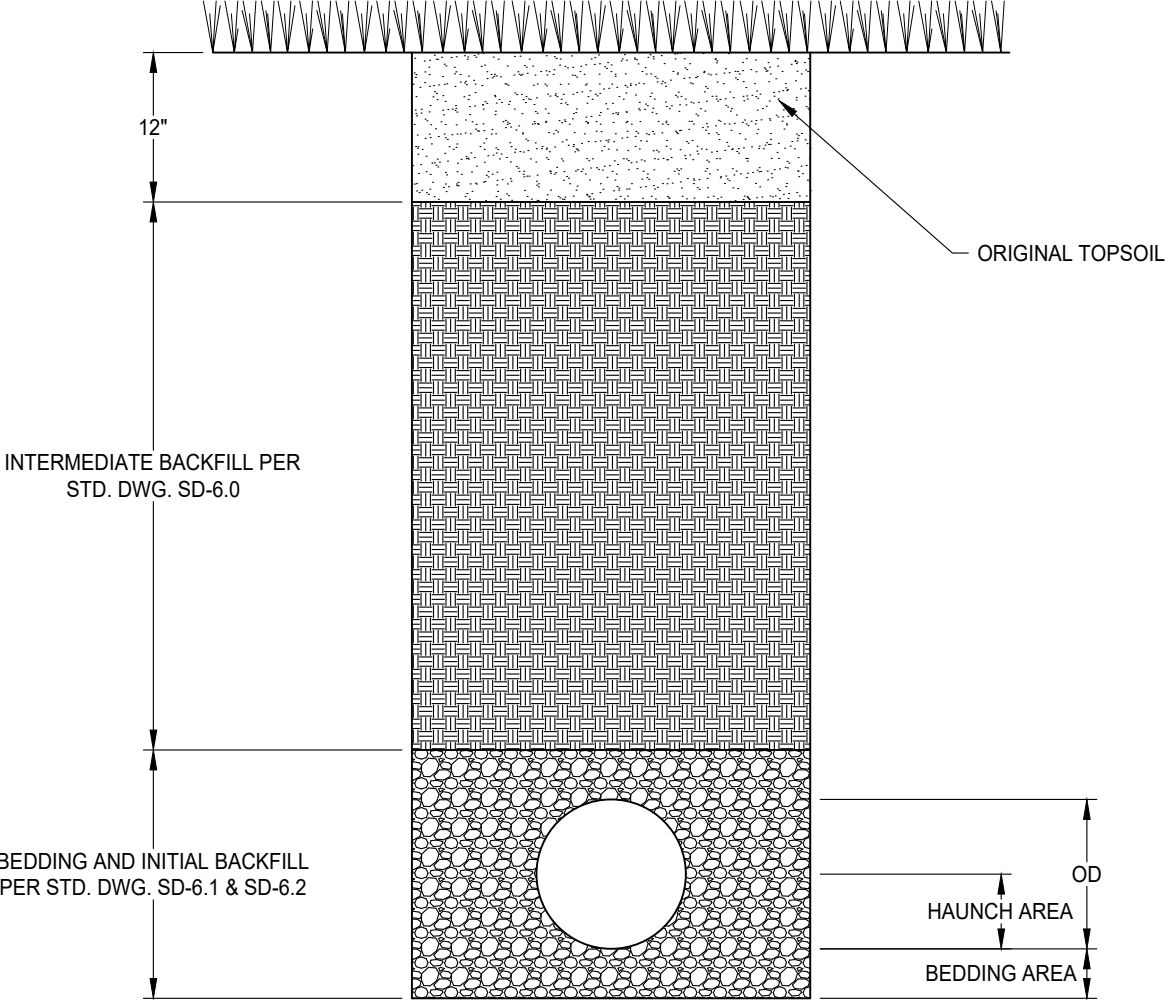

NOTES:

- 1. SEE STANDARD DRAWING SD-6.1 AND SD-6.2 FOR GEOTEXTILE REQUIREMENTS.



DATE: 09/22/2017		NOT TO SCALE	
REVISION	BY	APPROVED	DATE
1	SJB	SMA	02-28-2024

CITY OF ELK GROVE - PUBLIC WORKS

**TRENCH SECTIONS IN IMPROVED AREAS
HORTICULTURE, LAWN, OR CULTIVATED
AREAS**

APPROVED BY:
Jeffrey B. Wan 04-29-2024
CITY ENGINEER DATE

DRAWING NUMBER
ST - 10



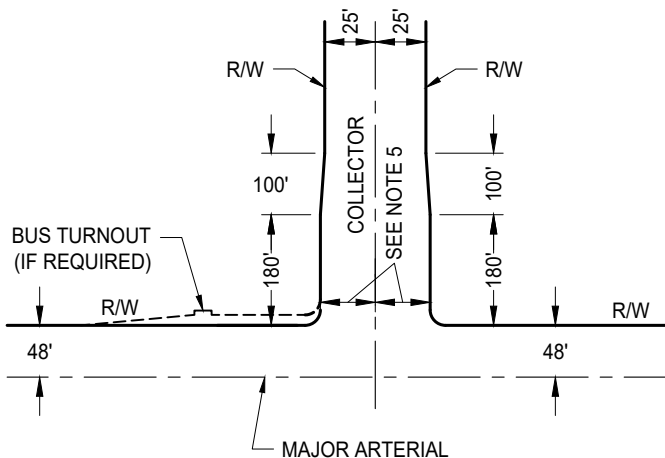
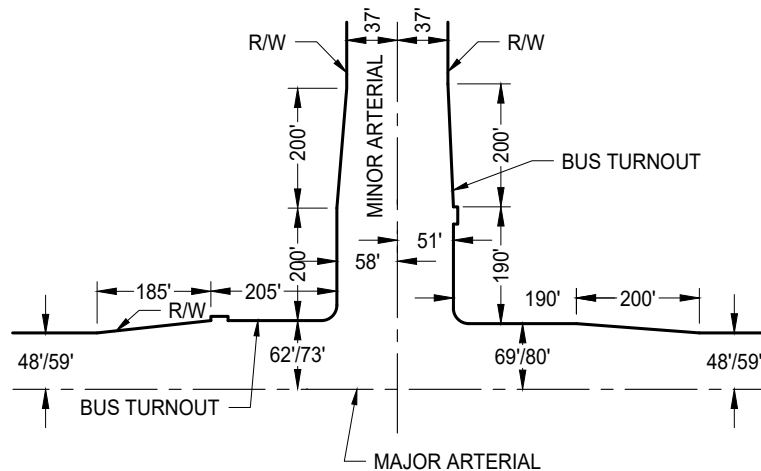
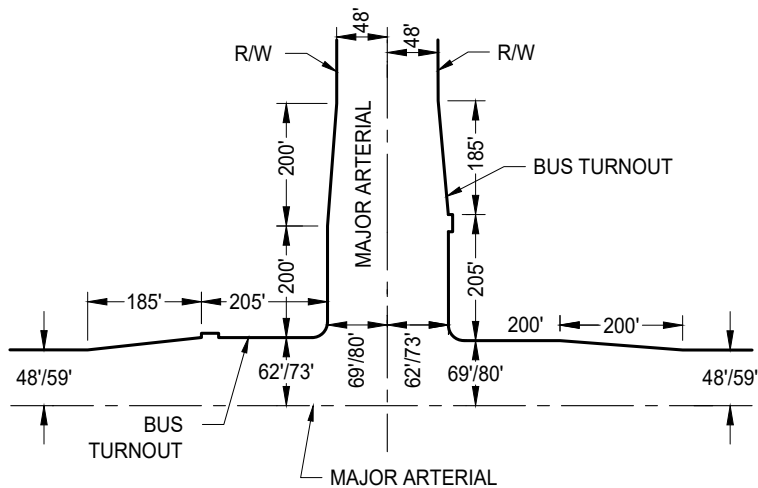

NOTES:

1. RADIUS AT CORNERS IS 33'.
2. FOR BUS TURNOUT DIMENSIONS, SEE STANDARD DRAWING ST-27
3. TYPE 2 CURB AND GUTTER SHALL BE REQUIRED WITHIN ALL CURB RETURNS, AND AT ALL BUS TURNOUTS AS SHOWN ON STANDARD DRAWINGS ST-27 AND ST-28.
4. HALF WIDTH OF 56' COLLECTOR STREETS AT APPROACH TO MAJOR STREETS SHALL BE 31' IF STREET DOES NOT HAVE BICYCLE LANES AND 35' IF IT DOES. HALF WIDTH OF 50' COLLECTOR STREETS AT APPROACH TO MAJOR STREETS SHALL BE 33' IF STREET DOES NOT HAVE BICYCLE LANES AND 37' IF IT DOES.
5. SIDEWALK SHALL BE INCLUDED AS PART OF THE RIGHT-OF-WAY WHEN ADJACENT TO THE BACK OF CURB SUCH AS AT INTERSECTIONS AND DRIVEWAYS.

DATE: 09/22/2007		NOT TO SCALE	
REVISION	BY	APPROVED	DATE
1	SJB	SMA	03-07-2025

CITY OF ELK GROVE - PUBLIC WORKS

**WIDENING DETAILS FOR
MAJOR ARTERIALS AT VARIOUS
STREET INTERSECTIONS**

APPROVED BY:

[Signature] 03-12-2025

CITY ENGINEER

DATE



DRAWING NUMBER

ST - 11

NOTES:

1. RADIUS AT CORNERS IS 33'.
2. FOR BUS TURNOUT DIMENSIONS, SEE STANDARD DRAWING ST-27.
3. TYPE 2 CURB AND GUTTER SHALL BE REQUIRED WITHIN ALL CURB RETURNS, AND AT ALL BUS TURNOUTS AS SHOWN ON STANDARD DRAWINGS ST-27 AND ST-28.
4. HALF WIDTH OF 56' COLLECTOR STREETS AT APPROACH TO MAJOR STREETS SHALL BE 31' IF STREET DOES NOT HAVE BICYCLE LANES AND 35' IF IT DOES. HALF WIDTH OF 50' COLLECTOR STREETS AT APPROACH TO MAJOR STREETS SHALL BE 33' IF STREET DOES NOT HAVE BICYCLE LANES AND 37' IF IT DOES.
5. SIDEWALK SHALL BE INCLUDED AS PART OF THE RIGHT-OF-WAY WHEN ADJACENT TO THE BACK OF CURB SUCH AS AT INTERSECTIONS AND DRIVEWAYS.

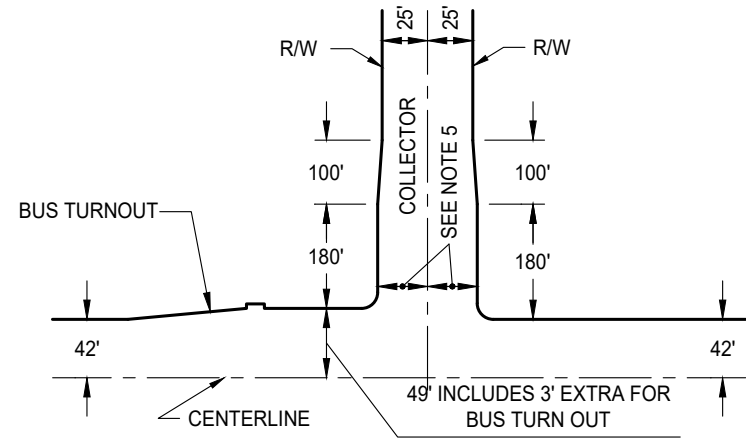

WITH BUS TURNOUT

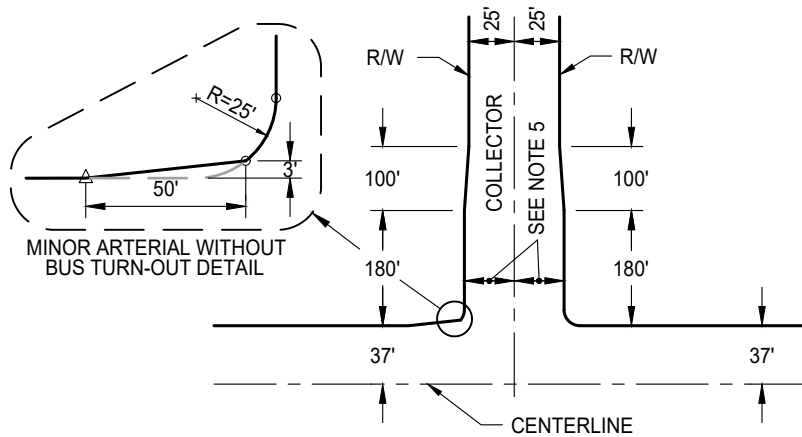

WITHOUT BUS TURNOUT

DATE 09/22/2007		NOT TO SCALE	
REVISION	BY	APPROVED	DATE
1	SJB	SMA	03-07-2025

CITY OF ELK GROVE - PUBLIC WORKS

**WIDENING DETAILS FOR
MINOR ARTERIALS AT COLLECTOR
STREET INTERSECTIONS**

APPROVED BY:

[Signature] 03-12-2025

CITY ENGINEER

DATE



DRAWING NUMBER

ST - 12B

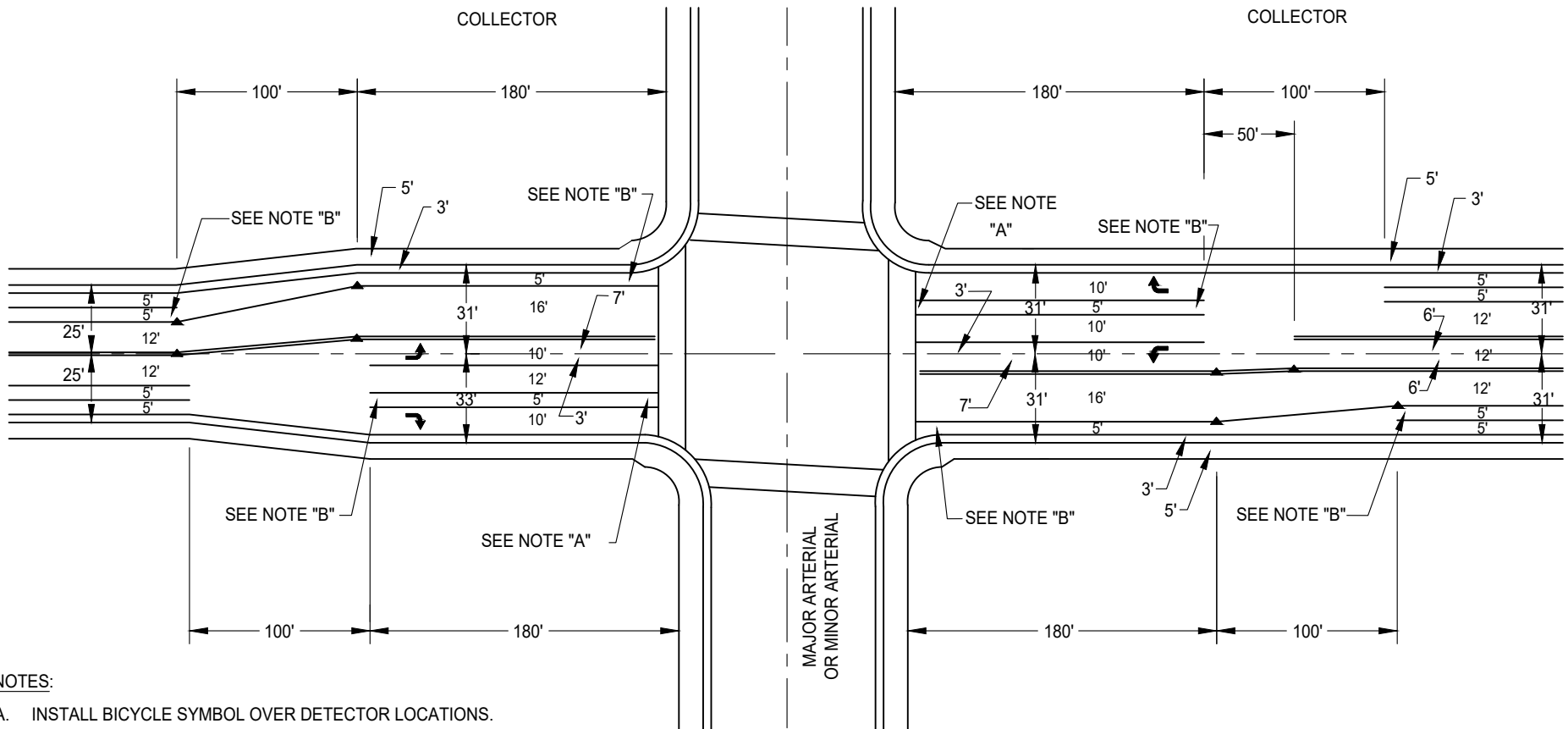

NOTES:

- A. INSTALL BICYCLE SYMBOL OVER DETECTOR LOCATIONS.
- B. INSTALL "BIKE", "LANE" AND " → " PAVEMENT LEGENDS AT THE FOLLOWING LOCATIONS:
 - APPROXIMATELY 10' PAST CROSSWALKS.
 - AT THE BEGINNING OF BICYCLE LANE ADJOINING RIGHT-TURN LANES.
- C. DIMENSIONS ARE TO CENTERLINE OF STRIPES.
- D. SIDEWALK SHALL BE INCLUDED AS PART OF THE RIGHT-OF-WAY WHEN ADJACENT TO THE BACK OF CURB SUCH AS AT INTERSECTIONS AND DRIVEWAYS.
- E. BIKE LANE MARKINGS SHALL BE IN ACCORDANCE WITH THE CURRENT VERSION OF THE CALIFORNIA MUTCD.

DATE: 09/22/2007		NOT TO SCALE	
REVISION	BY	APPROVED	DATE
1	SN	SA	07-29-2021
2	SJB	SMA	03-07-2025

CITY OF ELK GROVE - PUBLIC WORKS

**TYPICAL STRIPING FOR COLLECTOR STREETS
WITH BICYCLE LANES AT INTERSECTIONS
WITH ARTERIAL STREETS**

APPROVED BY:

03-12-2025

CITY ENGINEER

DATE



DRAWING NUMBER

ST - 13

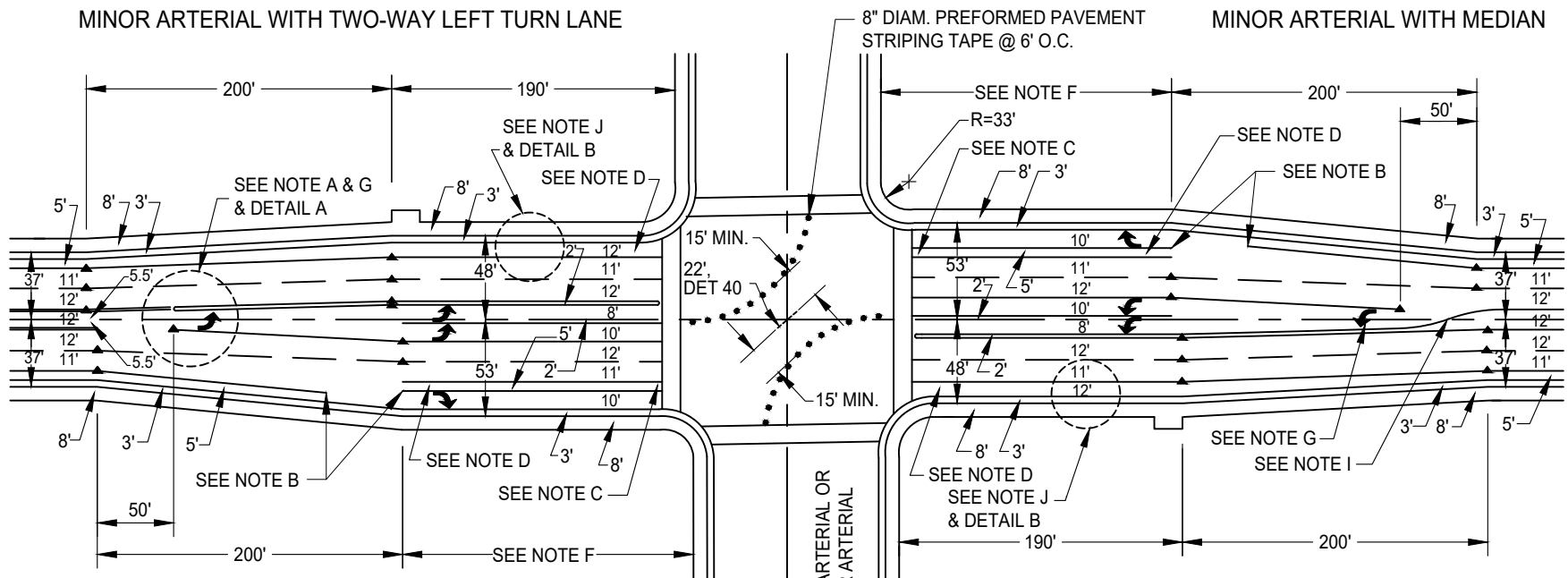

NOTES:

- A. END OF RAISED MEDIAN MAY BE MOVED AS NECESSARY FOR DRIVEWAY LOCATIONS. SEE IMPROVEMENT STANDARD SECTION 4-7 (G)
- B. BIKE LANE STRIPE TO BE DISCONTINUED APPROX. 100' FROM START OF RIGHT-TURN LANE AND RESUMED AT BEGINNING OF RIGHT-TURN-ONLY LANE.
- C. INSTALL BICYCLE SYMBOL OVER DETECTOR LOCATIONS.
- D. INSTALL "BIKE", "LANE" AND "➔" PAVEMENT LEGENDS AS PER THE CURRENT VERSION OF THE CALIFORNIA MUTCD AT THE FOLLOWING LOCATIONS:
 - APPROXIMATELY 10' PAST CROSSWALKS;
 - AT BEGINNING OF BICYCLE LANE ADJOINING RIGHT-TURN LANES.
- E. DIMENSIONS ARE TO CENTERLINE OF STRIPES.
- F. LENGTH OF APPROACH ADJACENT TO RIGHT TURN LANE SHALL BE: 200' APPROACHING A MAJOR ARTERIAL 190' APPROACHING A MINOR ARTERIAL.
- G. DIRECTIONAL ARROWS ARE PROVIDED AT THE BEGINNING OF ALL TURN POCKETS. INSTALL ADDITIONAL ARROWS IF LENGTH OF TURN POCKET EXCEEDS 250 FT.
- H. ALL PAVEMENT MARKINGS AND STRIPING AS PER THE CURRENT VERSION OF THE CALIFORNIA MUTCD.
- I. 90' BAY TAPER AS PER THE CURRENT CALTRANS HDM.

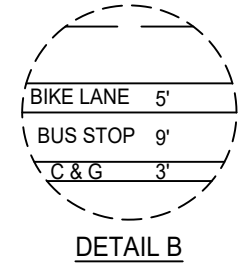
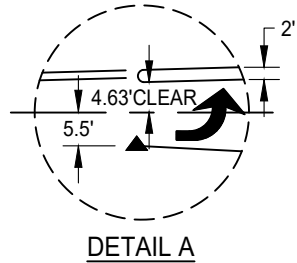

- J. SIDEWALK SHALL BE INCLUDED AS PART OF THE RIGHT-OF-WAY WHEN ADJACENT TO THE BACK OF CURB SUCH AS AT INTERSECTIONS AND DRIVEWAYS.
- K. IF THE DRIVEWAY, APPROVED BY PUBLIC WORKS, IS WITHIN THE EXPANDED INTERSECTION, ADDITIONAL 3 FEET RIGHT-OF-WAY WILL BE REQUIRED. SEE DETAIL "B".
- L. BIKE LANE MARKINGS SHALL BE IN ACCORDANCE WITH THE CURRENT VERSION OF THE CALIFORNIA MUTCD.

DATE: 09/22/2007		NOT TO SCALE	
REVISION	BY	APPROVED	DATE
1	SN	SA	07-29-2021
2	SJB	SMA	03-07-2025

CITY OF ELK GROVE - PUBLIC WORKS

TYPICAL STRIPING FOR MINOR ARTERIAL INTERSECTIONS WITH ARTERIALS

APPROVED BY: _____ 03-12-2025
 CITY ENGINEER DATE

DRAWING NUMBER
ST - 14A



MAJOR ARTERIAL

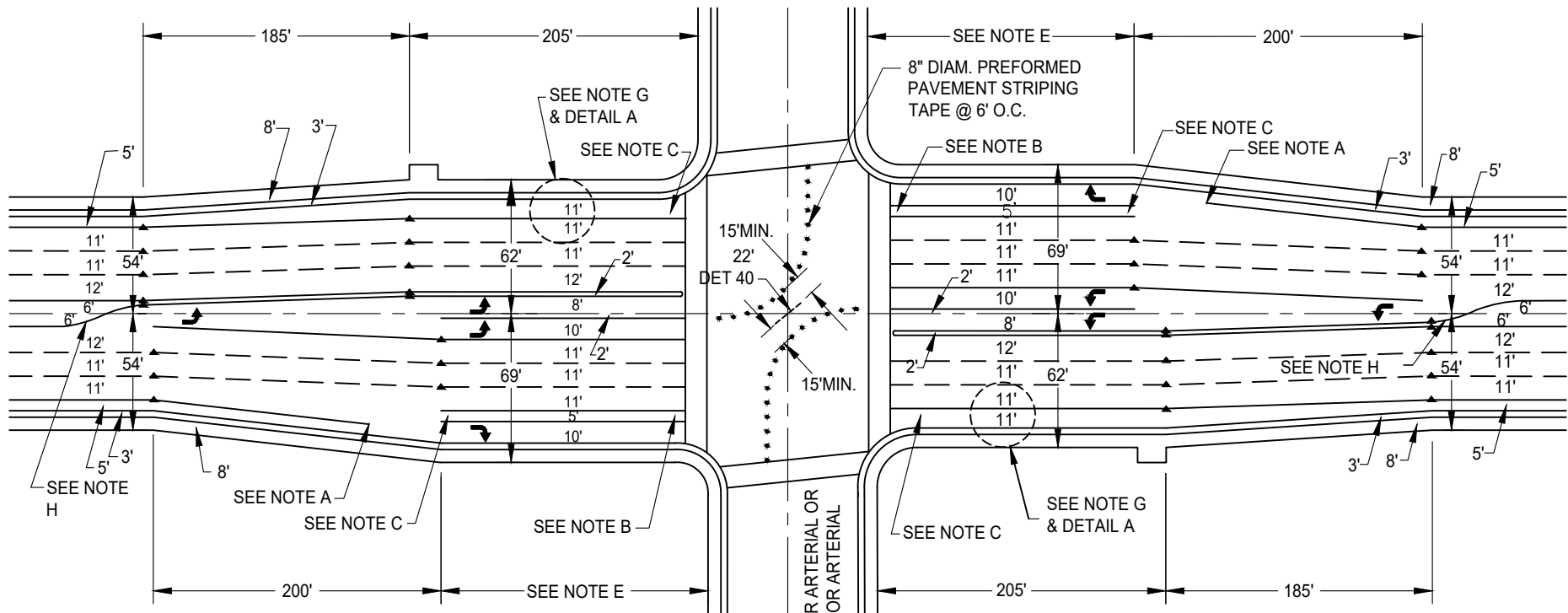

NOTES:

- A. BIKE LANE STRIPE TO BE DISCONTINUED APPROXIMATELY 100' FROM RIGHT-TURN LANE AND RESUMED AT BEGINNING OF RIGHT-TURN ONLY LANE.
- B. INSTALL BICYCLE SYMBOL OVER DETECTOR LOCATIONS.
- C. INSTALL "BIKE", "LANE" AND " → " PAVEMENT LEGENDS AT THE FOLLOWING LOCATIONS:
 - APPROXIMATELY 10' PAST CROSSWALKS.
 - AT THE BEGINNING OF BICYCLE LANE ADJOINING RIGHT-TURN LANES.
- D. DIMENSIONS ARE TO CENTERLINE OF STRIPES.
- E. LENGTH OF APPROACH ADJACENT TO RIGHT TURN LANE SHALL BE: 200' APPROACHING A MAJOR ARTERIAL. 190' APPROACHING A MINOR ARTERIAL.
- F. SIDEWALK SHALL BE INCLUDED AS PART OF THE RIGHT-OF-WAY WHEN ADJACENT TO THE BACK OF CURB SUCH AS AT INTERSECTIONS AND DRIVEWAYS.
- G. IF THE DRIVEWAY, APPROVED BY PUBLIC WORKS, IS WITHIN THE EXPANDED INTERSECTION, ADDITIONAL 3 FEET RIGHT-OF-WAY WILL BE REQUIRED. SEE DETAIL A.
- H. 90° BAY TAPER AS PER THE CURRENT CALTRANS HDM.
- I. BIKE LANE MARKINGS SHALL BE IN ACCORDANCE WITH THE CURRENT VERSION OF THE CALIFORNIA MUTCD.

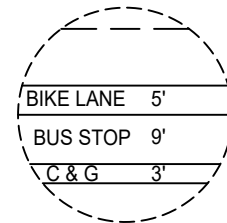

DETAIL A

DATE: 09/22/2007		NOT TO SCALE	
REVISION	BY	APPROVED	DATE
1	SN	SA	07-29-2021
2	SJB	SMA	03-07-2025

CITY OF ELK GROVE - PUBLIC WORKS

TYPICAL STRIPING FOR MAJOR ARTERIAL INTERSECTIONS WITH ARTERIALS

APPROVED BY:

[Signature] 03-12-2025
CITY ENGINEER DATE



DRAWING NUMBER

ST - 15A

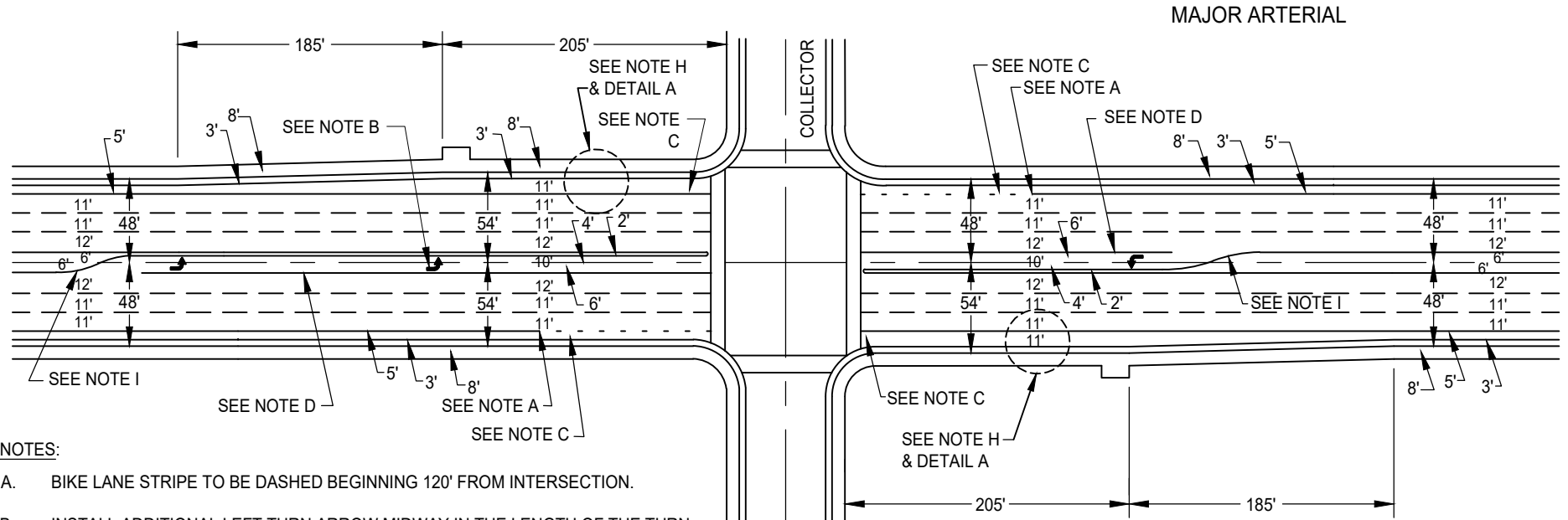

NOTES:

- A. BIKE LANE STRIPE TO BE DASHED BEGINNING 120' FROM INTERSECTION.
- B. INSTALL ADDITIONAL LEFT TURN ARROW MIDWAY IN THE LENGTH OF THE TURN LANE IF IT EXCEEDS 250'.
- C. INSTALL "BIKE", "LANE" AND " " PAVEMENT LEGENDS AS PER THE CURRENT VERSION OF CALIFORNIA MUTCD AT THE FOLLOWING LOCATIONS:
 - APPROXIMATELY 10' PAST CROSSWALKS;
 - BEFORE START OF DASHED BICYCLE LANE STRIPING.
- D. LENGTH OF TURN POCKET IS TO BE SIZED ACCORDING TO TRAFFIC NEEDS. 180' MIN. SEE 3-10 H OF TRANSPORTATION DIVISION DESIGN PRACTICE GUIDE. AND DIRECTIONAL ARROWS ARE PROVIDED AT THE BEGINNING OF ALL TURN POCKETS. IF POCKET IS LONGER THAN 100 FT. ADDITIONAL ARROWS SHALL BE PLACED AT THE END.
- E. DIMENSIONS ARE TO CENTERLINE OF STRIPES.
- F. ALL PAVEMENT MARKINGS AND STRIPING AS PER THE CURRENT VERSION OF THE CALIFORNIA MUTCD.
- G. SIDEWALK SHALL BE INCLUDED AS PART OF THE RIGHT-OF-WAY WHEN ADJACENT TO THE BACK OF CURB SUCH AS AT INTERSECTIONS AND DRIVEWAYS.
- H. IF THE DRIVEWAY, APPROVED BY PUBLIC WORKS, IS WITHIN THE EXPANDED INTERSECTION, ADDITIONAL 3 FEET RIGHT OF WAY WILL BE REQUIRED. SEE DETAIL A.
- I. 90' BAY TAPER AS PER THE CURRENT CALTRANS HDM.
- J. BIKE LANE MARKINGS SHALL BE IN ACCORDANCE WITH THE CURRENT VERSION OF THE CALIFORNIA MUTCD.

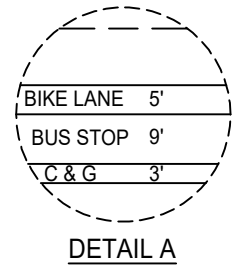

DATE: 09/22/2007		NOT TO SCALE	
REVISION	BY	APPROVED	DATE
1	SN	SA	07-29-2021
2	SJB	SMA	03-07-2025

CITY OF ELK GROVE - PUBLIC WORKS

TYPICAL STRIPING FOR MAJOR ARTERIAL INTERSECTIONS WITH COLLECTORS

APPROVED BY: _____
CITY ENGINEER DATE

03-12-2025

DRAWING NUMBER
ST - 15B

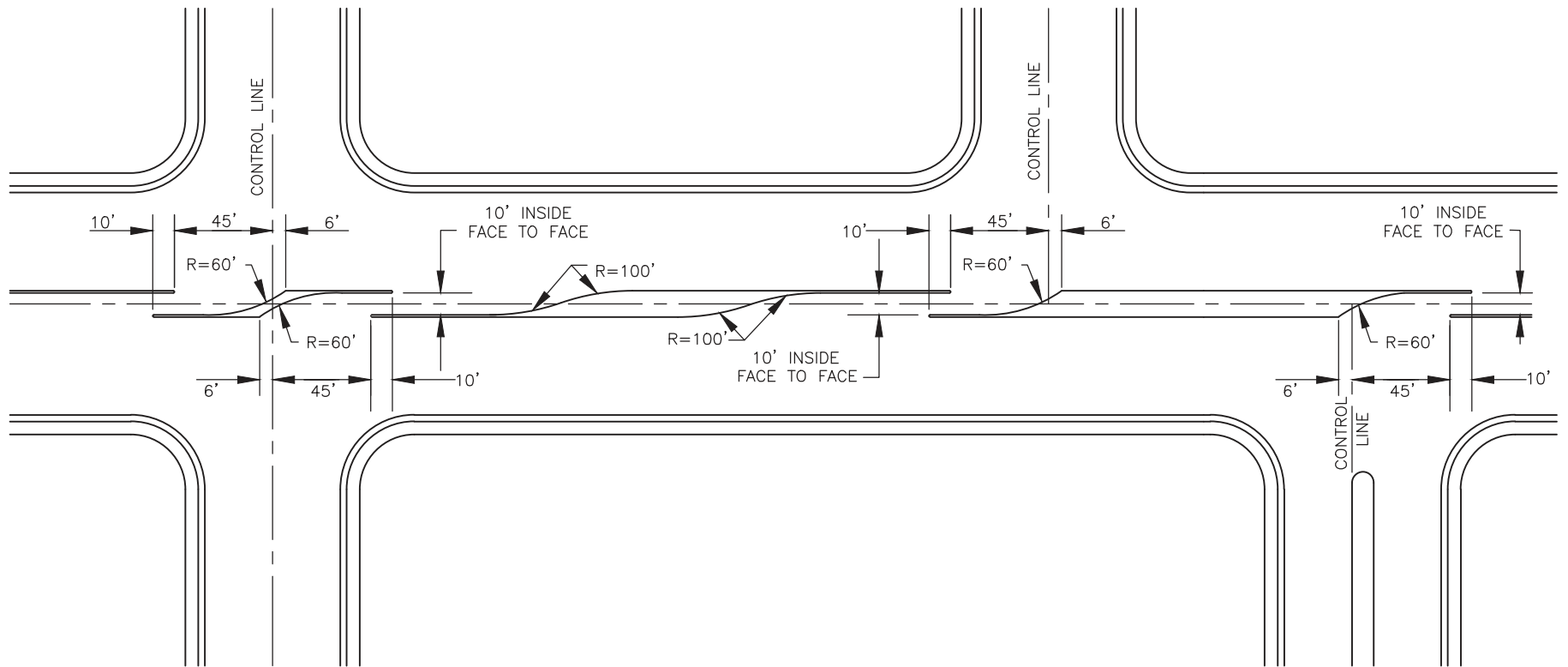

DATE: 09/22/2007		NOT TO SCALE	
REVISION	BY	APPROVED	DATE

CITY OF ELK GROVE - PUBLIC WORKS

**TYPICAL RAISED ISLAND DESIGNS
FOR LIMITING ACCESS**

APPROVED BY:
Robert M. ...
CITY ENGINEER

10/24/2018
DATE

DRAWING NUMBER
ST - 16



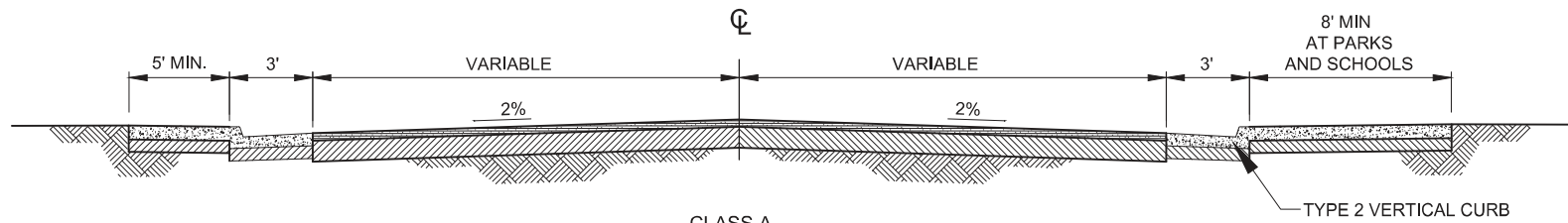

CLASS A
 CLASS B (SAME AS CLASS A EXCEPT SIDEWALKS MAY BE OMITTED)

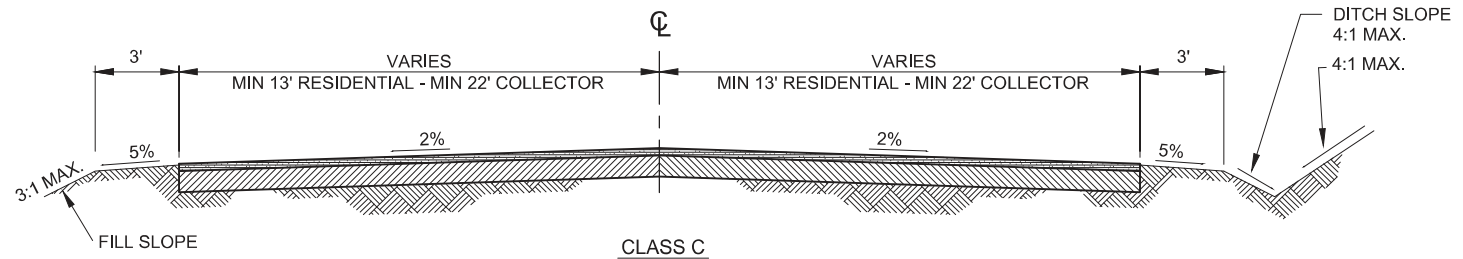

CLASS C

DATE: 09/22/2007		NOT TO SCALE	
REVISION	BY	APPROVED	DATE

CITY OF ELK GROVE - PUBLIC WORKS

**TYPICAL SECTIONS
 STREET CLASSES
 "A", "B" & "C"**

APPROVED BY:
Paul M. ...
 CITY ENGINEER

10/24/2018
 DATE

DRAWING NUMBER
ST - 17



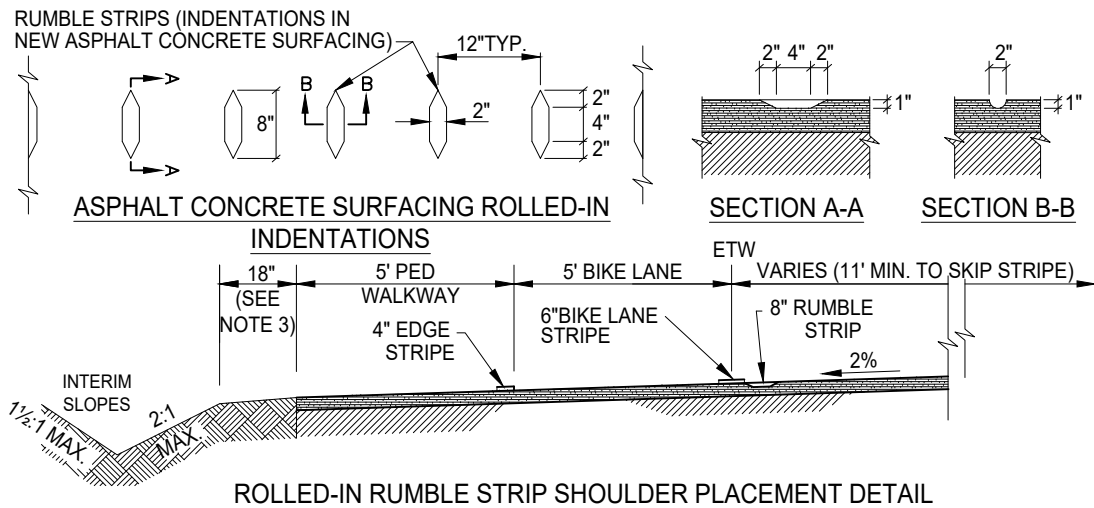
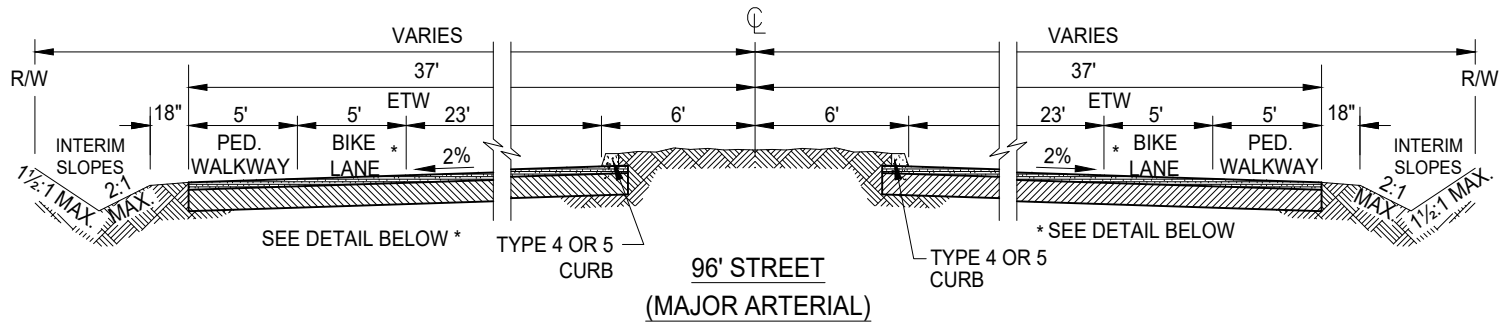

NOTES:

1. RUMBLE STRIP SHALL STOP 120' FROM THE C.R. ON THE MAJOR ROAD APPROACHING ENTERING SIDE STREETS, AND BEGIN AT C.R. ON THE MAJOR ROAD DEPARTING ENTERING SIDE STREETS.
2. POSITION BIKE LANE LEGENDS BETWEEN RUMBLE STRIP AND EDGE LINE STRIPE.
3. EARTHEN SHOULDER MAY BE ELIMINATED IF SHOULDER CONFLICTS WITH TREES OR RIGHT-OF-WAY LIMITS AND FULL DEPTH ASPHALT SECTION IS USED.

DATE 09/22/2007		NOT TO SCALE	
REVISION	BY	APPROVED	DATE
1	SJB	SMA	03-07-2025

CITY OF ELK GROVE - PUBLIC WORKS

**TYPICAL SECTIONS INTERIM IMPROVEMENTS
FOR MAJOR ARTERIAL STREETS WITH
ROLLED-IN RUMBLE STRIPS**

APPROVED BY: _____ 03-12-2025
CITY ENGINEER DATE

DRAWING NUMBER
ST - 17A



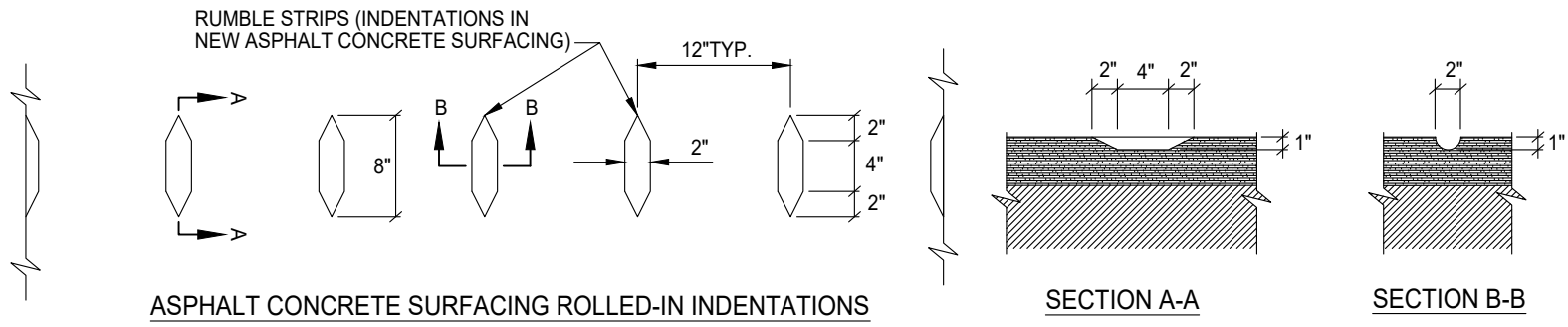

ASPHALT CONCRETE SURFACING ROLLED-IN INDENTATIONS

SECTION A-A

SECTION B-B

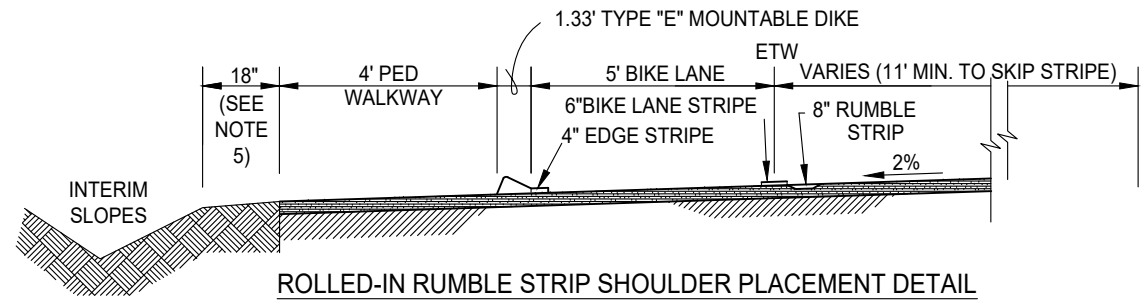

ROLLED-IN RUMBLE STRIP SHOULDER PLACEMENT DETAIL

NOTES :

1. ROLLED-IN RUMBLE STRIPS SHALL BE USED WHERE REQUIRED BY THE DIRECTOR OF THE DEPARTMENT OF TRANSPORTATION.
2. ROLLED-IN RUMBLE STRIPS MAY BE USED ON ROADWAYS THAT ARE DESIGNATED FOR 80' OR MORE OF RIGHT-OF-WAY AND ARE CONSTRUCTED WITH INTERIM IMPROVEMENTS (WITHOUT CURB & GUTTER).
3. RUMBLE STRIP SHALL STOP 120' FROM THE C.R. ON THE MAJOR ROAD APPROACHING ENTERING SIDE STREETS, AND BEGIN AT C.R. ON THE MAJOR ROAD DEPARTING ENTERING SIDE STREETS.
4. POSITION BIKE LANE LEGENDS BETWEEN RUMBLE STRIP AND EDGE LINE STRIPE.
5. EARTHEN SHOULDER MAY BE ELIMINATED IF SHOULDER CONFLICTS WITH TREES OR RIGHT-OF-WAY LIMITS AND FULL DEPTH ASPHALT SECTION IS USED
6. TYPE "E" MOUNTABLE DIKE PER CALTRANS STD. PLANS DRAWING A-87B.

DATE: 09/22/2007		NOT TO SCALE	
REVISION	BY	APPROVED	DATE

CITY OF ELK GROVE - PUBLIC WORKS

**ROLLED-IN RUMBLE STRIPS
FOR INTERIM ROADWAY
IMPROVEMENTS**

APPROVED BY:
Paul Murock
CITY ENGINEER

10/24/2018
DATE

DRAWING NUMBER
ST - 17B



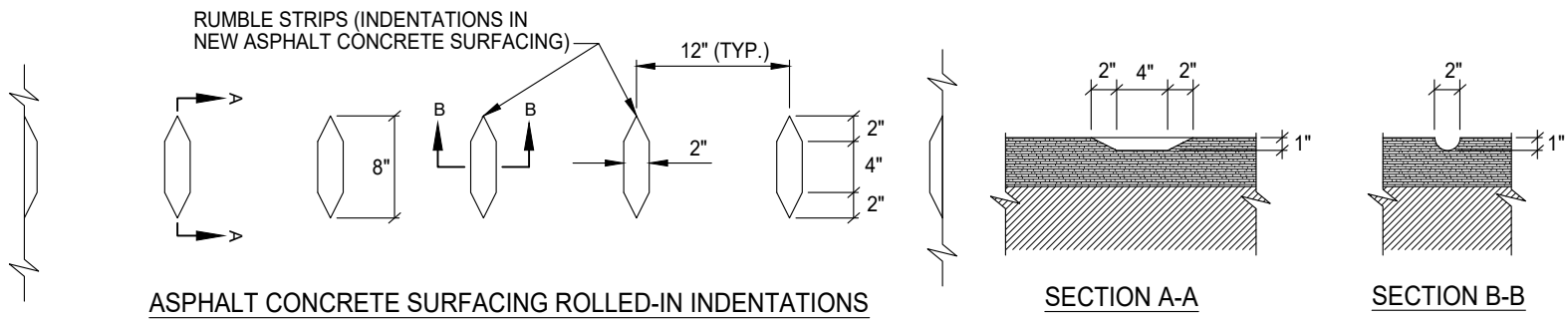

ASPHALT CONCRETE SURFACING ROLLED-IN INDENTATIONS

SECTION A-A

SECTION B-B

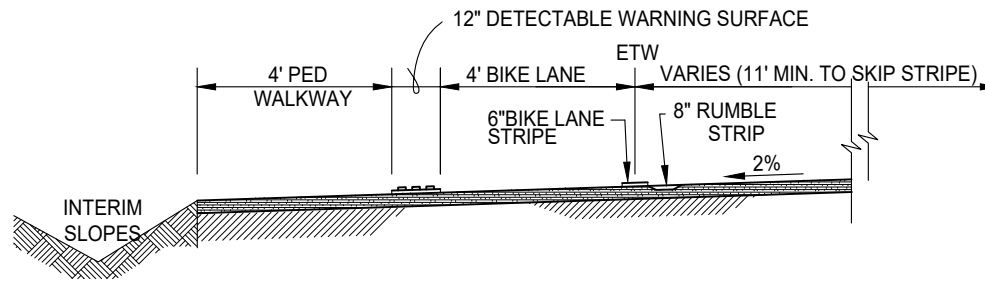

ROLLED-IN RUMBLE STRIP SHOULDER PLACEMENT DETAIL

NOTES:

1. ROLLED-IN RUMBLE STRIPS SHALL BE USED WHERE REQUIRED BY THE DIRECTOR OF THE DEPARTMENT OF TRANSPORTATION.
2. ROLLED-IN RUMBLE STRIPS MAY BE USED ON ROADWAYS THAT ARE DESIGNATED FOR 80' OR MORE OF RIGHT-OF-WAY AND ARE CONSTRUCTED WITH INTERIM IMPROVEMENTS (WITHOUT CURB & GUTTER).
3. RUMBLE STRIP SHALL STOP 120' FROM THE C.R. ON THE MAJOR ROAD APPROACHING ENTERING SIDE STREETS, AND BEGIN AT C.R. ON THE MAJOR ROAD DEPARTING ENTERING SIDE STREETS.
4. POSITION BIKE LANE LEGENDS BETWEEN RUMBLE STRIP AND EDGE LINE STRIPE.
5. EARTHEN SHOULDER MAY BE ELIMINATED IF SHOULDER CONFLICTS WITH TREES OR RIGHT-OF-WAY LIMITS AND FULL DEPTH ASPHALT SECTION IS USED.

DATE: 09/22/2007		NOT TO SCALE	
REVISION	BY	APPROVED	DATE

CITY OF ELK GROVE - PUBLIC WORKS

**ROLLED-IN RUMBLE STRIPS
FOR INTERIM ROADWAY
IMPROVEMENTS**

APPROVED BY:
Paul Murock
CITY ENGINEER

10/24/2018
DATE

DRAWING NUMBER
ST - 17C



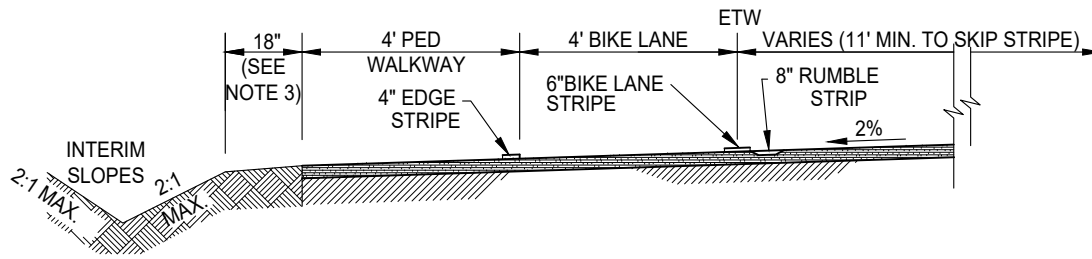
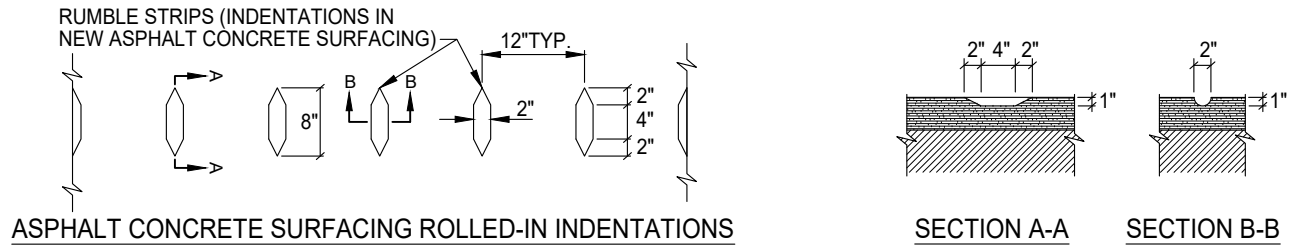

NOTES:

1. RUMBLE STRIP SHALL STOP 120' FROM THE C.R. ON THE MAJOR ROAD APPROACHING ENTERING SIDE STREETS, AND BEGIN AT C.R. ON THE MAJOR ROAD DEPARTING ENTERING SIDE STREETS.
2. POSITION BIKE LANE LEGENDS BETWEEN RUMBLE STRIP AND EDGE LINE STRIPE.
3. EARTHEN SHOULDER MAY BE ELIMINATED IF SHOULDER CONFLICTS WITH TREES OR RIGHT-OF-WAY LIMITS AND FULL DEPTH ASPHALT SECTION IS USED.

DATE: 09/22/2007		NOT TO SCALE	
REVISION	BY	APPROVED	DATE

CITY OF ELK GROVE - PUBLIC WORKS

TYPICAL SECTIONS INTERIM IMPROVEMENTS FOR SPECIAL THOROUGHFARE AND THOROUGHFARE STREETS WITH ROLLED-IN RUMBLE STRIPS

APPROVED BY:
Paul Murock
CITY ENGINEER

10/24/2018
DATE

DRAWING NUMBER
ST - 17D



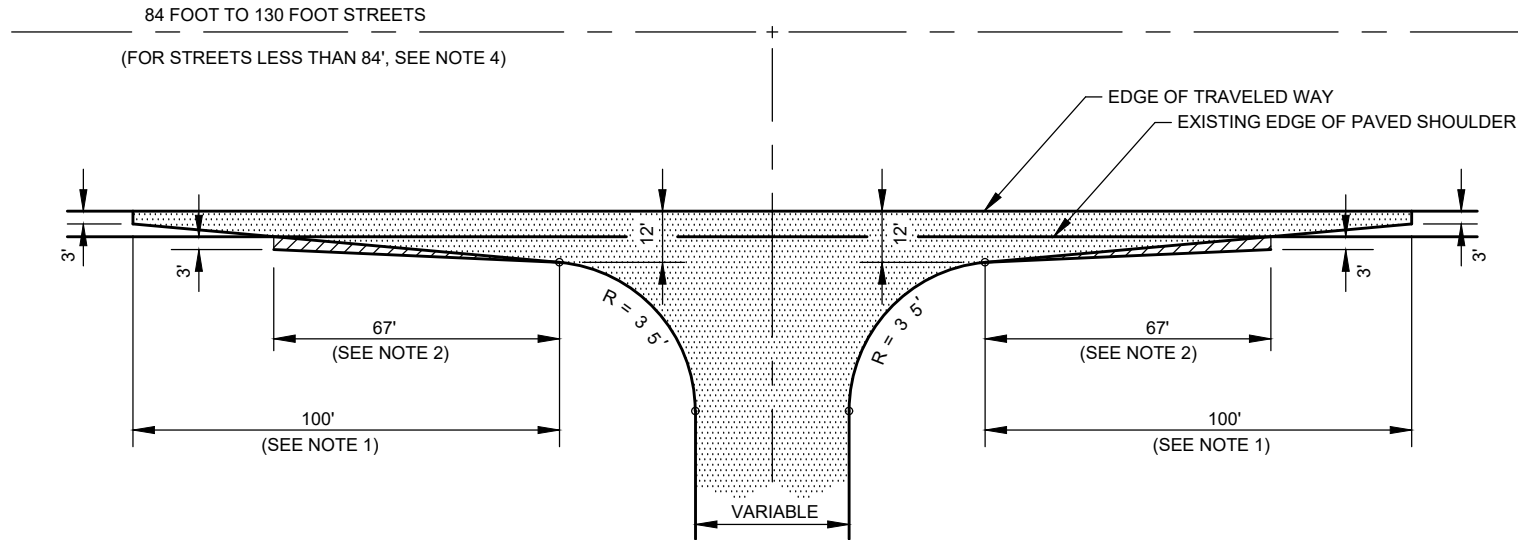

NOTES:

1. USE 100' PAVEMENT TAPER SECTION WHEN MAJOR STREET SHOULDER IS UNPAVED OR SEAL COATED, OR WHERE PAVED SHOULDER IS LESS THAN 4' WIDE.
2. USE 67' PAVEMENT TAPER SECTION WHEN MAJOR STREET SHOULDER IS FULLY PAVED, AND A MINIMUM OF 4' WIDE.
3. FULL ROADBED STRUCTURAL SECTION TO BE PLACED IN ACCORDANCE WITH CITY STANDARDS FOR AREA TO BE PAVED.
4. PAVEMENT TAPER SECTION MAY BE DELETED WHERE NEW STREET INTERSECTS WITH MINOR OR COLLECTOR STREETS.

DATE: 09/22/2007		NOT TO SCALE	
REVISION	BY	APPROVED	DATE

CITY OF ELK GROVE - PUBLIC WORKS

**CLASS "C"
STREET INTERSECTION**

APPROVED BY:
Paul Murock
CITY ENGINEER

10/24/2018
DATE

DRAWING NUMBER
ST - 18



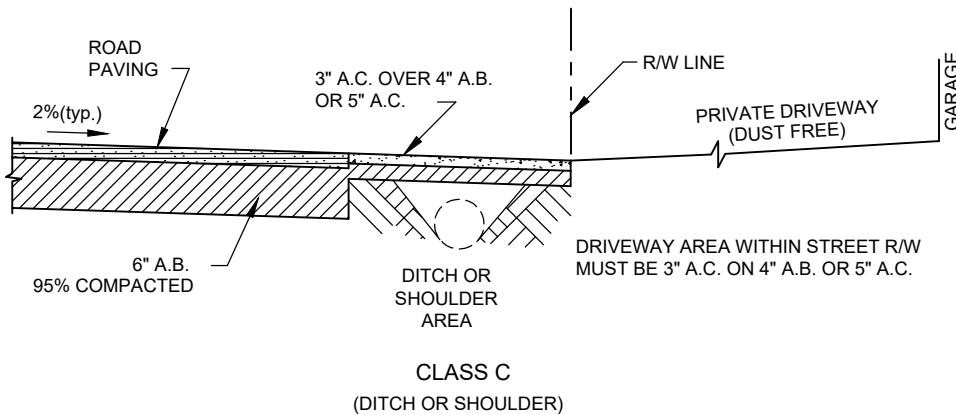
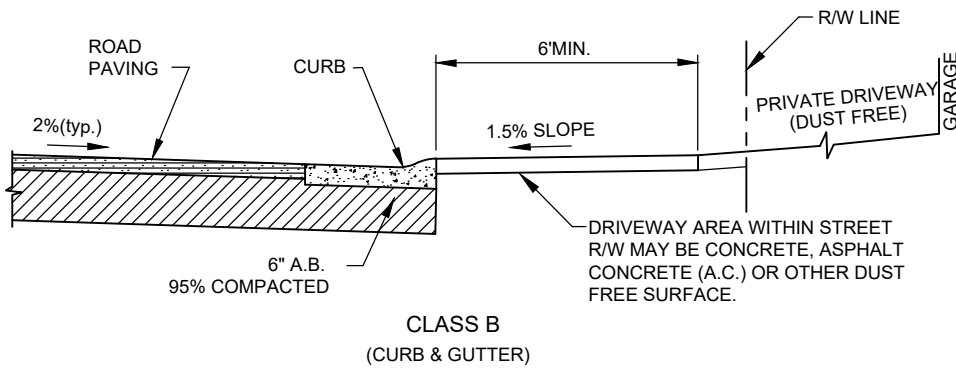
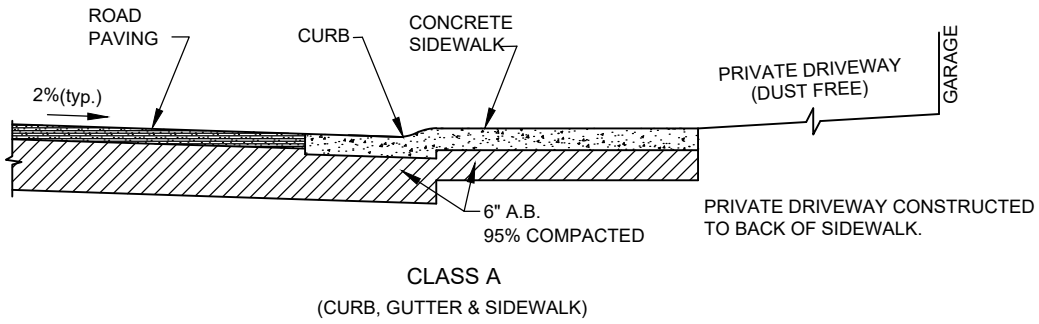

NOTE:

1. SEE CITY OF ELK GROVE IMPROVEMENT STANDARDS SECTION 4-7 FOR DRIVEWAY REQUIREMENTS.

DATE: 09/22/2017		NOT TO SCALE	
REVISION	BY	APPROVED	DATE

CITY OF ELK GROVE - PUBLIC WORKS

**TYPICAL STREET SECTIONS
AT RESIDENTIAL DRIVEWAYS**

APPROVED BY:

Paul Murock

10/24/2018

CITY ENGINEER

DATE



DRAWING NUMBER

ST - 19

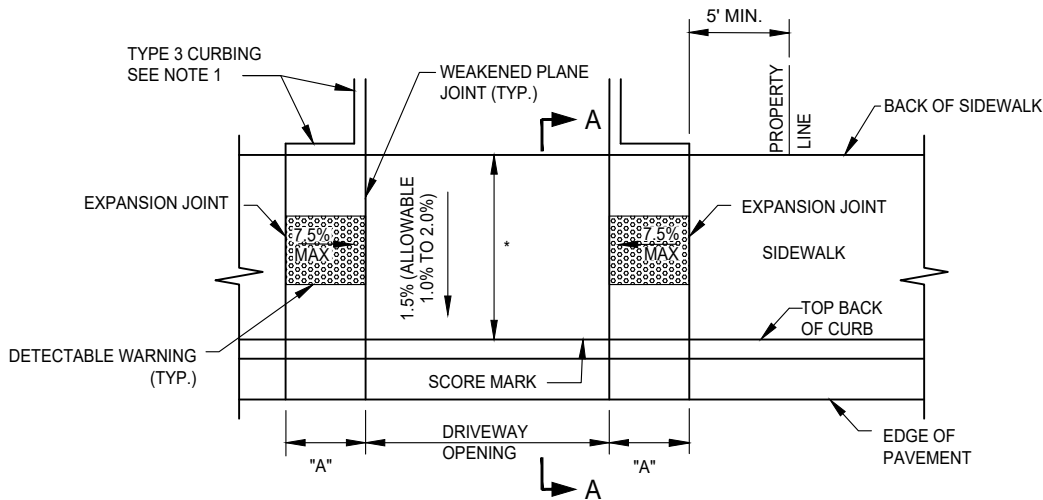
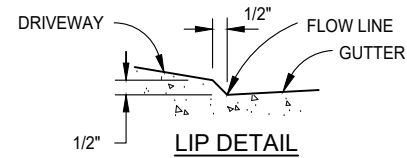
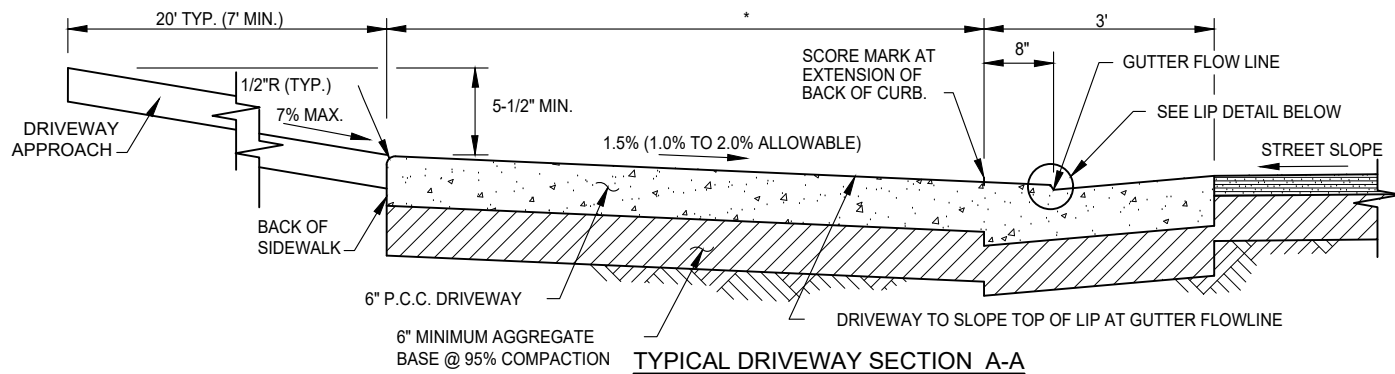

SLOPE OF GUTTER	"A" (APPROX. LENGTH)
0.25% TO 0.65%	6'-0"
> 0.65% TO 1.75%	7'-0"
> 1.75% TO 2.55%	8'-0"
> 2.55% TO 3.20%	9'-0"
> 3.20% TO 3.70%	10'-0"
> 3.70%	SEE NOTE 2

NOTES:

1. TYPE 3 CURBING ON SITE SHALL EXTEND TO WHERE THE DRIVEWAY APPROACH IS A MINIMUM OF FOUR INCHES ABOVE THE BACK OF SIDEWALK ELEVATION AT THE DRIVEWAY.
2. LENGTH OF DRIVEWAY FLAIR ON STREETS STEEPER THAN 3.70% SHALL REQUIRE SPECIAL APPROVAL BY THE CITY ENGINEER.
3. A 1/2-INCH CONCRETE BATTER SHALL BE PLACED ON ALL CURB LIPS.
4. SEE STD. DWG. AR-4.7 FOR ELEMENTS NOT SHOWN HEREON. * DRIVEWAY APRON MATCHES SIDEWALK WIDTH

DATE 09/22/2007		NOT TO SCALE	
REVISION	BY	APPROVED	DATE
01	LM	TW	07/18/2019
02	STN	JRW	02/16/2021
03	SJB	SMA	03/27/2024

CITY OF ELK GROVE - PUBLIC WORKS

**COMMERCIAL DRIVEWAYS
TYPE A-6**

APPROVED BY:

 05-28-2024

CITY ENGINEER

DATE



DRAWING NUMBER

ST - 20

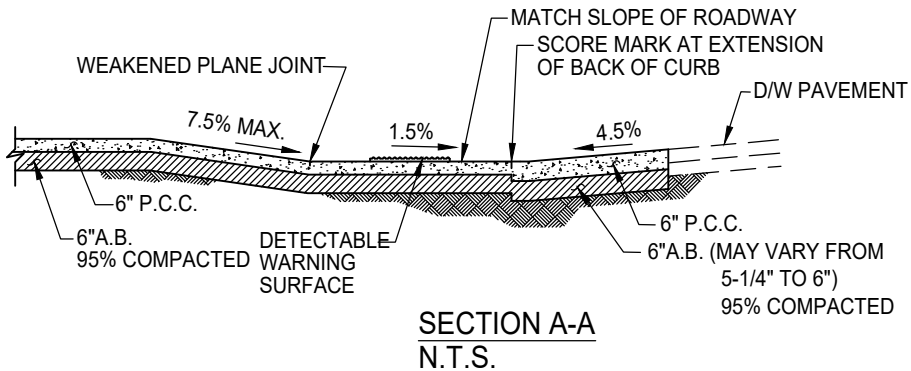
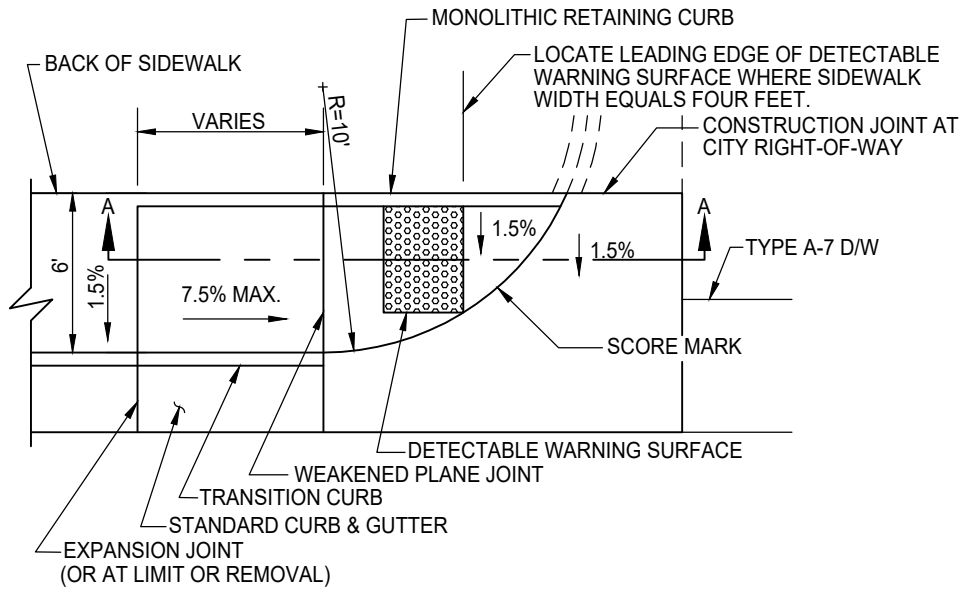

NOTES:

1. IT MAY BE USED FOR RECONSTRUCTION OF TYPE A-7 DRIVEWAYS IN AREAS WITHOUT SUFFICIENT RIGHT-OF-WAY FOR STANDARD TYPE A-7 DRIVEWAY CONSTRUCTION AND WITHOUT WALKWAY EXTENSION ON TO ABUTTING PROPERTY.
2. NO PULL BOX, UTILITY VAULT, UTILITY POLE, MANHOLE OR SIMILAR APPURTENANCE SHALL BE LOCATED WITHIN SIDEWALK RAMP AREA.
3. IT IS DESIRABLE TO LOCATE ALL DRAIN INLETS OUT OF SIDEWALK RAMP AREA. USE OF DRAIN INLET WITHIN RAMP AREA REQUIRES SPECIAL DESIGN OF INLETS.

DATE 09/22/2017		NOT TO SCALE	
REVISION	BY	APPROVED	DATE
01	LM	TW	07/18/2019
02	STN	JRW	02/16/2021

CITY OF ELK GROVE - PUBLIC WORKS

**SIDEWALK RAMP FOR A-7 DRIVEWAYS
WITHOUT ADDITIONAL R/W
(NOT FOR NEW CONSTRUCTION)**

APPROVED BY:
Blair Murdoch 02/26/2021
CITY ENGINEER DATE

DRAWING NUMBER
ST - 21B



MINOR RESIDENTIAL, PRIMARY
RESIDENTIAL, OR COLLECTOR STREET

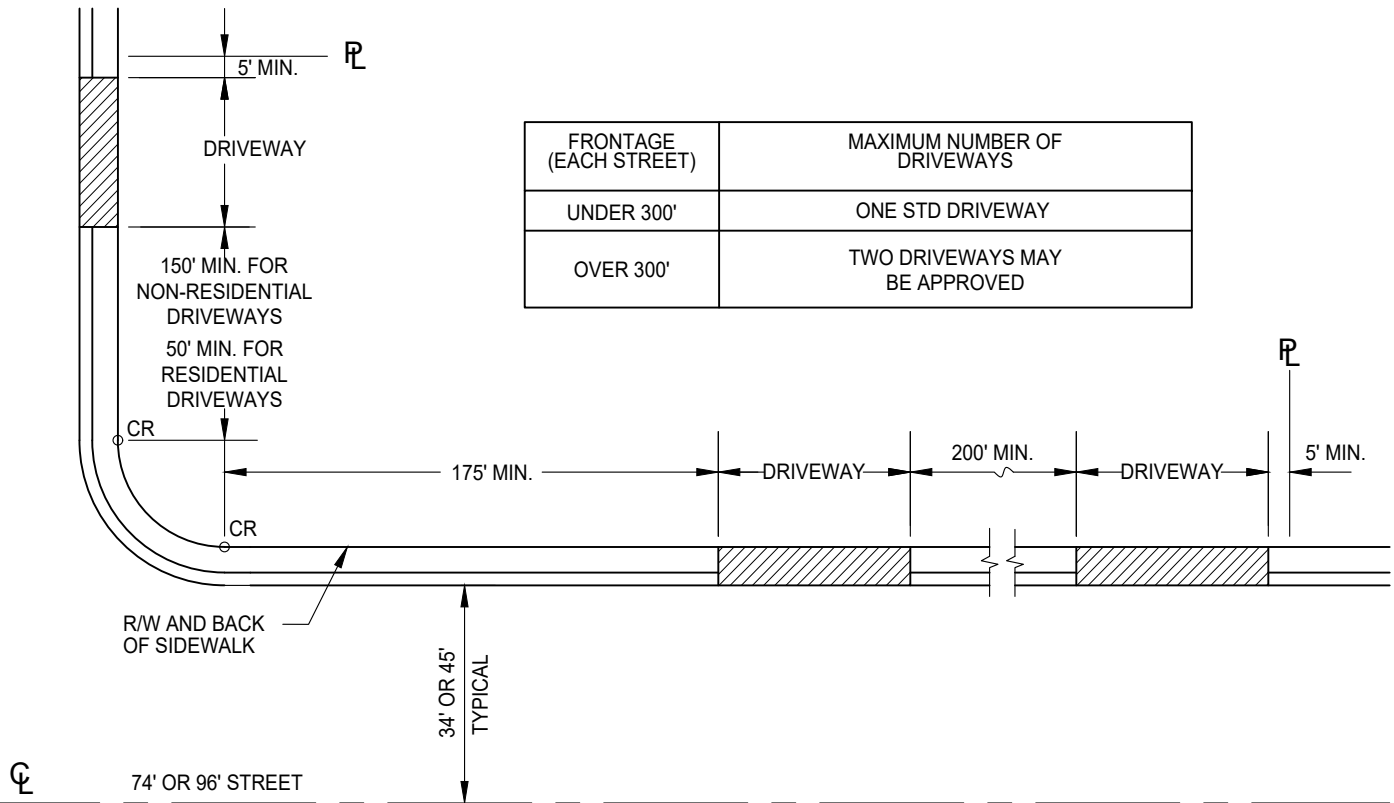

NOTES:

1. DRIVEWAYS ON 74' AND 96' STREETS SHALL HAVE A MINIMUM CLEAR SPACING OF 200' BETWEEN DRIVEWAYS. LESSER SPACING MAY BE APPROVED BY THE DIRECTOR FOR SMALL LOTS WHERE A MINIMUM OF ONE DRIVEWAY PER STREET FRONTAGE WILL BE APPROVED.
2. FOR ADDITIONAL DRIVEWAY REQUIREMENTS SEE SECTION 4-7 OF THE CITY IMPROVEMENT STANDARDS.

DATE: 09/22/2007		NOT TO SCALE	
REVISION	BY	APPROVED	DATE
1	SJB	SMA	03-07-2025

CITY OF ELK GROVE - PUBLIC WORKS

DRIVEWAY LOCATION STANDARDS

APPROVED BY: _____

CITY ENGINEER

03-12-2025

DATE

DRAWING NUMBER

ST - 22



BULB RADIUS REQUIREMENTS	
STREET R/W WIDTH	B/C RADIUS @ BULB
40', 44'	41'

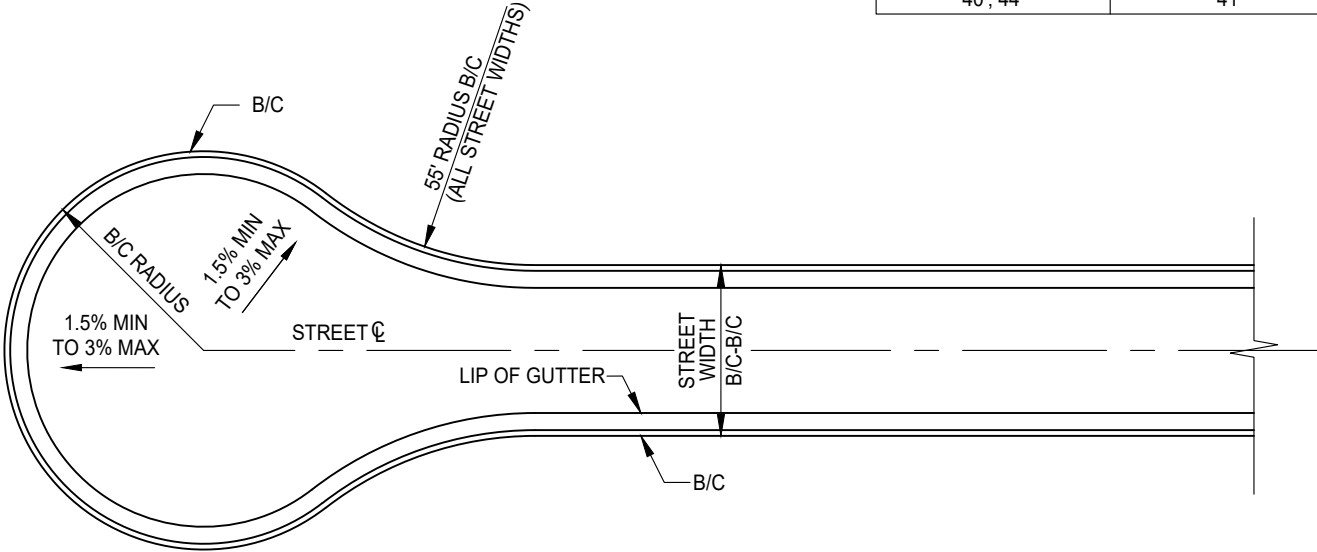

NOTES:

1. A STANDARD W14-1 ("DEAD END") SIGN MAY BE REQUIRED AT THE ENTRANCE TO THE CUL-DE-SAC (SEE SECTION 4-27).
2. NO CUL-DE-SAC SHALL EXCEED 600 FEET IN LENGTH, MEASURED AS THE DISTANCE FROM THE CENTERLINE OF THE INTERSECTING STREET TO THE CENTER OF THE CUL-DE-SAC BULB.

DATE: 03-02-2022		NOT TO SCALE	
REVISION	BY	APPROVED	DATE
1	STN	SA	03-02-2022
2	SJB	SMA	02-23-2024

CITY OF ELK GROVE - PUBLIC WORKS

CUL-DE-SAC

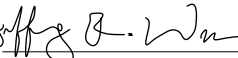
APPROVED BY:

 CITY ENGINEER DATE: 04-19-2024

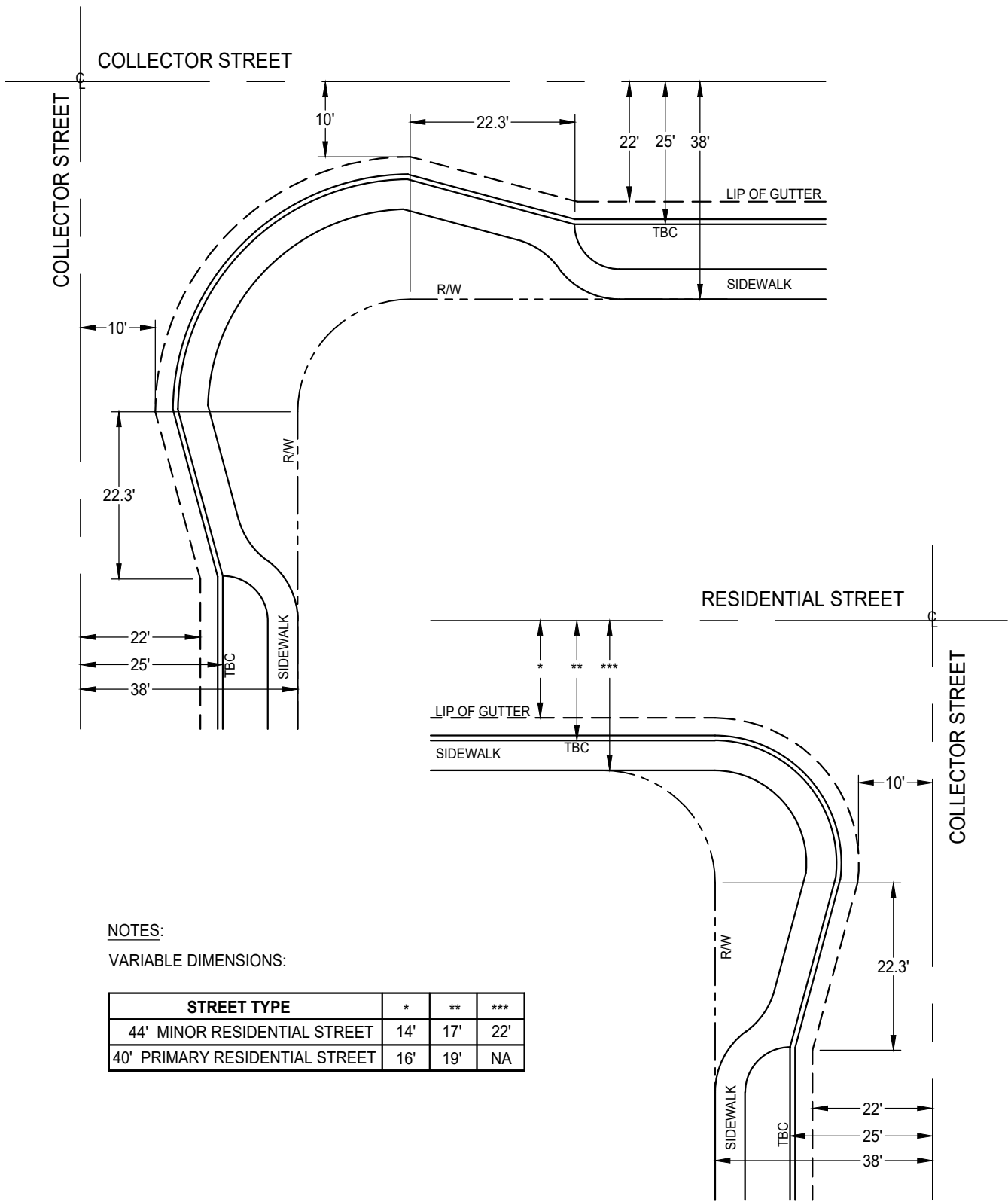

DRAWING NUMBER
ST - 23



NOTES:

VARIABLE DIMENSIONS:

STREET TYPE	*	**	***
44' MINOR RESIDENTIAL STREET	14'	17'	22'
40' PRIMARY RESIDENTIAL STREET	16'	19'	NA

DATE 03-02-2022		NOT TO SCALE	
REVISION	BY	APPROVED	DATE
01	STN	SA	03-02-2022

CITY OF ELK GROVE - PUBLIC WORKS

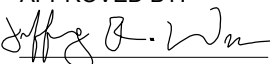
APPROVED BY:

 03-02-2022
 CITY ENGINEER DATE

BULB-OUT DETAIL

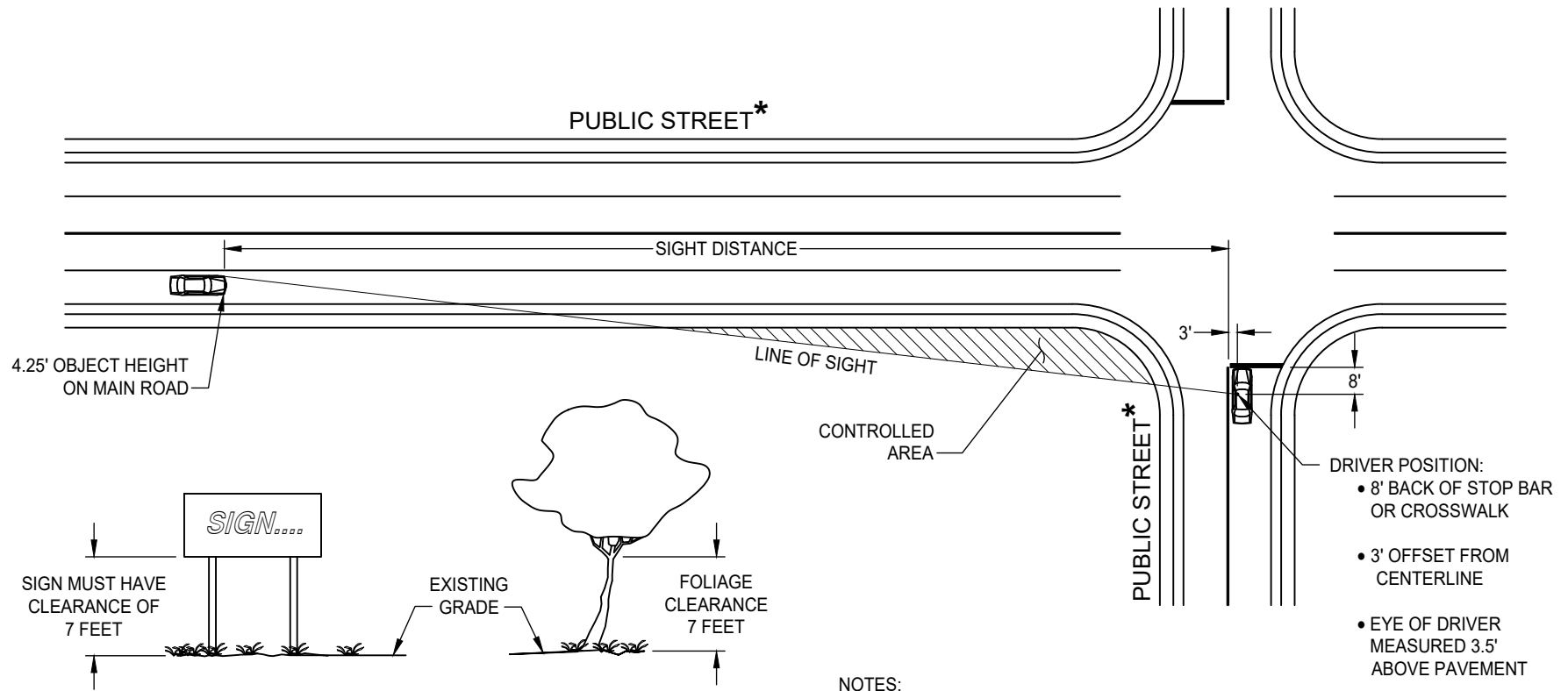

DRAWING NUMBER

ST - 24



NOTES:

1. SHOW LINE OF SIGHT AND SIGHT DISTANCE FOR ALL APPROACHES OF EACH INTERSECTION.
2. SIGHT DISTANCE SHALL COMPLY WITH THE CITY OF ELK GROVE IMPROVEMENT STANDARDS SECTION 4-8.

* FOR STREETS 48 FEET OR WIDER MEASURED FROM BACK OF CURB TO BACK OF CURB, OR AS REQUIRED BY THE DIRECTOR.

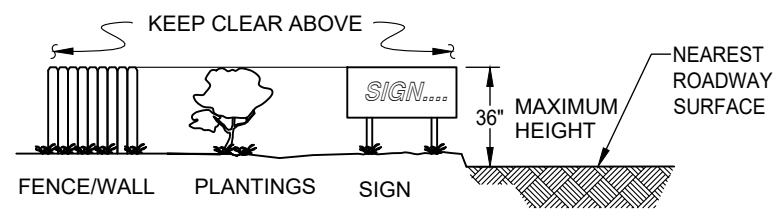

CLEARANCE REQUIRED WITHIN CONTROLLED AREA

NOT TO SCALE			
REVISION	BY	APPROVED	DATE
1	STN	SA	08-17-2021

CITY OF ELK GROVE - PUBLIC WORKS

MINIMUM SIGHT DISTANCE AT INTERSECTIONS AND NON-RESIDENTIAL DRIVEWAYS

APPROVED BY: *Jeffrey B. Wan* 08-18-2021
 CITY ENGINEER DATE

DRAWING NUMBER
ST - 26.1



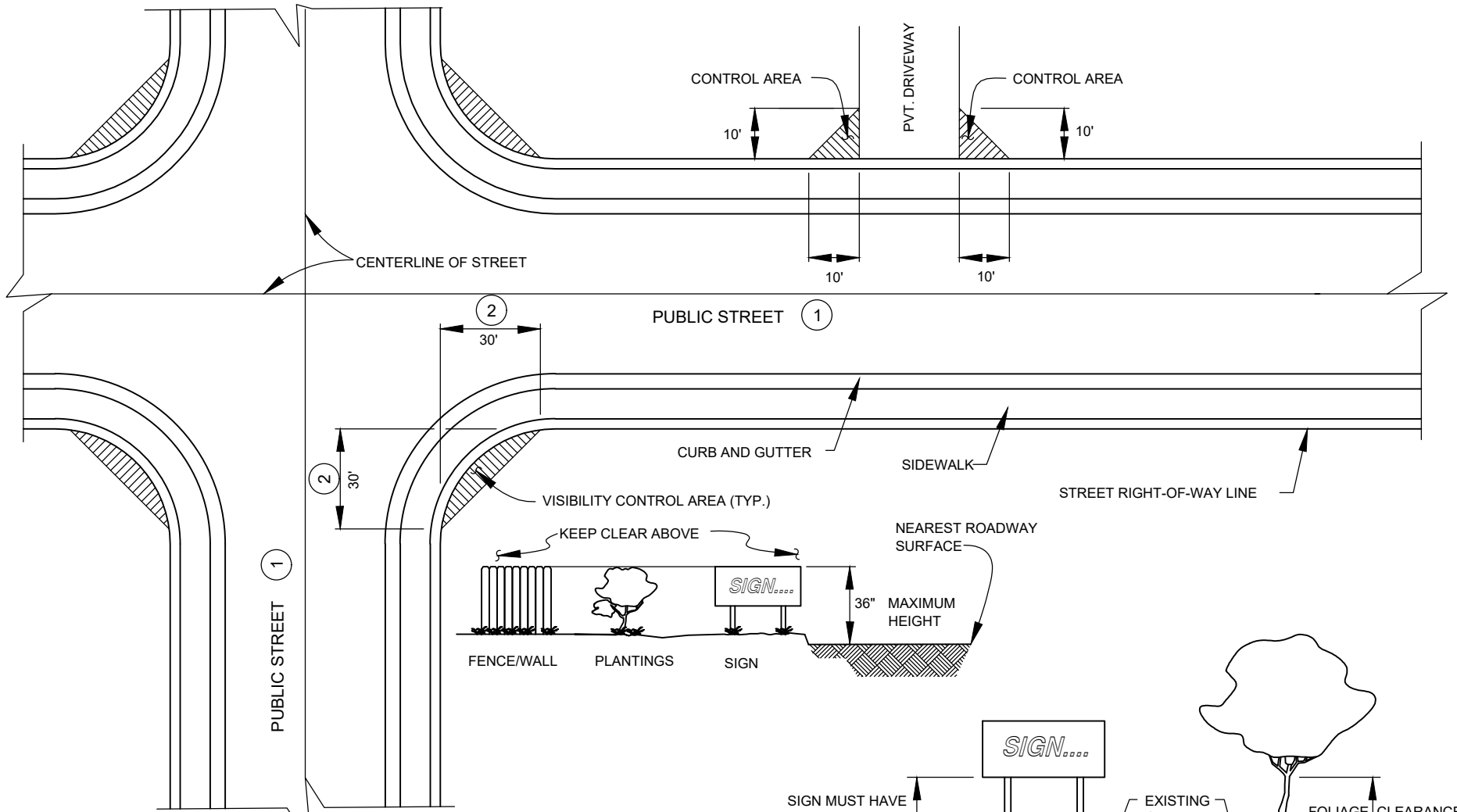

**CLEARANCE REQUIRED
WITHIN CONTROLLED AREA**

- NOTES:**
- ① FOR STREETS LESS THAN 48 FEET MEASURED FROM BACK OF CURB TO BACK OF CURB.
 - ② VISIBILITY CONTROL AREAS MAY BE REDUCED TO A 20' X 20' TRIANGLE AT STOP OR SIGNAL CONTROLLED INTERSECTIONS.

DATE: 09/22/2007		NOT TO SCALE	
REVISION	BY	APPROVED	DATE

CITY OF ELK GROVE - PUBLIC WORKS

**VISIBILITY REQUIREMENTS
CITY OF ELK GROVE**

APPROVED BY:
Paul Murock
CITY ENGINEER

10/24/2018
DATE



DRAWING NUMBER
ST - 26.2

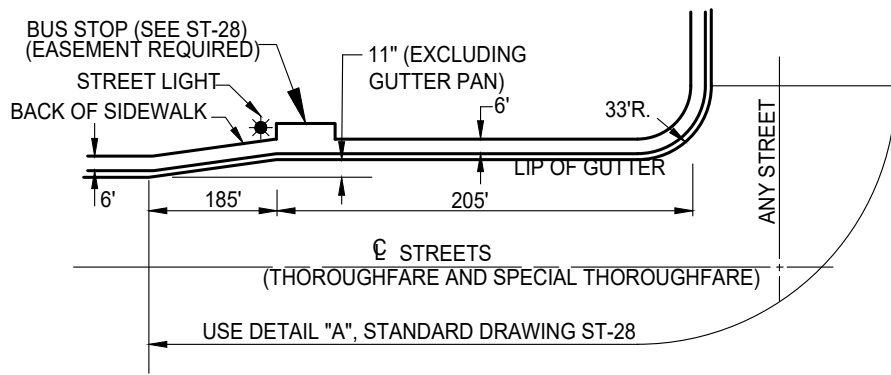

BUS TURNOUT ON THOROUGHFARE STREETS

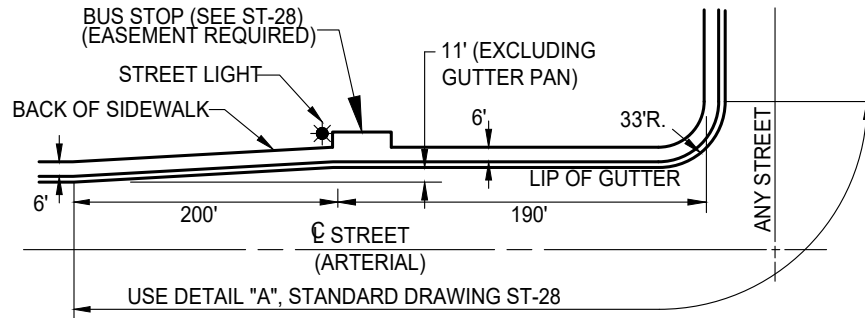

BUS TURNOUT ON ARTERIAL STREETS

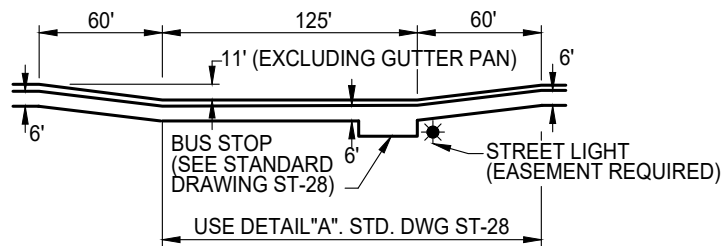

TYPICAL MID-BLOCK BUS TURNOUT

DATE: 09/22/2017		NOT TO SCALE	
REVISION	BY	APPROVED	DATE

CITY OF ELK GROVE - PUBLIC WORKS

APPROVED BY:

 10/24/2018
 CITY ENGINEER DATE

BUS TURNOUTS

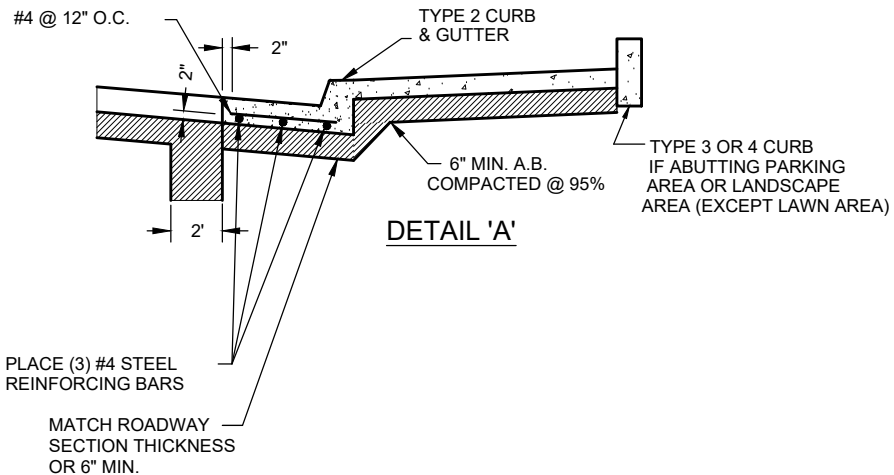
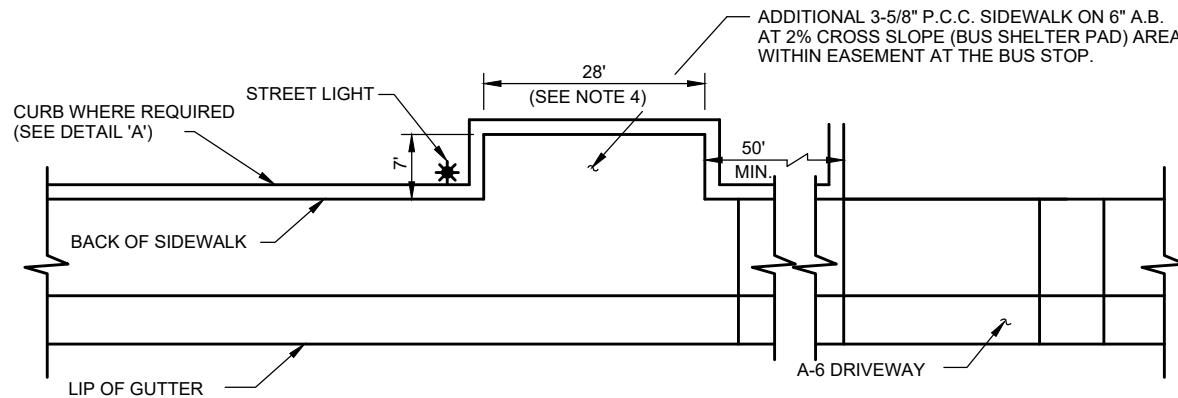

DRAWING NUMBER

ST - 27



NOTES:

1. DETAIL 'A' SECTION SHALL BE USED FOR 100 FEET EACH SIDE OF BUS STOPS WITHOUT TURNOUTS. THE REINFORCING STEEL SHALL BE CONTINUED ACROSS ANY DRIVEWAYS WITHIN THE 100 FOOT DISTANCE FROM THE BUS STOP.
2. SEE STANDARD DRAWING ST-27 FOR APPLICATIONS OF DETAIL 'A' AT BUS STOP TURNOUTS.
3. TRANSITION FROM REINFORCED TYPE 2 CURB TO ABUTTING CURB AND GUTTER SECTION IN 5' BEYOND LIMITS OF BUS STOP AREA AS SHOWN ON DWG. ST-27.
4. PAD LENGTH MAY BE 14' AT MINOR STREET INTERSECTIONS & MID. BLOCK LOCATIONS.

DATE: 09/22/2007		NOT TO SCALE	
REVISION	BY	APPROVED	DATE

CITY OF ELK GROVE - PUBLIC WORKS

APPROVED BY:

Paul Murock

10/24/2018

CITY ENGINEER

DATE

BUS STOP DETAILS



DRAWING NUMBER

ST - 28

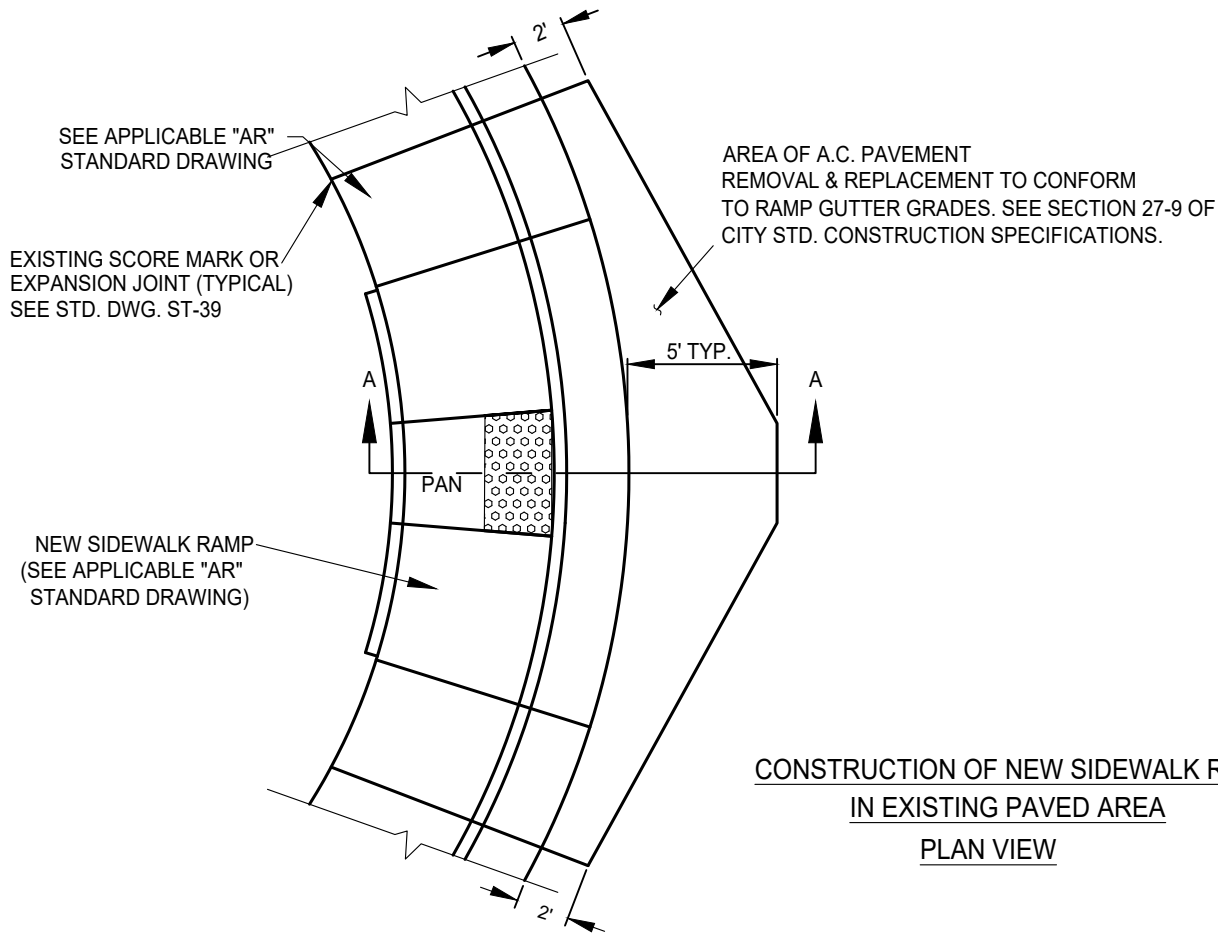

**CONSTRUCTION OF NEW SIDEWALK RAMP
IN EXISTING PAVED AREA
PLAN VIEW**

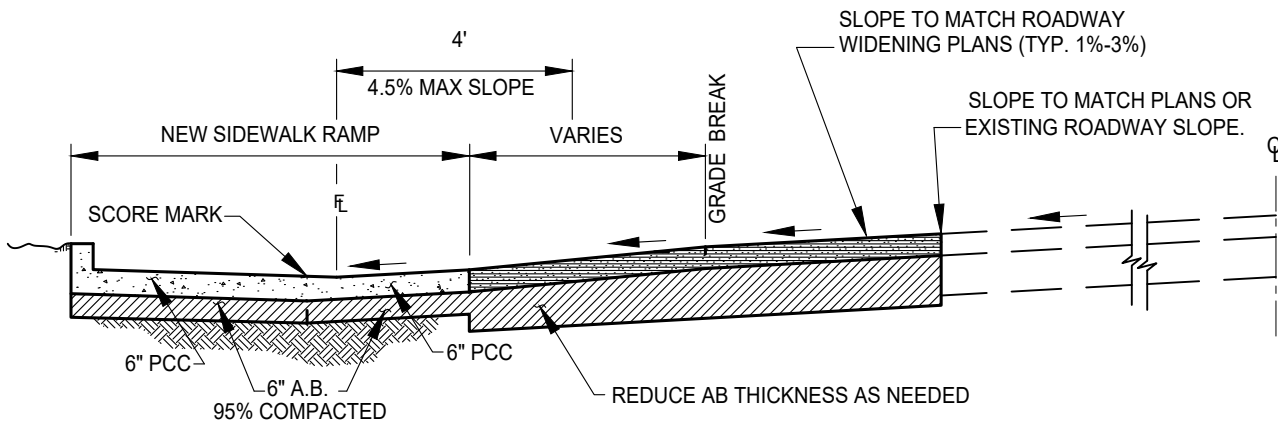

**CONSTRUCTION OF NEW SIDEWALK RAMP
WITH PAVEMENT WIDENING
SECTION A - A**

DATE:		NOT TO SCALE	
REVISION	BY	APPROVED	DATE
1	SJB	SMA	03-27-2024
2	SJB	SMA	06-18-2025

CITY OF ELK GROVE - PUBLIC WORKS

**A.C. CONFORMS TO NEW SIDEWALK
RAMP RE-CONSTRUCTION**

APPROVED BY: _____

06-20-2025
DATE

CITY ENGINEER

DRAWING NUMBER
ST - 30



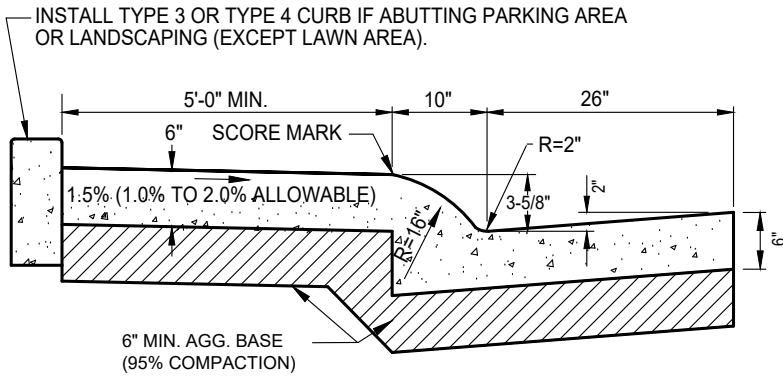

TYPE 1A & TYPICAL SIDEWALK

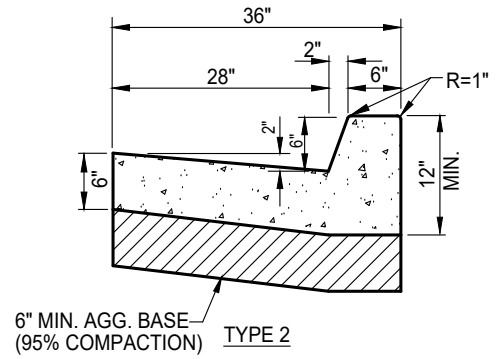

6" MIN. AGG. BASE (95% COMPACTION) TYPE 2

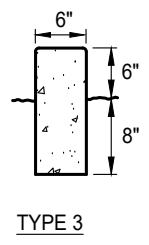

TYPE 3

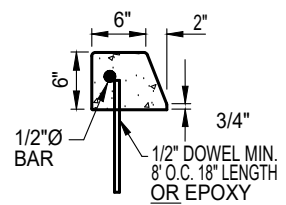

TYPE 4 & 4A
(4A REQUIRES BOTH DOWELS AND EPOXY)

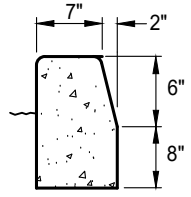

TYPE 5

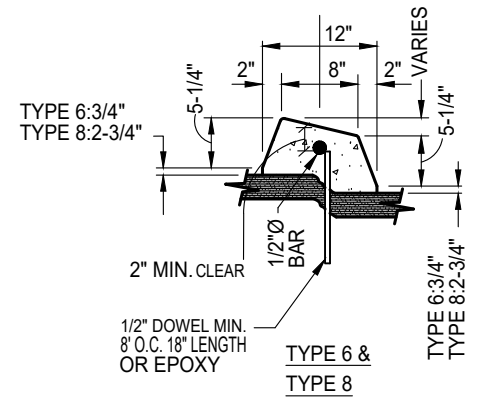

TYPE 6: 3/4"
TYPE 8: 2-3/4"
TYPE 6 & TYPE 8

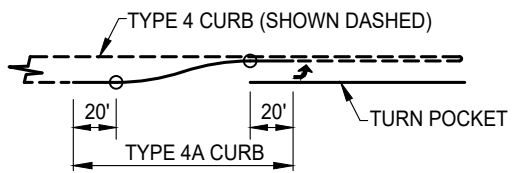

PLAN FOR TYPICAL PLACEMENT OF TYPE 4A CURB

NOTES:

1. SEE SECTION 27-3.01 FOR REQUIREMENT FOR EXPANSION JOINTS, WEAKENED PLANE JOINTS AND SCORE MARKS.
2. 1/2" RADIUS ON EXPOSED EDGES UNLESS NOTED OTHERWISE.
3. SEE ST-28 FOR BUS STOP DETAIL A 1/2-INCH CONCRETE BATTER SHALL BE PLACED ON ALL CURB LIPS.

DATE: 09/22/2007		NOT TO SCALE	
REVISION	BY	APPROVED	DATE

CITY OF ELK GROVE - PUBLIC WORKS

TYPICAL CURB & GUTTER SECTIONS

APPROVED BY:
Paul Muddock
CITY ENGINEER
10/24/2018
DATE



DRAWING NUMBER
ST - 31

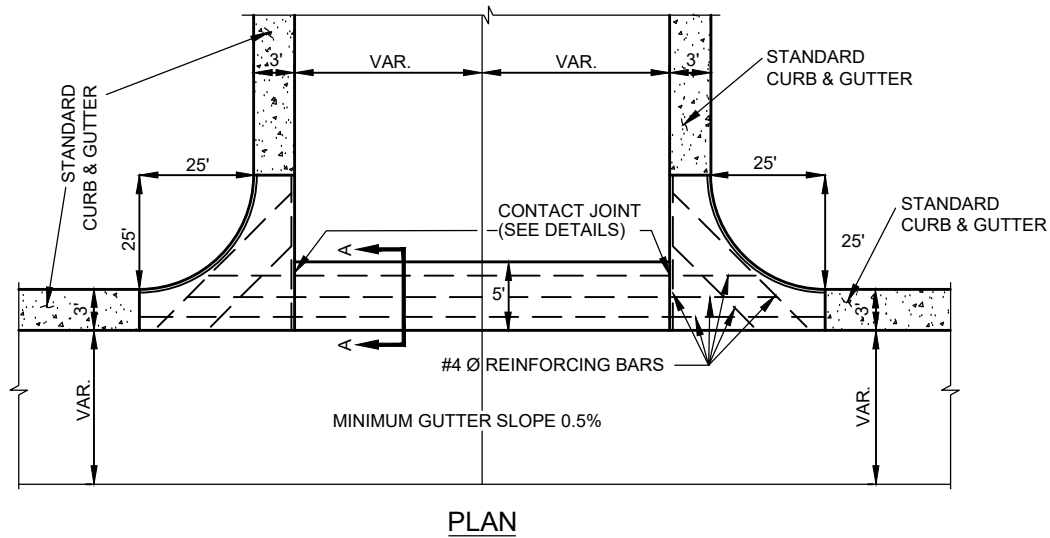
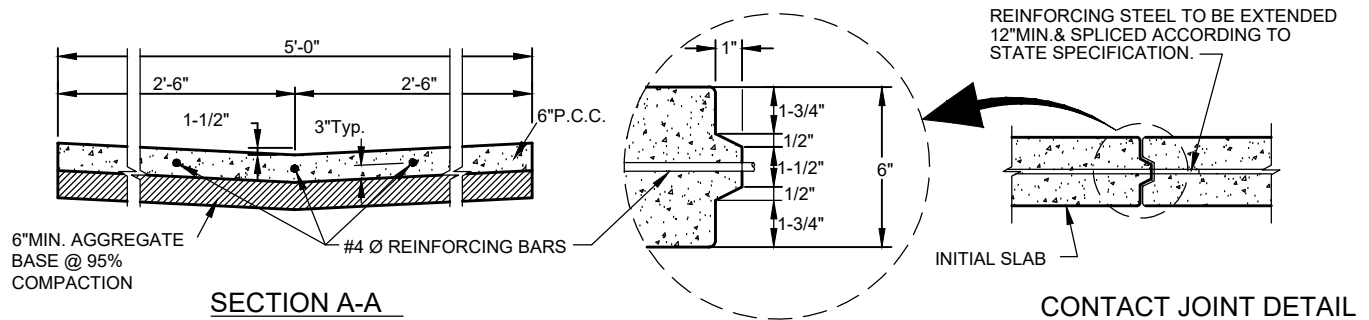

NOTE:

1. 6" MIN AGGREGATE BASE (95% RELATIVE COMPACTION) TO BE PLACED WITHIN LIMITS OF CROSS GUTTER.

DATE 09/22/2007		NOT TO SCALE	
REVISION	BY	APPROVED	DATE
01	STN	JRW	02/16/2021

CITY OF ELK GROVE - PUBLIC WORKS

APPROVED BY:

Paul M. ...

02/26/2021

CITY ENGINEER

DATE

CROSS GUTTER



DRAWING NUMBER

ST - 32

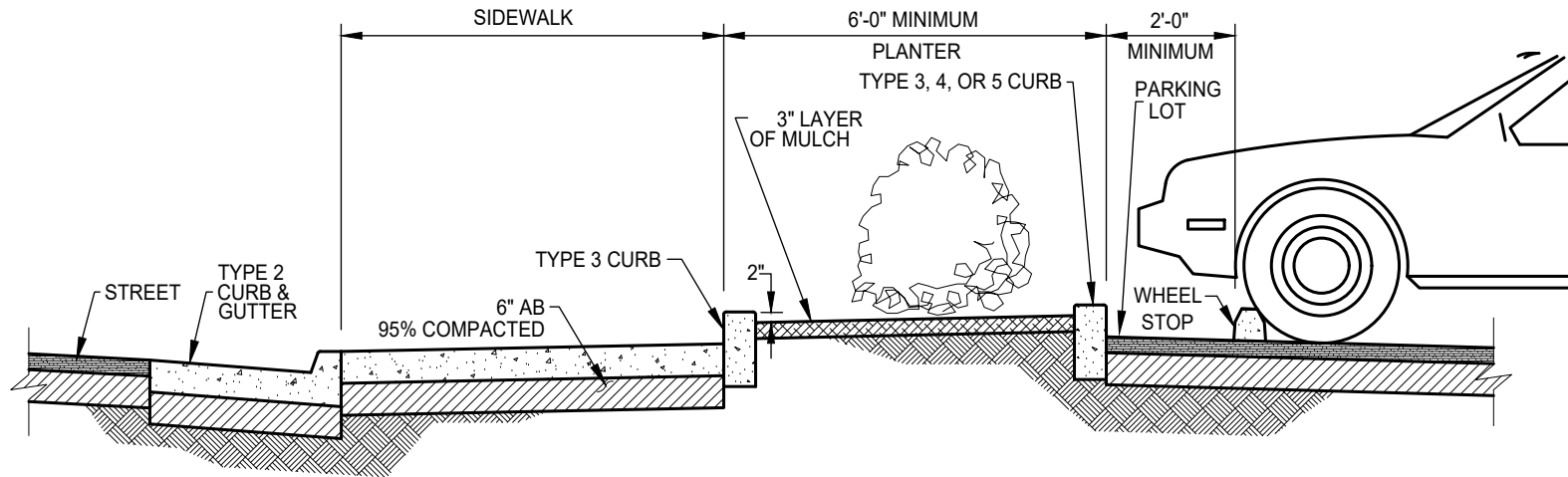

NOTES:

1. FOR 74', 96', & 118' STREET WIDTHS AND COMMERCIAL DEVELOPMENT.
2. SEE SECTION 4-16 OF THE CITY IMPROVEMENT STANDARDS FOR REQUIREMENTS.
3. TYPE 3 CURB AT THE BACK OF SIDEWALK MAY BE OMITTED IF LAWN IS PLANTED TO THE BACK OF SIDEWALK.
4. SIDEWALKS SHALL BE SEPARATED ON ALL 74', 96', & 118' STREETS

DATE: 09/22/2007		NOT TO SCALE	
REVISION	BY	APPROVED	DATE
1	SJB	SMA	03-28-2024

CITY OF ELK GROVE - PUBLIC WORKS

BARRIER CURB DETAIL

APPROVED BY: _____

CITY ENGINEER _____ DATE _____

DRAWING NUMBER

ST - 33



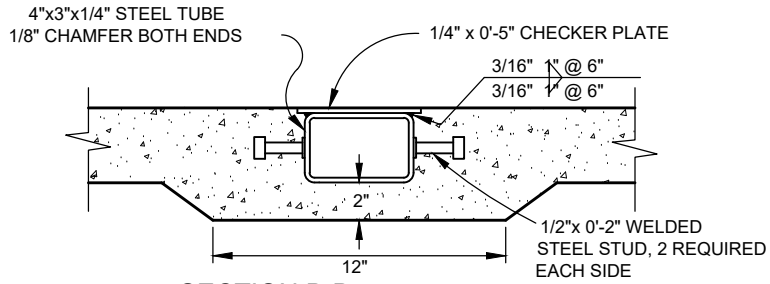

SECTION B-B

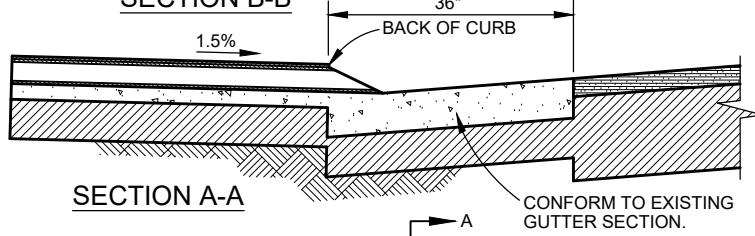

SECTION A-A

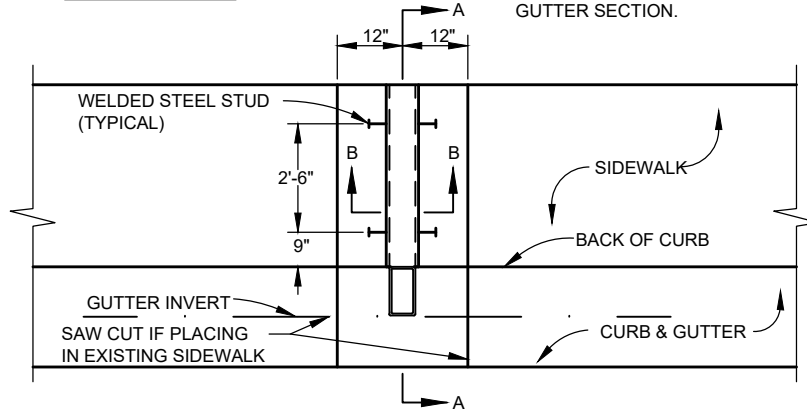

PLAN VIEW OF CURB, GUTTER & SIDEWALK

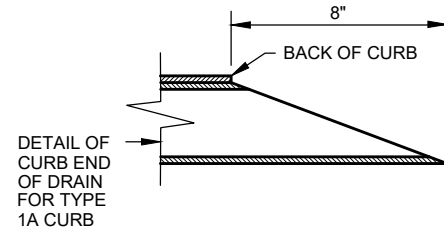
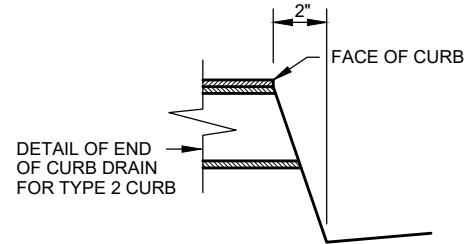

NOTE:

1. GALVANIZE AFTER FABRICATION

DATE: 09/22/2007		NOT TO SCALE	
REVISION	BY	APPROVED	DATE

CITY OF ELK GROVE - PUBLIC WORKS

APPROVED BY:

Paul Murock

10/24/2018

CITY ENGINEER

DATE

**UNDER
SIDEWALK DRAIN**



DRAWING NUMBER

ST - 34

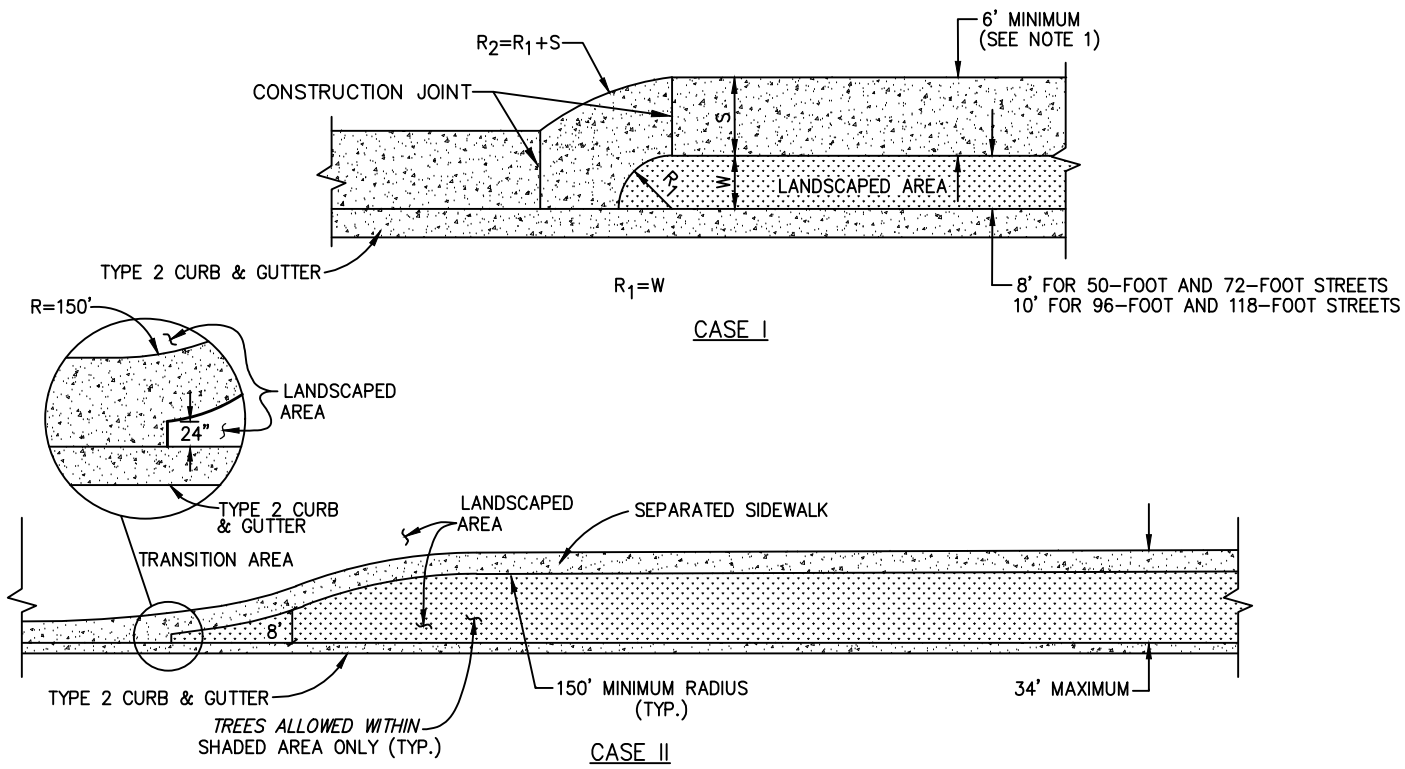

NOTES:

1. ON THOROUGHFARES, ARTERIALS, AND WHERE 6 FOOT SIDEWALKS ARE REQUIRED BY THE IMPROVEMENT STANDARDS. 5 FOOT MINIMUM ALL OTHER LOCATIONS.
2. CROSS SLOPE OF SEPARATED SIDEWALK TO BE 1.5% (1.0% TO 2.0% ALLOWABLE). LONGITUDINAL GRADE NOT TO EXCEED 5%.
3. USE OF SEPARATED SIDEWALKS WILL REQUIRE STREET LIGHTING REVIEW IN RELATION TO LANDSCAPE PLAN, AND MAY REQUIRE ADDITIONAL SIDEWALK LIGHTING.
4. COMPACTION UNDER SEPARATED SIDEWALK AREA AT 90%, UNDER ATTACHED AREA AT 95%.

DATE: 09/22/2007		NOT TO SCALE	
REVISION	BY	APPROVED	DATE

CITY OF ELK GROVE - PUBLIC WORKS

**SEPARATED (OR DETACHED)
SIDEWALK TRANSITION**

APPROVED BY:

Paul Murock

CITY ENGINEER

10/24/2018

DATE



DRAWING NUMBER

ST - 35

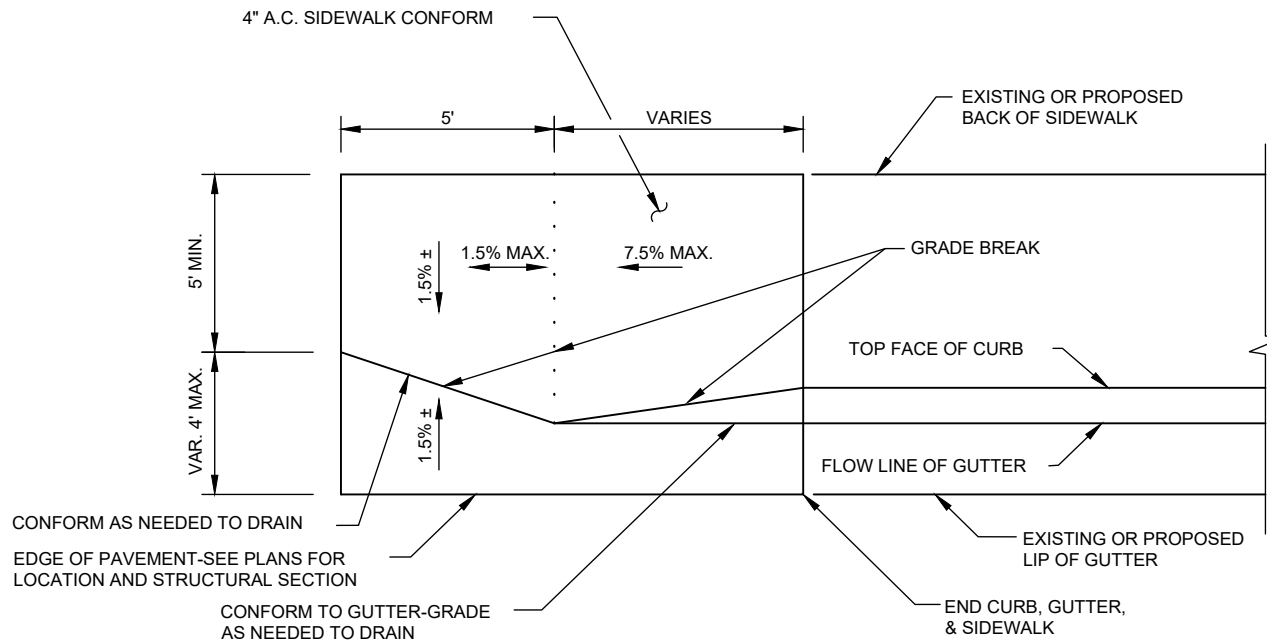

NOTE:

1. A SIDEWALK BARRICADE SHALL BE REQUIRED IF THE END OF THE A.C. SIDEWALK CONFORM ABUTS A DRAINAGE DITCH OR ANY OTHER SURFACE THAT WOULD POSE A HAZARD TO PEDESTRIANS.

DATE: 09/22/2007		NOT TO SCALE	
REVISION	BY	APPROVED	DATE
1	SJB	SMA	03-28-2024

CITY OF ELK GROVE - PUBLIC WORKS

**A.C. SIDEWALK
CONFORM**

APPROVED BY:

[Signature] 05-28-2024

CITY ENGINEER

DATE



DRAWING NUMBER

ST - 36

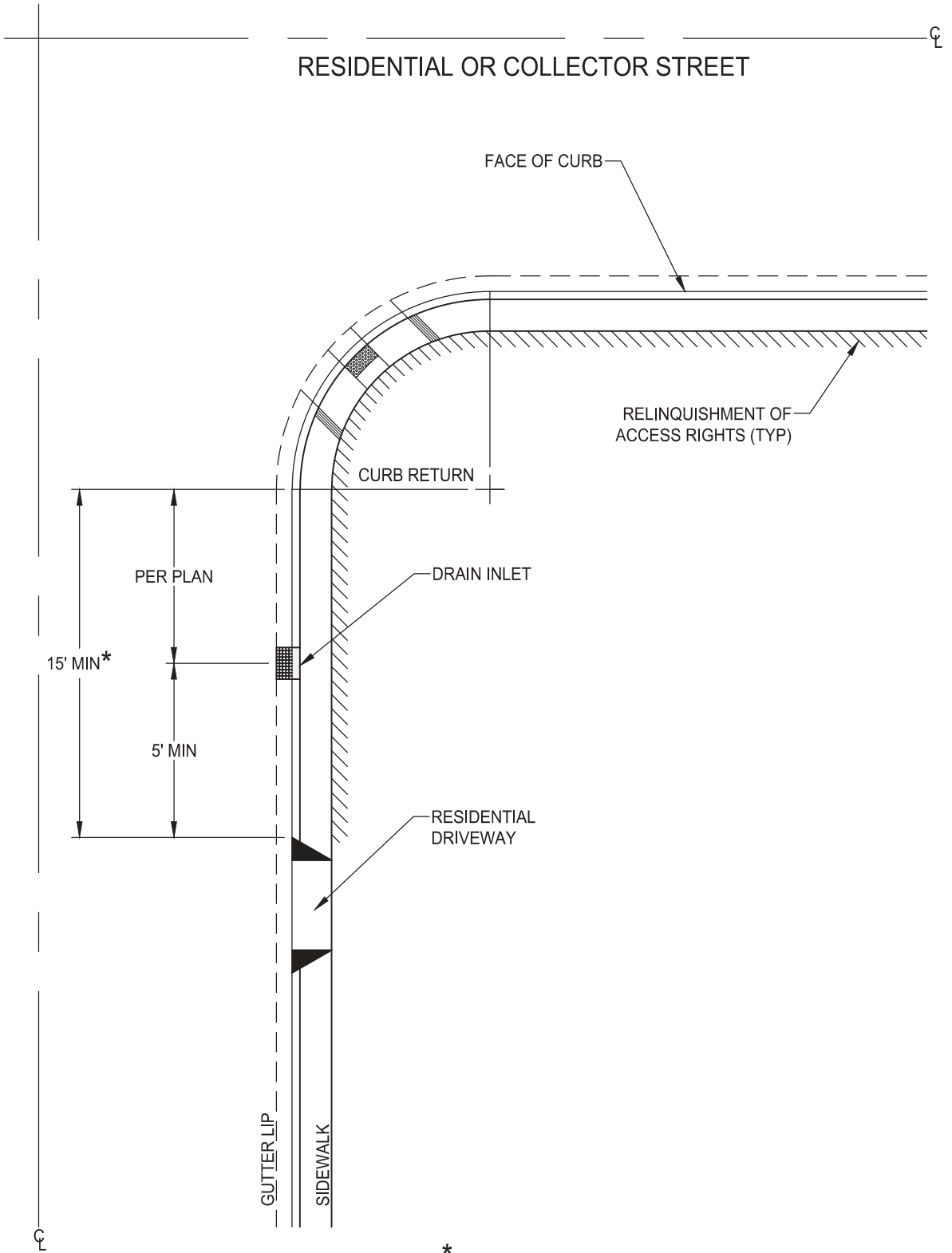

* THE 15' DIMENSION MAY BE REDUCED AS DETERMINED BY THE DIRECTOR WHERE LOTS ARE LESS THAN 56' WIDE.

DATE: 09/22/2017		NOT TO SCALE	
REVISION	BY	APPROVED	DATE

CITY OF ELK GROVE - PUBLIC WORKS

**RESIDENTIAL CORNER LOT DRIVEWAY
LOCATION**

RESIDENTIAL OR COLLECTOR STREETS

APPROVED BY:
Paul Muddoch
CITY ENGINEER

10/24/2018
DATE

DRAWING NUMBER
ST - 37



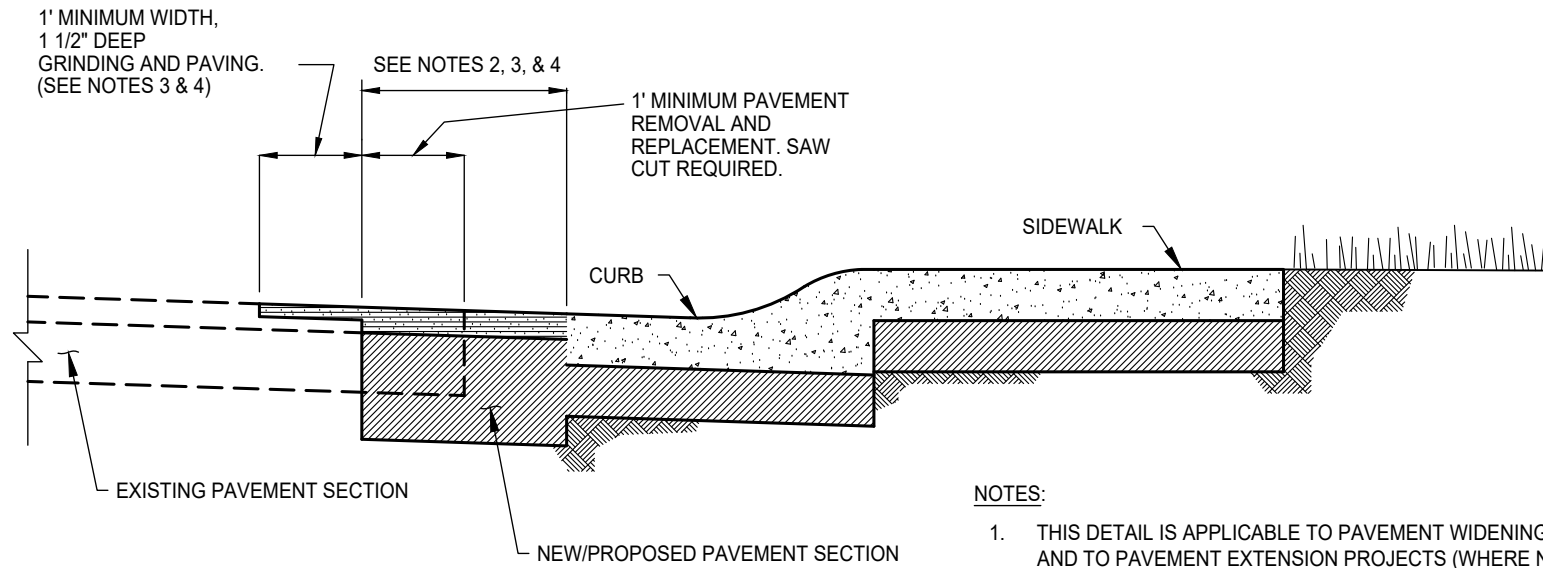

NOTES:

1. THIS DETAIL IS APPLICABLE TO PAVEMENT WIDENING PROJECTS AND TO PAVEMENT EXTENSION PROJECTS (WHERE NEW ROAD CONNECTS TO EXISTING PAVEMENT).
2. 2' MINIMUM DISTANCE EXCEPT WHEN INSIDE A BIKE LANE. DISTANCE SHALL BE FROM LIP OF CURB TO FULL EXTENT OF THE BIKE LANE.
3. GRINDING AND PAVING JOINT SHALL BE LOCATED ALONG GUTTER PATH, LANE PATH, OR CENTER OF LANES AND SHALL NOT BE PLACED IN WHEEL PATH.
4. ADDITIONAL GRINDING AND PAVING MAY BE REQUIRED IF WITHIN TWO (2) FEET OF A SURFACE CRACK OR A LOCATION UNSUITABLE TO PAVE AGAINST AT THE INSPECTOR'S DISCRETION, AT THE CONTRACTOR'S EXPENSE.

DATE: 09/22/2007		NOT TO SCALE	
REVISION	BY	APPROVED	DATE
1	SJB	SMA	02-23-2024

CITY OF ELK GROVE - PUBLIC WORKS

PAVEMENT WIDENING DETAIL

APPROVED BY: *Jeffrey J. Wan* 03-12-2024
CITY ENGINEER DATE

DRAWING NUMBER
ST - 38



EXPANSION JOINT
FILLER MATERIAL
(MATCH FULL
CONCRETE SECTION)

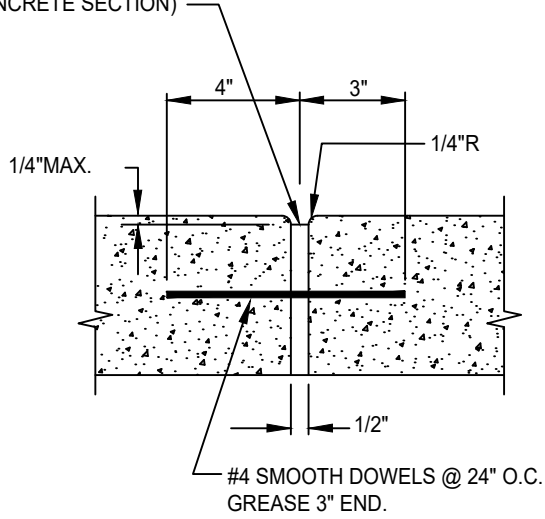

EXPANSION JOINT

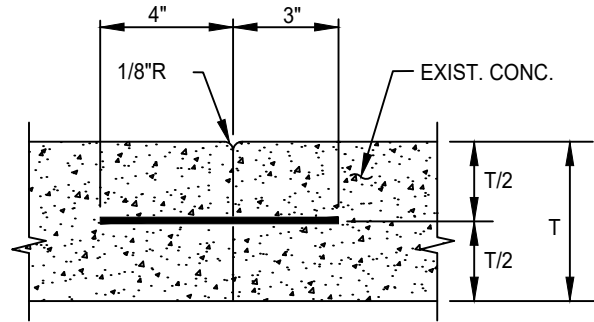

#4 DOWELS @ 24" O.C.
(DRILL HOLE AND SET DOWEL IN GROUT)

SIDEWALK CONTACT JOINT

(USE WHERE NEW CONSTRUCTION OF S/W AND OR
CURB & GUTTER ABUTS EXISTING IMPROVEMENTS.)

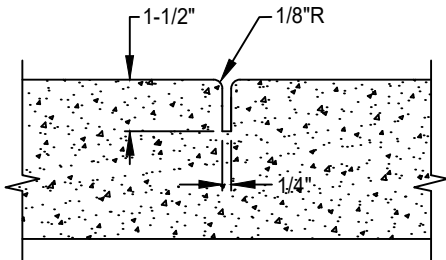

WEAKENED PLANE JOINT

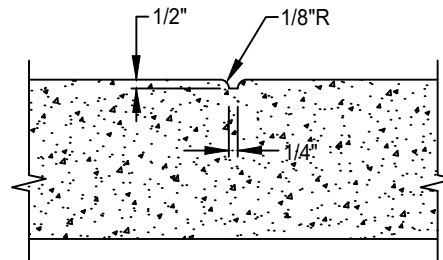

SCORE MARK

NOTE:

1. JOINT SPACING PER SECTION
27-3.01 OF THE CITY STANDARD
CONSTRUCTION SPECIFICATIONS.

DATE: 09/22/2017		NOT TO SCALE	
REVISION	BY	APPROVED	DATE

CITY OF ELK GROVE - PUBLIC WORKS

**STANDARD CONCRETE
JOINT DETAILS**

APPROVED BY:

Paul Muroch

10/24/2018

CITY ENGINEER

DATE



DRAWING NUMBER

ST - 39

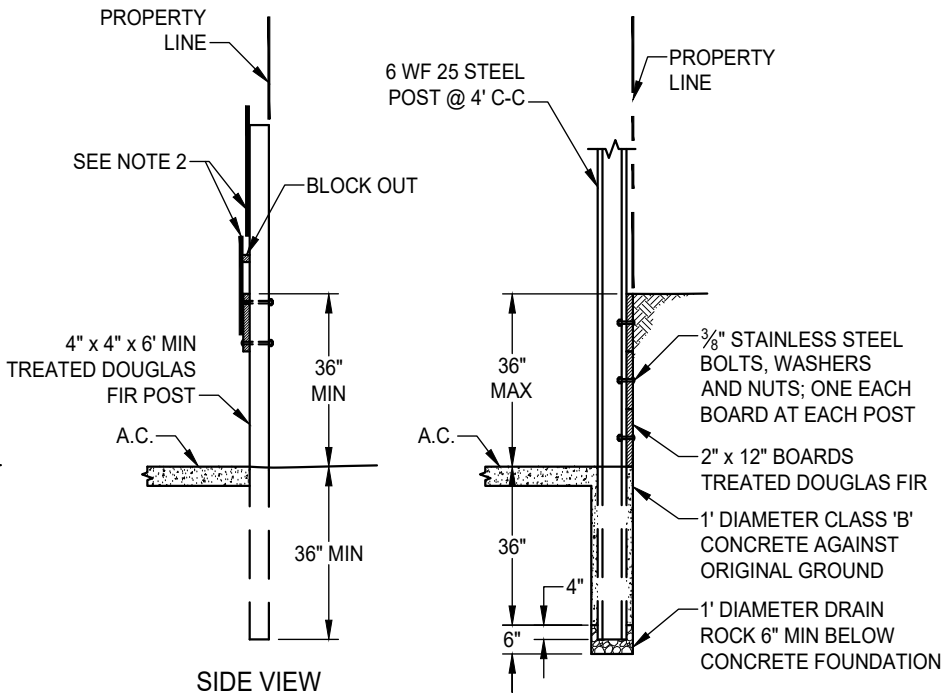
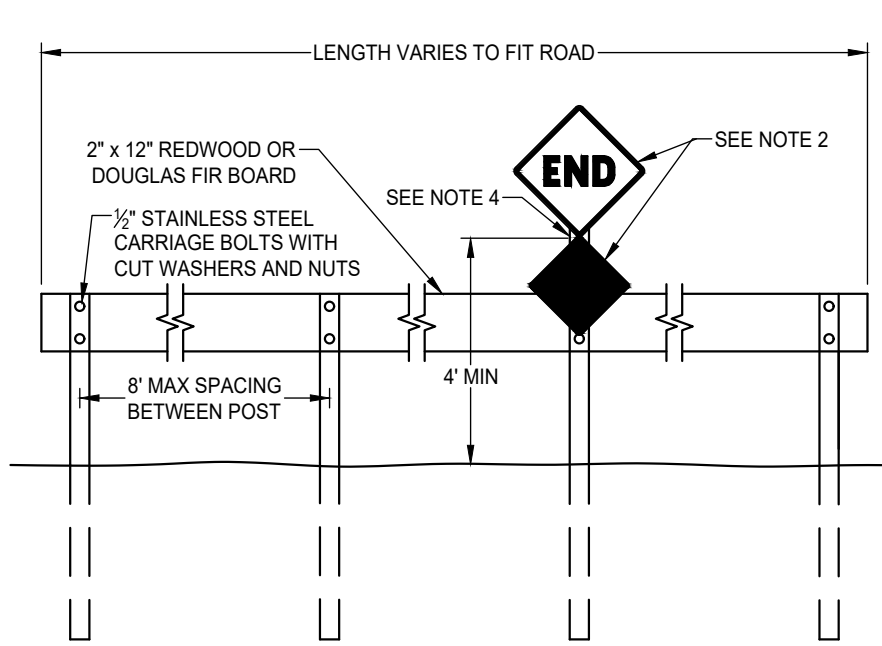

NOTES:

1. WHERE PERMISSION HAS BEEN GRANTED TO CLOSE AN EXISTING PUBLIC STREET, A R11-2 "ROAD CLOSED" SIGN WILL BE REQUIRED ON THE CENTERLINE OF THE ROAD IN ADDITION TO THE W31(CA) "END" SIGN.
2. 24" x 24" W31(CA) SIGN AND 18" x 18" OM4-3 MARKER. BLOCK OUT AS NECESSARY FOR OM4-3 MARKER TOP MOUNTING BOLT (BOTTOM MOUNTING BOLT NORMALLY THROUGH BARRIER RAIL). OM4-3 MARKER TO HAVE SOLID RED REFLECTIVE BACKGROUND WITHOUT ADDED REFLECTORS.
3. ALL EXPOSED SURFACES OF BARRICADE SHALL BE PAINTED WITH TWO (2) COATS OF WHITE PAINT CONFORMING TO STATE OF CALIFORNIA STANDARD SPECIFICATIONS SECTION 91-3.
4. POST AT CENTER OR NEAREST TO CENTER ON RIGHT HAND SIDE TO BE EXTENDED TO PROVIDE MOUNTING FOR SIGNS.
5. POST SHALL BE PRESSURE TREATED PER STATE OF CALIFORNIA STANDARD SPECIFICATIONS SECTION 57-2.01.

STREET ENDING IN CUT WHERE SLOPE IS NOT OBTAINABLE

RIGHT OF WAY WIDTH	W31 (CA)		OM4-3		R11-2	
	SIZE	NO.	SIZE	NO.	SIZE	NO.
40', 42'	24"	1	18"	1	36" x 24"	1
50', 56', 60'	24"	1	18"	1	48" x 30"	1
66', 70', 74'	24"	1	18"	1	48" x 30"	1
80', 84'	24"	2	18"	2	48" x 30"	1
108', 130'	24"	3	18"	3	48" x 30"	1

DATE: 09/22/2007		NOT TO SCALE	
REVISION	BY	APPROVED	DATE

CITY OF ELK GROVE - PUBLIC WORKS

STREET CLOSURE TIMBER BARRICADE

APPROVED BY:
Paul M. Muelich
CITY ENGINEER

10/24/2018
DATE

DRAWING NUMBER
ST - 41



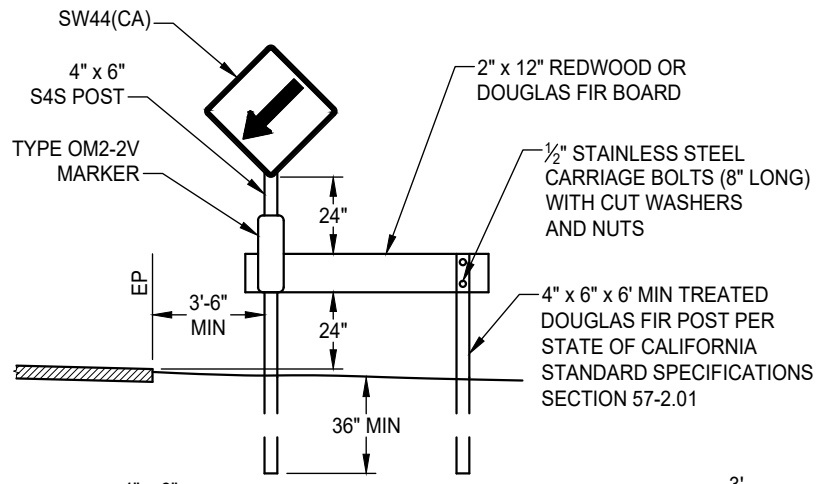
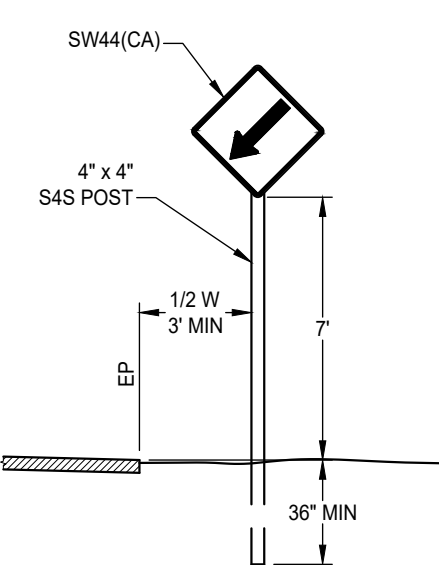

NOTE:
 1. ALL EXPOSED SURFACES OF BARRICADE SHALL BE PAINTED WITH TWO (2) COATS OF WHITE PAINT CONFORMING TO STATE OF CALIFORNIA STANDARD SPECIFICATIONS SECTION 91-3.

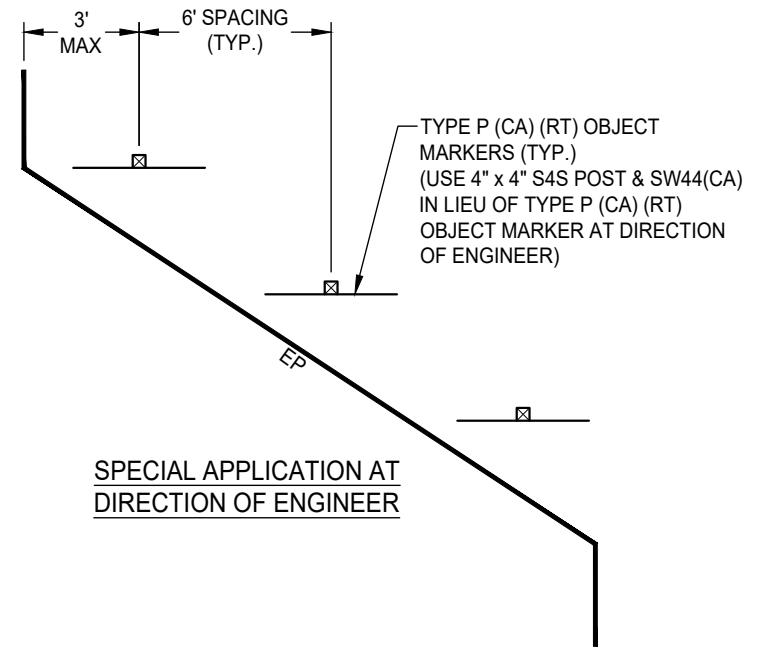
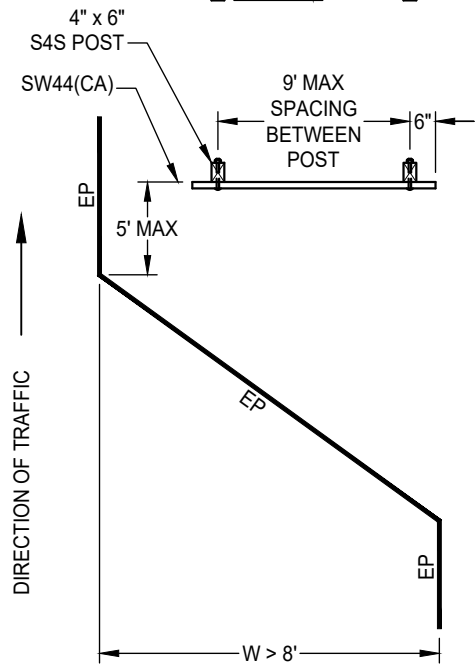
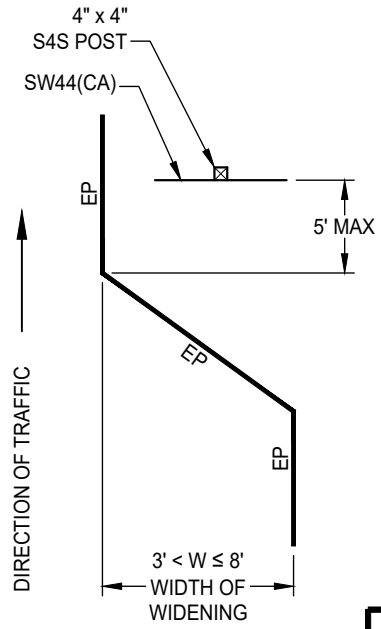

SPECIAL APPLICATION AT DIRECTION OF ENGINEER

DATE: 09/22/2007		NOT TO SCALE	
REVISION	BY	APPROVED	DATE
1	SJB	SMA	07-12-2024

CITY OF ELK GROVE - PUBLIC WORKS

SIGNS AND BARRICADES AT ABRUPT CHANGE OF PAVEMENT WIDTH

APPROVED BY:

 CITY ENGINEER

12-18-2024
 DATE

DRAWING NUMBER
ST - 42

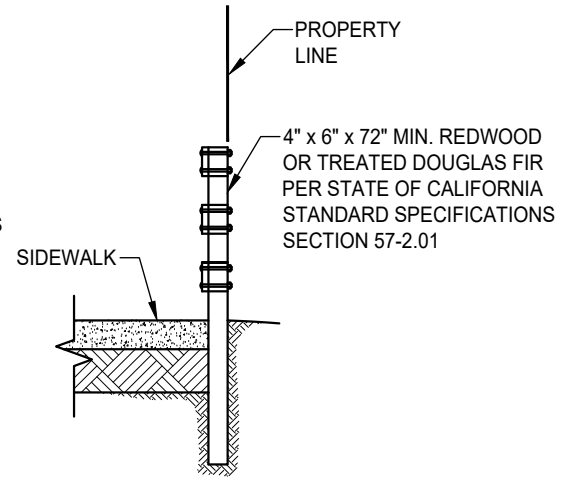
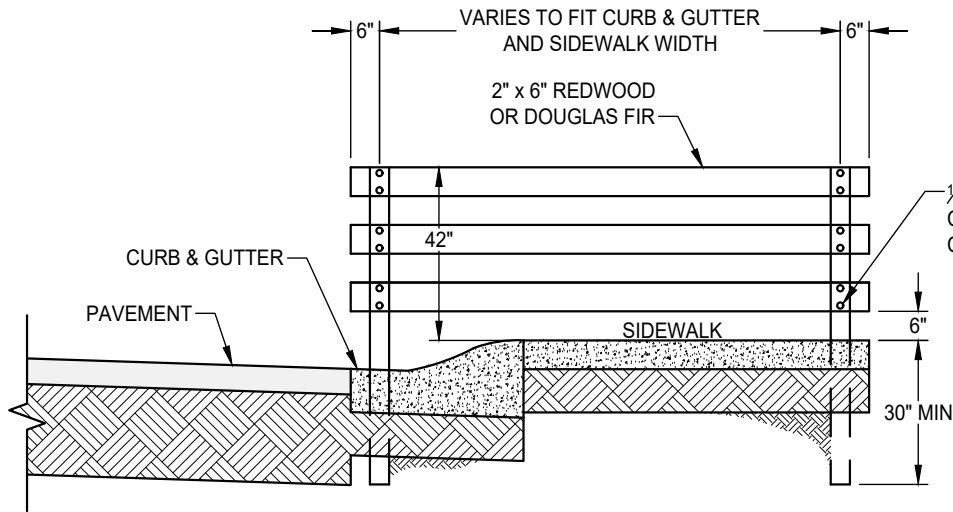



SIDE VIEW

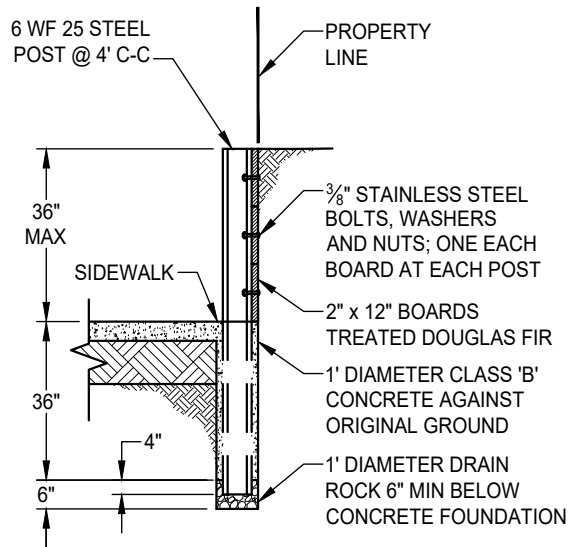

DETAIL FOR SIDEWALK BARRICADE WITH RETAINING WALL

NOTES:

1. SIDEWALK BARRICADES TO BE ERECTED AT EACH LOCATION WHERE SATISFACTORY PROVISION CAN NOT BE MADE FOR PEDESTRIAN TO CONTINUE BEYOND THE TERMINUS OF A SIDEWALK AND A HAZARD IS PRESENT.
2. ALL EXPOSED SURFACES OF BARRICADES SHALL BE PAINTED WITH TWO (2) COATS OF WHITE PAINT CONFORMING TO STATE OF CALIFORNIA STANDARD SPECIFICATIONS SECTION 91-3.

DATE: 09/22/2007		NOT TO SCALE	
REVISION	BY	APPROVED	DATE
1	SJB	SMA	03-28-2024

CITY OF ELK GROVE - PUBLIC WORKS

SIDEWALK BARRICADE

APPROVED BY:

[Signature] 05-28-2024

CITY ENGINEER

DATE



DRAWING NUMBER

ST - 43

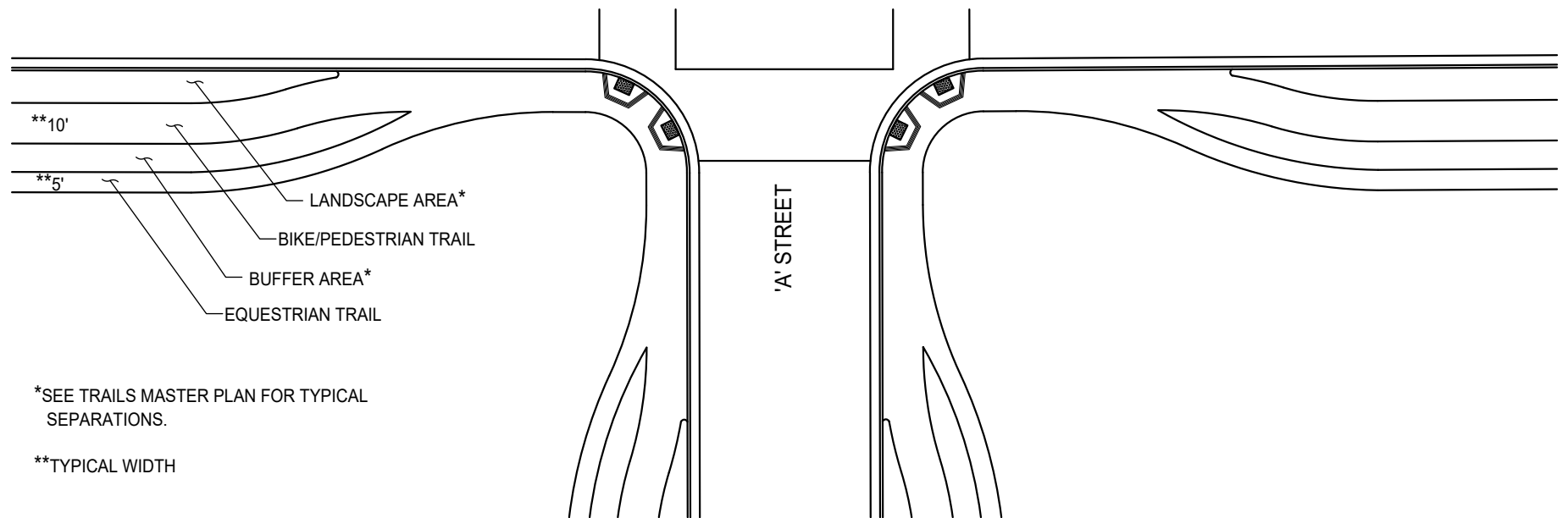
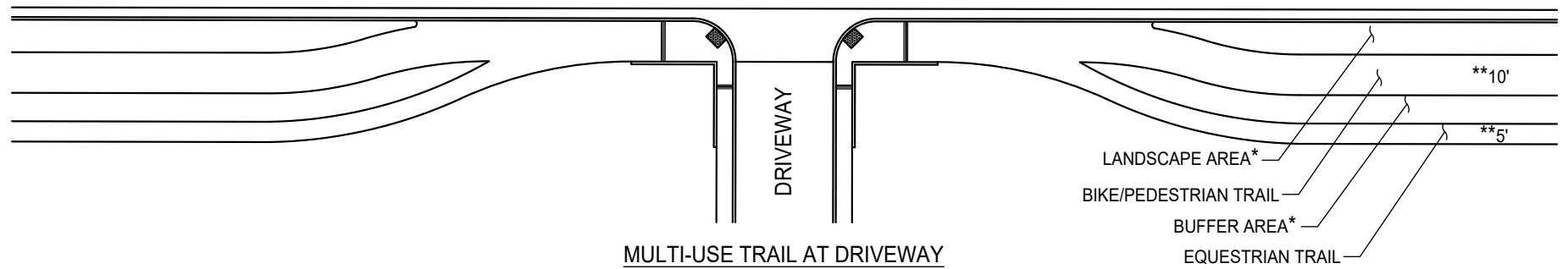

*SEE TRAILS MASTER PLAN FOR TYPICAL SEPARATIONS.

**TYPICAL WIDTH

DATE: 09/22/2007		NOT TO SCALE	
REVISION	BY	APPROVED	DATE
1	SJB	SMA	03-28-2024

CITY OF ELK GROVE - PUBLIC WORKS

**MULTI-USE TRAIL
CONNECTIONS AT DRIVEWAYS AND
INTERSECTIONS**

APPROVED BY: _____

05-28-2024
DATE

CITY ENGINEER

DRAWING NUMBER

ST - 44



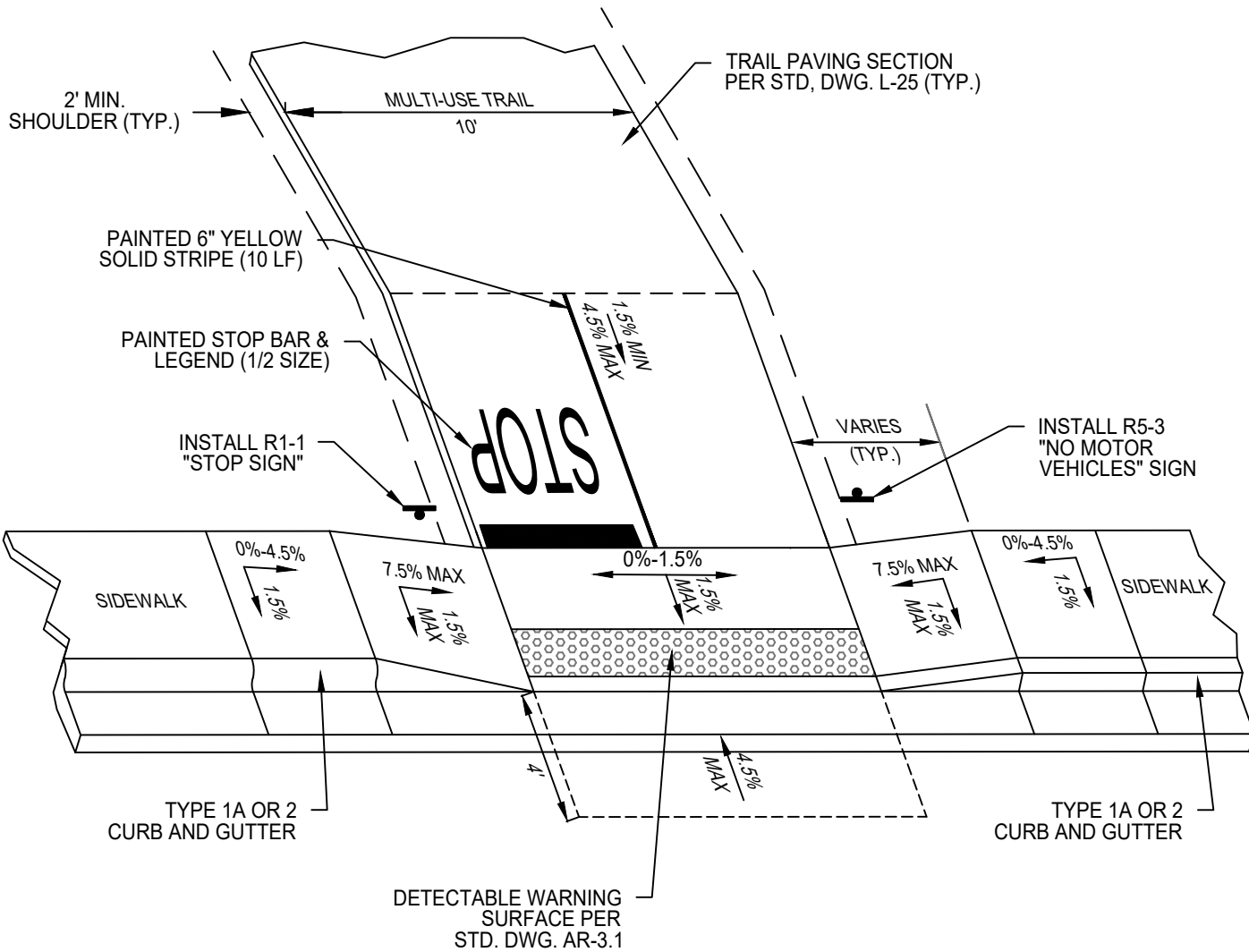

NOTES:

1. TRAIL CONNECTION MUST BE AT A CROSSWALK.
2. MID-BLOCK CROSSWALK SIGNAGE, STRIPING AND/OR SIGNAL TO BE INSTALLED AS DETERMINED BY THE CITY.

DATE 03-02-2022		NOT TO SCALE	
REVISION	BY	APPROVED	DATE
1	SJB	SMA	05-01-2025

CITY OF ELK GROVE - PUBLIC WORKS

**MULTI-USE TRAIL CONNECTION
AT MID-BLOCK CROSSWALK**

APPROVED BY: _____
CITY ENGINEER DATE
05-28-2025

DRAWING NUMBER
ST-45



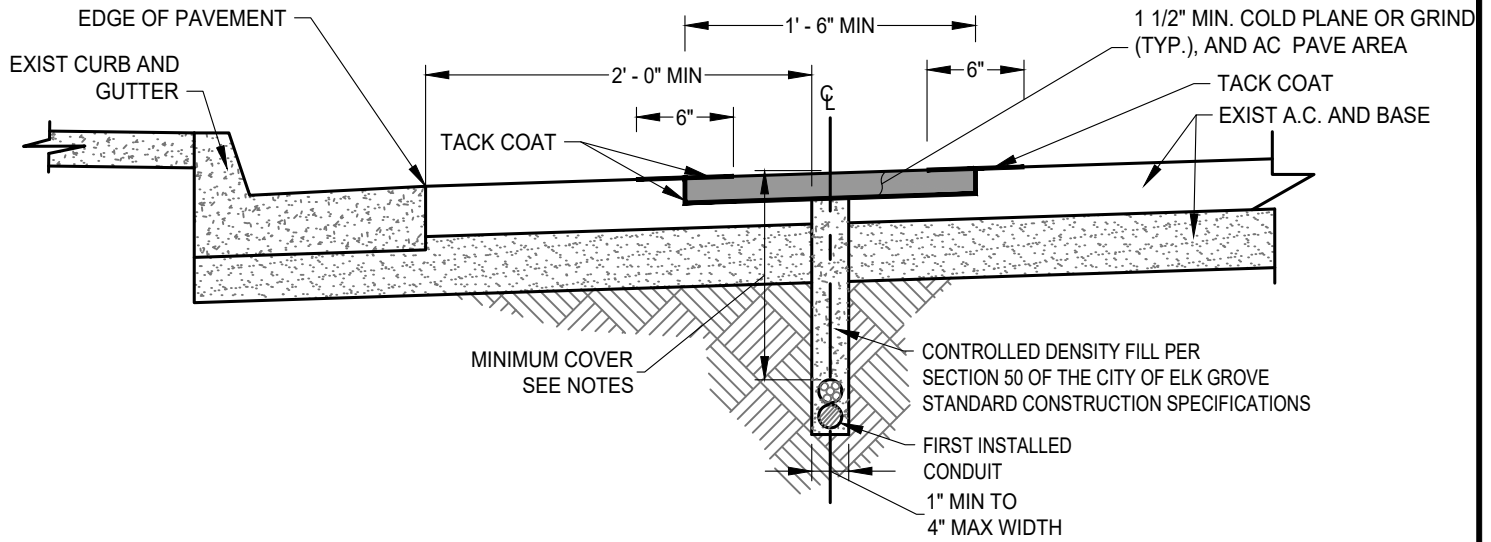

MICRO-TRENCH SECTION, TYPICAL
NOT TO SCALE

NOTES:

1. MINIMUM COVER

STREET TYPE	DEPTH
RESIDENTIAL AND COLLECTOR	1' - 3"
ARTERIAL AND THOROUGHFARE	1' - 6"
2. ALL CONDUITS MUST BE ANCHORED OR SECURED TO THE BOTTOM OF THE TRENCH TO MAINTAIN MINIMUM COVER.
3. SAND BACKFILL SHALL NOT BE ALLOWED WITHIN THE MINIMUM COVER LIMITS.

GENERAL:

1. MICRO-TRENCHING SHALL ONLY BE USED TO INSTALL FIBER OPTIC CABLE.
2. MICRO-TRENCHING SHALL NOT BE ALLOWED IN CONCRETE PAVED AREAS.
3. MICRO-TRENCH SHALL BE CONSTRUCTED WITH CONTINUOUS STRAIGHT AND NEAT EDGES.
4. MICRO-TRENCH ALIGNMENTS SHALL CONSIST OF RUNS PARALLEL TO THE CENTERLINE OF THE STREET.
5. STREET CROSSINGS SHALL BE PERPENDICULAR TO THE STREET CENTERLINE. THE CAPPING LIMITS ON TRENCHES PERPENDICULAR TO THE STREET CENTERLINE SHALL BE A MINIMUM OF 3 FEET IN WIDTH.
6. ALL MICRO-TRENCHES SHALL BE COMPLETELY BACKFILLED TO FINISH GRADE BY THE END OF THE WORK DAY.
7. COMMENCEMENT OF SURFACE PREPARATION SUCH AS GRINDING FOR ASPHALT CONCRETE PAVING REPLACEMENT WILL OCCUR NO SOONER THAN 48 HOURS AFTER BACKFILL OF TRENCH. FIELD CONDITIONS MAY NECESSITATE A LONGER WAIT AS DETERMINED BY THE ENGINEER.
8. AS SOON AS BACKFILL HAS CURED, NOT TO EXCEED 30 CALENDAR DAYS, ASPHALT CONCRETE SHALL BE GROUND AND CAPPED AS FOLLOWS:
 - A. WHERE ANGULAR CROSSING OR ANY LENGTH-WISE CUTS OF A BIKE LANE OCCUR BY MICRO-TRENCHING, THE CAPPING LIMITS SHALL EXTEND THE FULL WIDTH OF THE BIKE LANE. PERPENDICULAR CROSSINGS MAY RECEIVE TYPICAL CAPPING WIDTH PER NOTE ABOVE. PAVEMENT MARKINGS SHALL BE RESTORED IN KIND.
 - B. EXISTING AC AND BACKFILL SHALL BE GROUND DOWN 1½-INCHES, FOR A WIDTH OF 18-INCHES BUT NO LESS THAN 6-INCHES FROM BOTH EDGES OF THE MICRO-TRENCH AND RESURFACED WITH CONCRETE ASPHALT. WHEN THE CAP LIMIT IS WITHIN 2-FEET OR LESS FROM THE GUTTER FACE, CURB, SLAB OR STRUCTURE, THE CAP LIMIT SHALL EXTEND TO THAT ITEM.
 - C. TACK COAT ALL EDGES WITH SS-1H EMULSIFIED.
9. CONNECTION TO SERVICE LATERALS, JUNCTION BOXES, ETC., SHALL BE DONE SUCH THAT CURB AND GUTTER IS NOT DISTURBED, SETTLED OR DAMAGED. REMOVAL LIMITS OF SIDEWALK SHALL FOLLOW APPLICABLE STANDARDS AND REQUIREMENTS AS APPROVED BY THE ENGINEER.
10. THE USE OF HYDRO-JETTING IS NOT PERMITTED. TRENCHLESS METHODS SHALL NOT CREATE A VOID TWO TIMES GREATER THAN CONDUIT. VOID SHALL BE COMPACTED AND BACKFILLED WITH CONTROLLED DENSITY FILL PER SECTION 50 OF THE CITY OF ELK GROVE STANDARD CONSTRUCTION SPECIFICATIONS.

DATE 01-30-2023	NOT TO SCALE	CITY OF ELK GROVE - PUBLIC WORKS	APPROVED BY: 01-30-2023 CITY ENGINEER DATE
REVISION	BY	MICRO-TRENCHING	DRAWING NUMBER ST-46

**SINGLE SIDEWALK RAMP
WITHOUT CROSSWALK STRIPING**

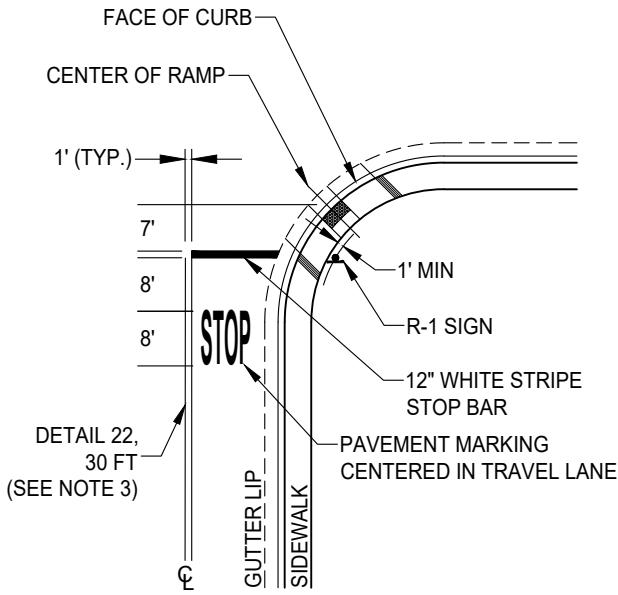

**DUAL SIDEWALK RAMPS
WITHOUT CROSSWALK STRIPING**

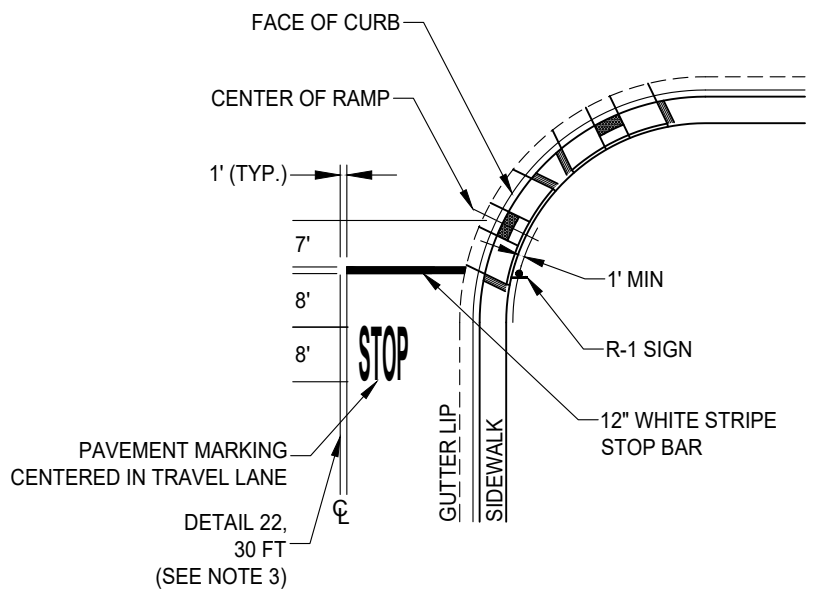

LADDER DETAIL

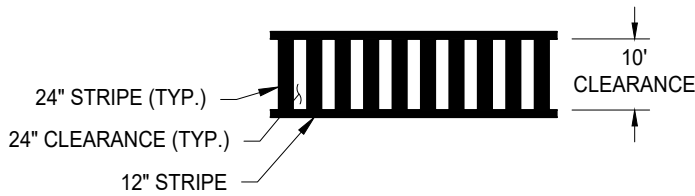

NOTES:

1. STOP SIGN SHALL BE 30" FOR STREET WITH POSTED SPEED LIMIT OF 35 M.P.H. OR LESS AND 36" IF THE POSTED SPEED LIMIT IS 40 M.P.H. OR GREATER.
2. STOP SIGN SHALL BE SUPPLEMENTED WITH R1-3 (3-WAY OR 4-WAY) SIGNS WHERE APPROPRIATE.
3. STRIPING DETAILS SHALL BE PER STATE PLANS, WITH DETAIL 22 REQUIRED ON ROADWAYS WIDER THAN 36FT.
4. CROSSWALK STRIPE SHALL BE EITHER YELLOW OR WHITE AS DIRECTED BY THE ENGINEER OR DETAILED ON THE PLANS, CROSSWALKS WITHIN 500FT OF A SCHOOL SHALL BE LADDER TYPE (SEE LADDER DETAIL) AND PAINTED YELLOW.
5. DETAILS ABOVE "DUAL SIDEWALK RAMPS WITHOUT CROSSWALK STRIPING" AND "TYPICAL SIDEWALK RAMPS WITH CROSSWALK STRIPING" ALLOWS FOR ON STREET PARKING.

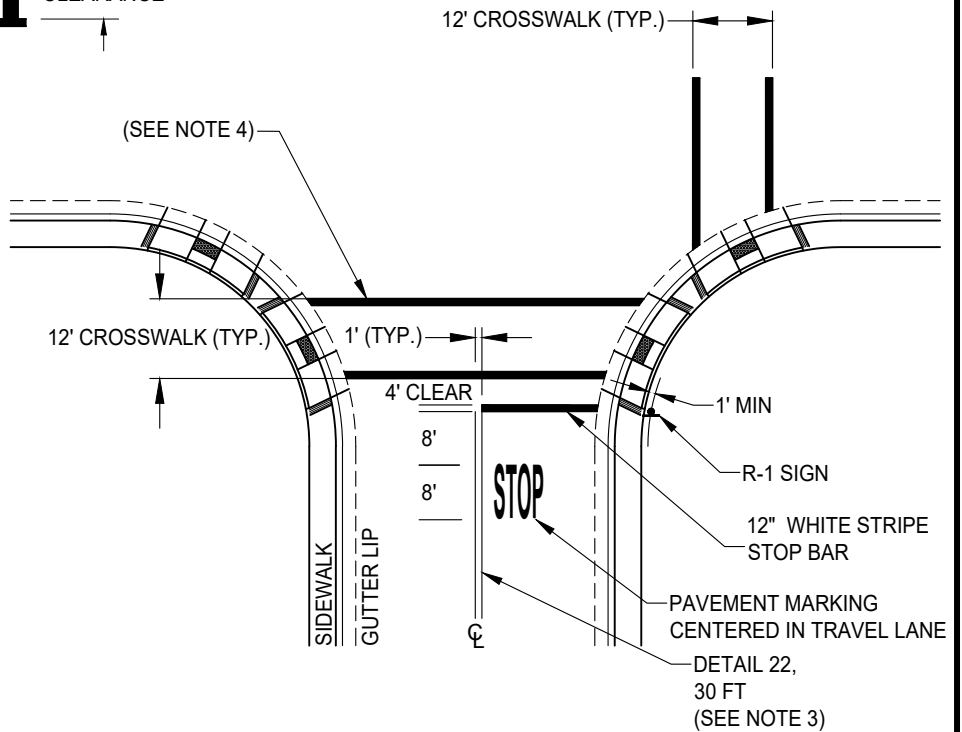

TYPICAL SIDEWALK RAMPS WITH CROSSWALK STRIPING

DATE		NOT TO SCALE	
REVISION	BY	APPROVED	DATE
1	AR	JA	04-02-2025
2	SJB	SMA	11-24-2025

CITY OF ELK GROVE - PUBLIC WORKS

**STOP SIGN AND STOP LEGEND
LOCATION**

APPROVED BY:  12-02-2025
CITY ENGINEER DATE



DRAWING NUMBER

T - 1

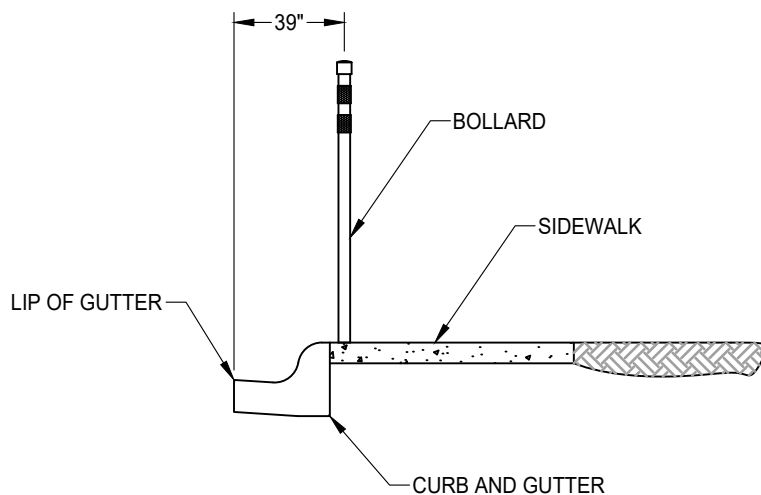
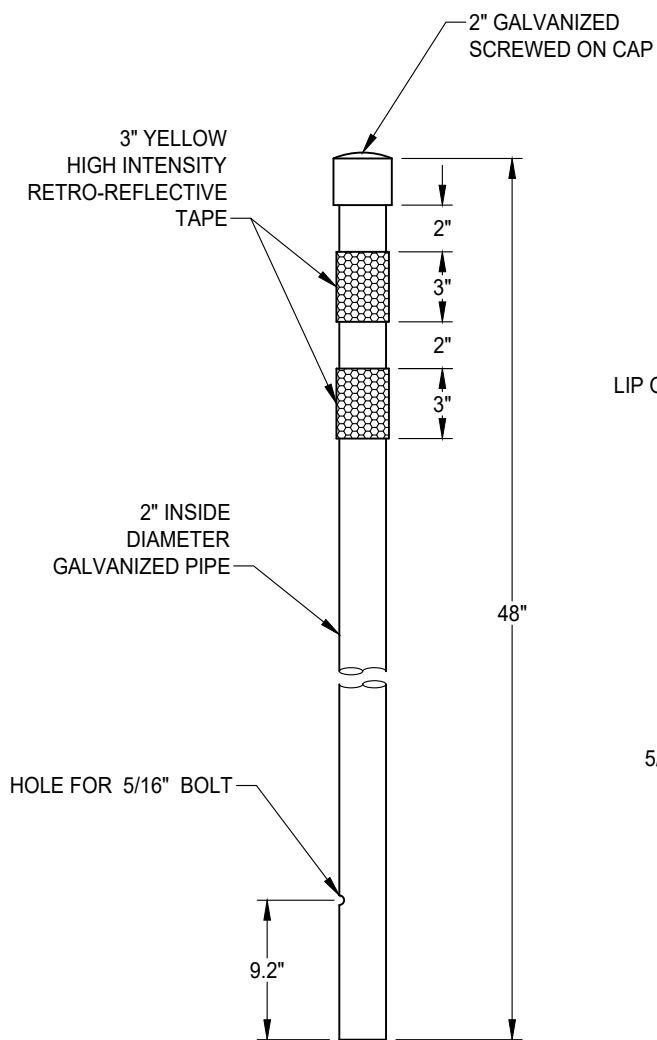

5/16" x 1" GALVANIZED BOLT
TO FACE THE STREET

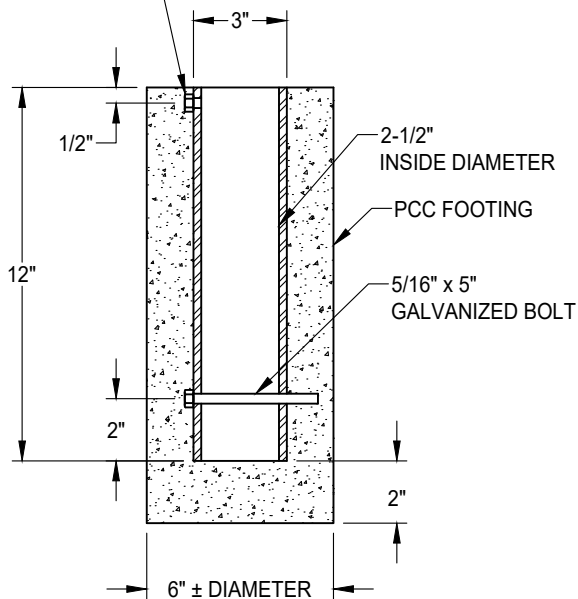

BOLLARD FOUNDATION DETAIL
NOT TO SCALE

NOTE:

1. INSTALL GALVANIZED STEEL BOLLARD AS NEEDED PER ENGINEER'S DIRECTION OR AS SPECIFIED ON THE PLANS.

DATE: 09/22/2017		NOT TO SCALE	
REVISION	BY	APPROVED	DATE

CITY OF ELK GROVE - PUBLIC WORKS

APPROVED BY:

Paul Murock

10/24/2018

CITY ENGINEER

DATE

BOLLARD DETAIL



DRAWING NUMBER

T - 2A

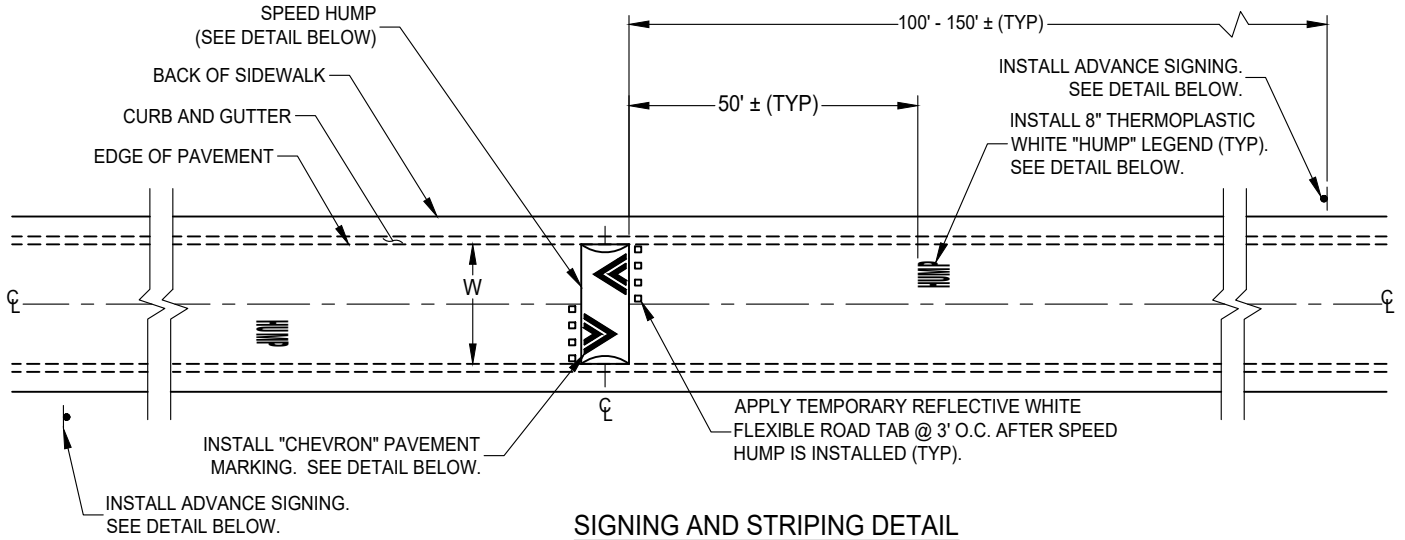

SIGNING AND STRIPING DETAIL
NOT TO SCALE

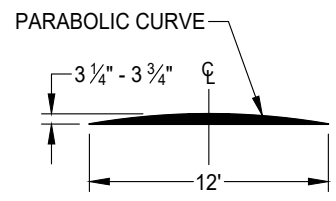

SECTION A-A
NOT TO SCALE

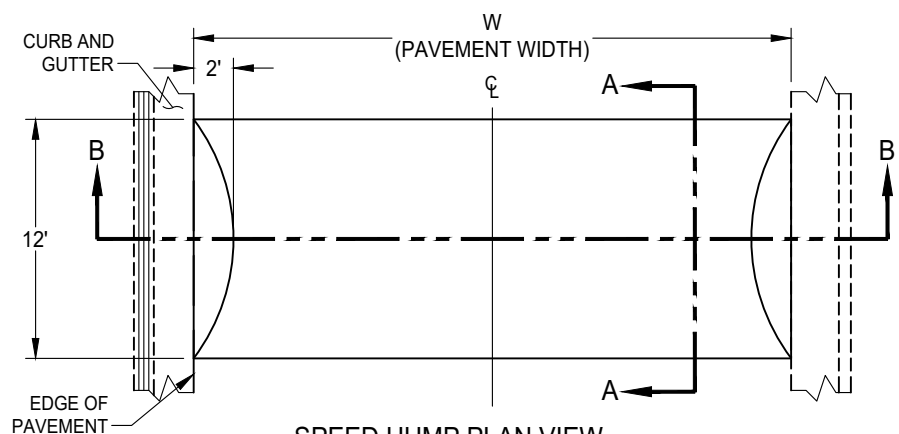

SPEED HUMP PLAN VIEW
NOT TO SCALE

NOTES:

1. INSTALL GALVANIZED STEEL BOLLARD AS NEEDED PER ENGINEER'S DIRECTION OR AS SPECIFIED ON THE PLANS. SEE STANDARD DRAWING NO. T-2A FOR DETAILS.
2. NO UTILITY APPURTENANCES ALLOWED WITHIN FOOTPRINT OF THE SPEED HUMP

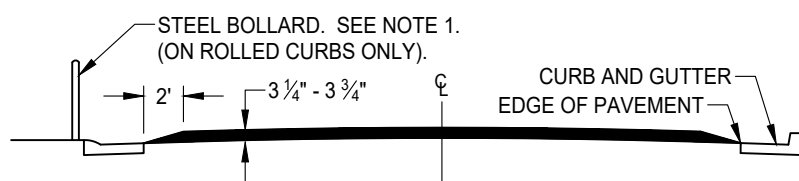

SECTION B-B
NOT TO SCALE

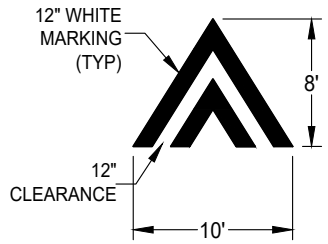

"CHEVRON" PAVEMENT MARKING DETAIL
NOT TO SCALE

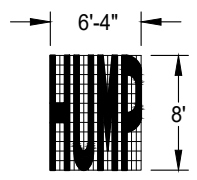

"HUMP" PAVEMENT MARKING
NOT TO SCALE

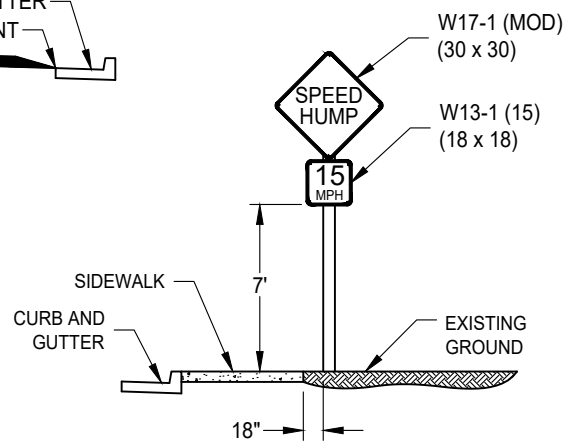

ADVANCE SIGNING
NOT TO SCALE

DATE: 09/22/2017		NOT TO SCALE	
REVISION	BY	APPROVED	DATE
1	SJB	SMA	03-28-2024

CITY OF ELK GROVE - PUBLIC WORKS

ASPHALT SPEED HUMP DETAIL
(W = 26' - 34')

APPROVED BY: _____
05-28-2024
CITY ENGINEER DATE

DRAWING NUMBER
T - 2B



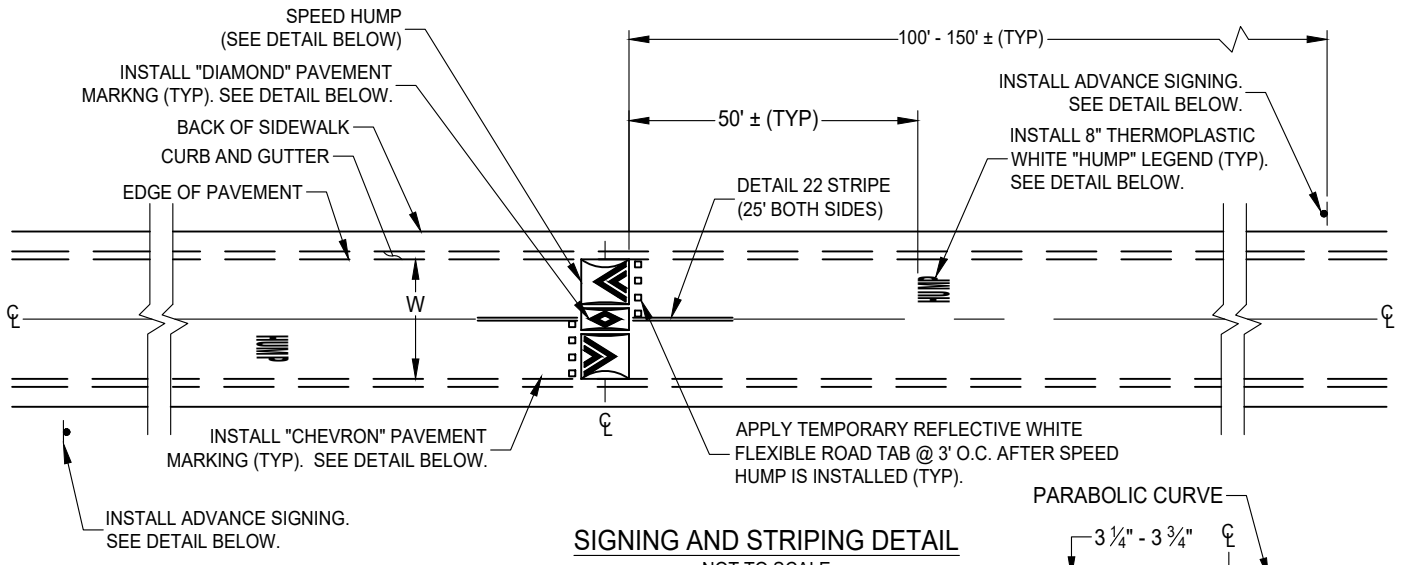

SIGNING AND STRIPING DETAIL
NOT TO SCALE

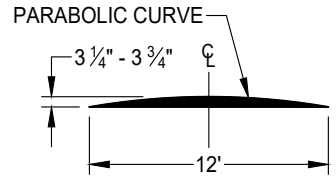

SECTION A-A
NOT TO SCALE

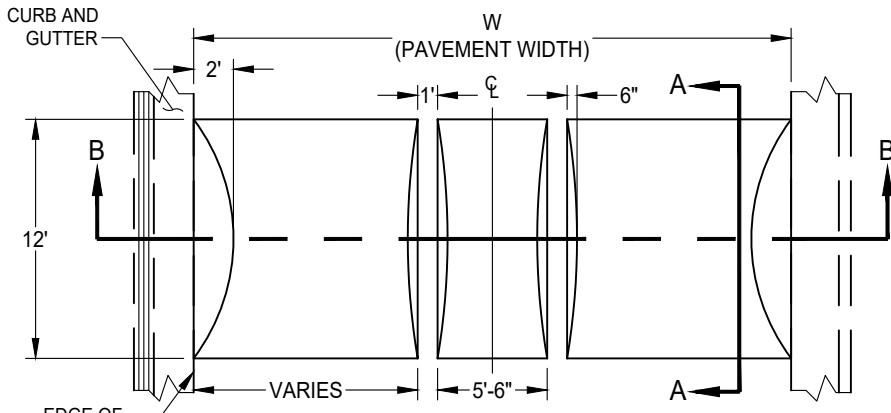
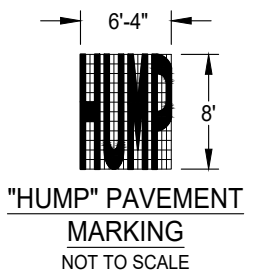

SPEED HUMP PLAN VIEW
NOT TO SCALE

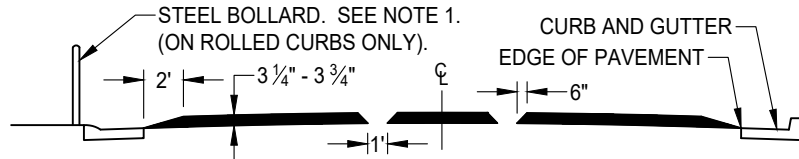

SECTION B-B
NOT TO SCALE

NOTES:

1. INSTALL GALVANIZED STEEL BOLLARD AS NEEDED PER ENGINEER'S DIRECTION OR AS SPECIFIED ON THE PLANS. SEE STANDARD DRAWING NO. T-2A FOR DETAILS.
2. NO UTILITY APPURTENANCES ALLOWED WITHIN FOOTPRINT OF THE SPEED HUMP

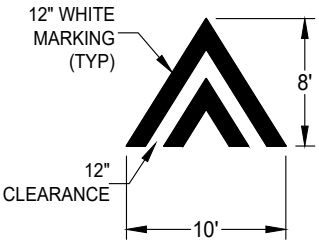

"CHEVRON" PAVEMENT MARKING DETAIL
NOT TO SCALE

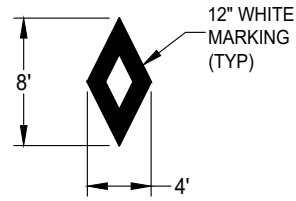

"DIAMOND" PAVEMENT MARKING DETAIL
NOT TO SCALE

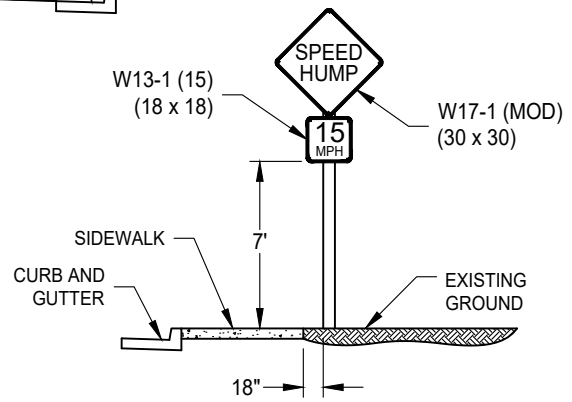

ADVANCE SIGNING
NOT TO SCALE

DATE: 09/22/2017		NOT TO SCALE	
REVISION	BY	APPROVED	DATE
1	SJB	SMA	03-28-2024

CITY OF ELK GROVE - PUBLIC WORKS

ASPHALT SPEED HUMP DETAIL (1)
(W = 26' - 34')

APPROVED BY: _____ 05-28-2024
CITY ENGINEER DATE

DRAWING NUMBER
T - 2C



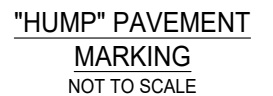
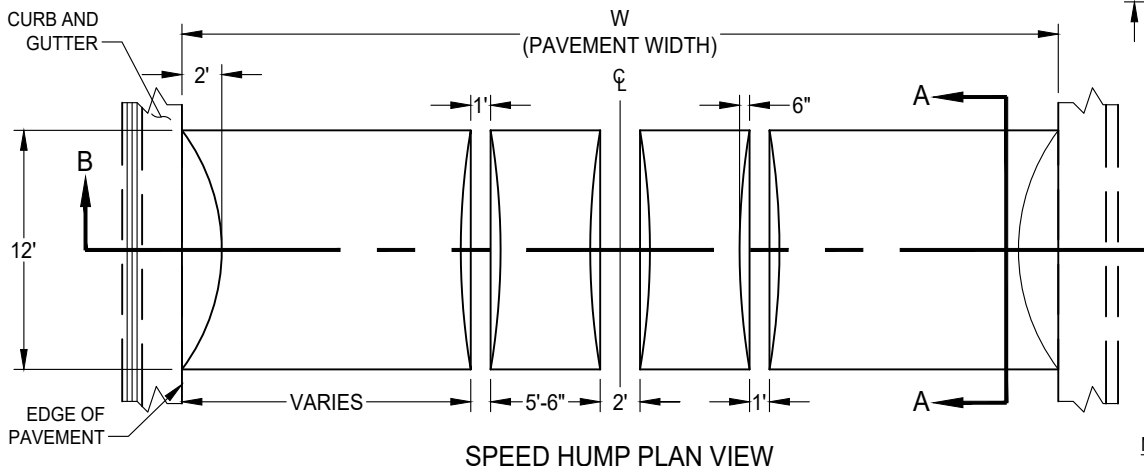
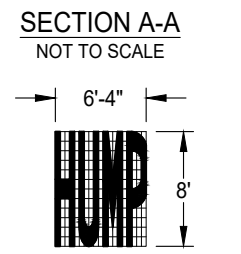
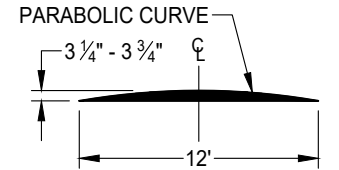
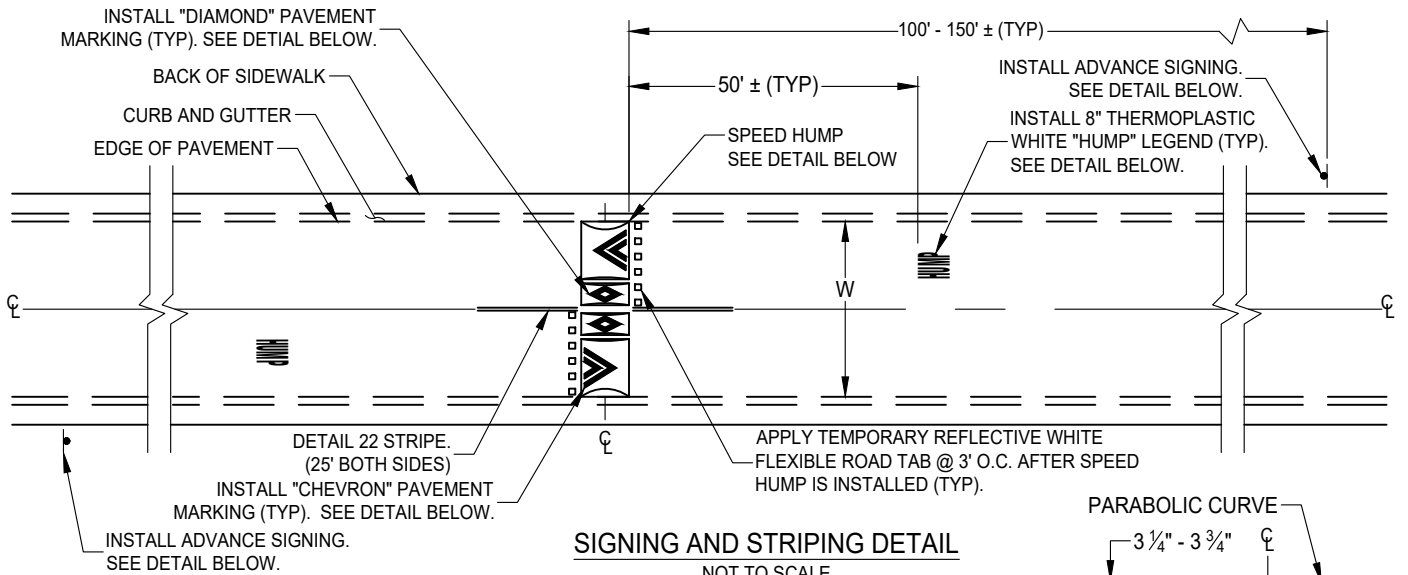

- NOTES:**
1. INSTALL GALVANIZED STEEL BOLLARD AS NEEDED PER ENGINEER'S DIRECTION OR AS SPECIFIED ON THE PLANS. SEE STANDARD DRAWING NO. T-2A FOR DETAILS.
 2. NO UTILITY APPURTENANCES ALLOWED WITHIN FOOTPRINT OF THE SPEED HUMP.

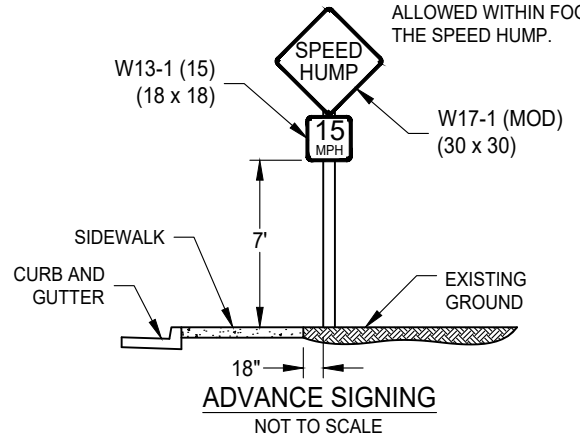
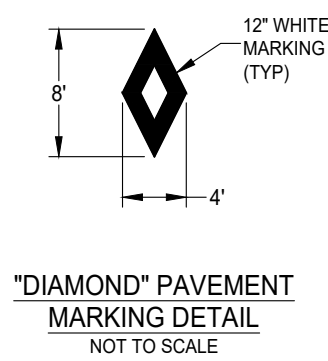
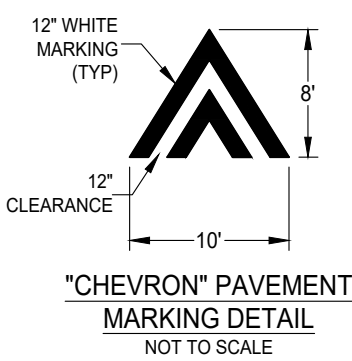
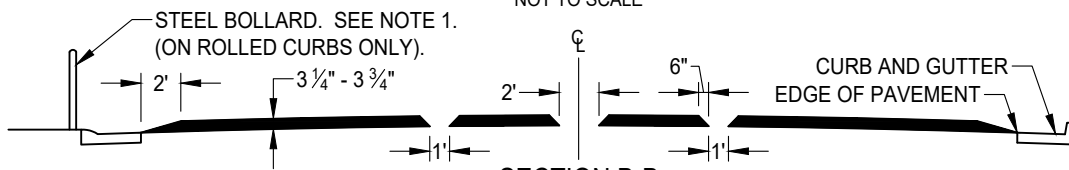

DATE: 09/22/2017		NOT TO SCALE	
REVISION	BY	APPROVED	DATE
1	SJB	SMA	03-28-2024

CITY OF ELK GROVE - PUBLIC WORKS

ASPHALT SPEED HUMP DETAIL (2)
(W = 36' - 44')

APPROVED BY: _____ 05-28-2024
CITY ENGINEER DATE

DRAWING NUMBER
T - 2D



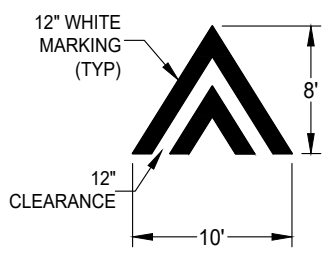
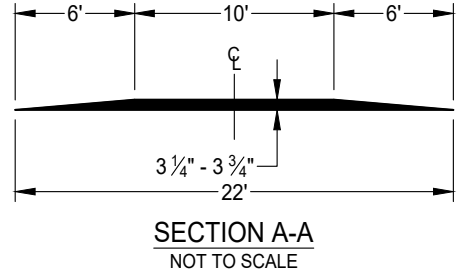
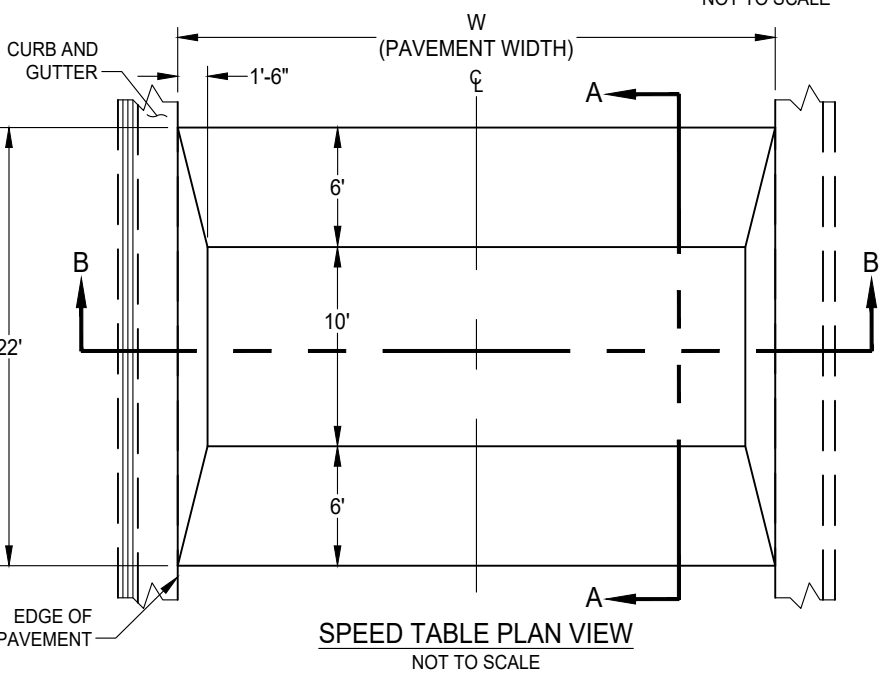
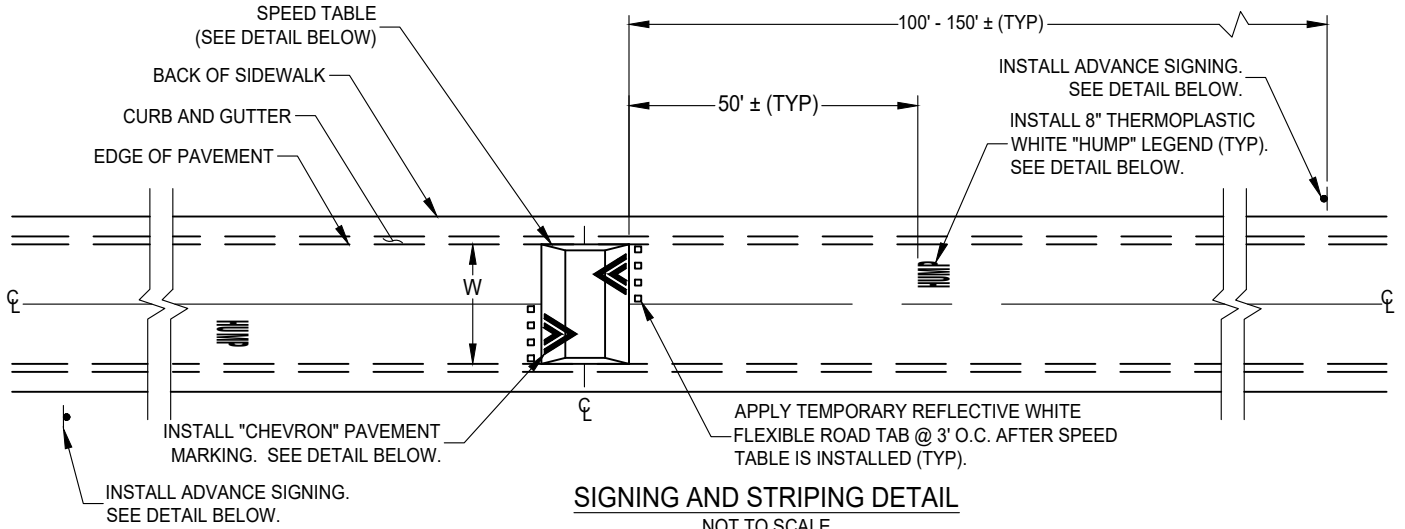

\"/>

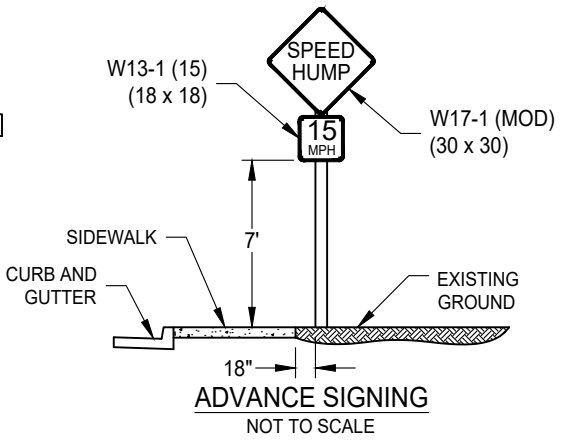
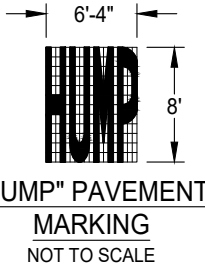
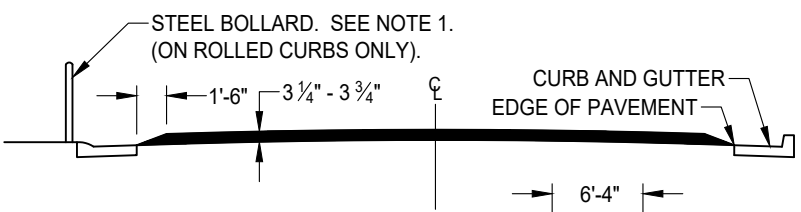

NOTES:

1. INSTALL GALVANIZED STEEL BOLLARD AS NEEDED PER ENGINEER'S DIRECTION OR AS SPECIFIED ON THE PLANS. SEE STANDARD DRAWING NO. T-2A FOR DETAILS.
2. NO UTILITY APPURTENANCES ALLOWED WITHIN FOOTPRINT OF THE SPEED TABLE

DATE: 09/22/2017		NOT TO SCALE	
REVISION	BY	APPROVED	DATE
1	SJB	SMA	03-28-2024

CITY OF ELK GROVE - PUBLIC WORKS

ASPHALT SPEED TABLE DETAIL
(W = 26' - 44')

APPROVED BY: _____
05-28-2024
DATE

CITY ENGINEER _____ DATE

DRAWING NUMBER
T - 2E





SIGN BLANKS: ALL STREET NAME SIGNS SHALL BE 10 INCHES IN HEIGHT, A MINIMUM OF 30 INCHES IN LENGTH AND A MAXIMUM OF 48 INCHES IN LENGTH. SIGN SHALL BE 0.125 INCH THICK, ASTM ALLOY 6061-T6, FLAT ALUMINUM FOR CENTER MOUNTED SIGNS.

SHEETING: REFLECTIVE SHEETING SHALL BE 3M DIAMOND GRADE OR EQUIVALENT (WHITE), OVERLAYED WITH ELECTRO CUT (EC) TRANSPARENT OVERLAY FILM (GREEN). NO PRINTED SIGNS ALLOWED.

STREET NAMES: STREET NAMES SHALL BE NO LONGER THAN 14 LETTERS LONG, INCLUDING SPACES AND SHALL BE USED TO DETERMINE SIGN LENGTH AS SPECIFIED ABOVE.

FONTS: ALL LETTERS AND NUMBERS SHALL BE HIGHWAY GOTHIC FONT "D". MINIMUM LETTER DIMENSIONS AS LISTED BELOW ARE TO BE USED WITH LONG STREET NAMES IN ORDER TO FIT NAMES ON SIGN BLANKS.

UPPER CASE LETTERS FOR STREET NAMES:	4 INCHES
LOWER CASE LETTERS FOR STREET NAMES:	3 INCHES
UPPER CASE LETTERS FOR STREET TYPES (I.E. BLVD, WAY, RD, ST)	2 INCHES

CITY LOGO: CITY LOGO SHALL BE 5 INCHES IN DIAMETER ELECTRO CUT (EC) FILM. A COPY OF THE LOGO CAN BE OBTAINED FROM THE ASSISTANT CITY CLERK.

COLORS: STREET NAME SIGN COLORS SHALL BE AS FOLLOWS:

BACKGROUND:	GREEN
TEXT:	WHITE
BORDER:	WHITE
CITY LOGO:	WHITE

LAYOUT: SIGNS SHALL BE DOUBLE FACED (FRONT AND REAR) . LAYOUT SHALL BE AS SHOWN ABOVE.

NOT TO SCALE			
REVISION	BY	APPROVED	DATE
01	STN	SA	08/18/2021

CITY OF ELK GROVE - PUBLIC WORKS

STREET NAME SIGN

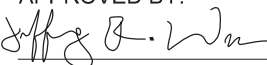
APPROVED BY:

 CITY ENGINEER 08-18-2021
 DATE



DRAWING NUMBER

T - 3



SIGN BLANKS: ALL STREET NAME SIGNS SHALL BE 10 INCHES IN HEIGHT, A MINIMUM OF 30 INCHES IN LENGTH AND A MAXIMUM OF 48 INCHES IN LENGTH. SIGN SHALL BE 0.125 INCH THICK, ASTM ALLOY 6061-T6, FLAT ALUMINUM FOR CENTER MOUNTED SIGNS.

SHEETING: REFLECTIVE SHEETING SHALL BE 3M DIAMOND GRADE OR EQUIVALENT (WHITE), OVERLAYED WITH ELECTRO CUT (EC) TRANSPARENT OVERLAY FILM (GREEN). NO PRINTED SIGNS ALLOWED.

STREET NAMES: STREET NAMES SHALL BE NO LONGER THAN 14 LETTERS LONG, INCLUDING SPACES AND SHALL BE USED TO DETERMINE SIGN LENGTH AS SPECIFIED ABOVE.

FONTS: ALL LETTERS AND NUMBERS SHALL BE HIGHWAY GOTHIC FONT "D". MINIMUM LETTER DIMENSIONS AS LISTED BELOW ARE TO BE USED WITH LONG STREET NAMES IN ORDER TO FIT NAMES ON SIGN BLANKS.

UPPER CASE LETTERS FOR STREET NAMES:	4 INCHES
LOWER CASE LETTERS FOR STREET NAMES:	3 INCHES
UPPER CASE LETTERS FOR STREET TYPES (I.E. BLVD, WAY, RD, ST)	2 INCHES

CITY LOGO: CITY LOGO SHALL BE 5 INCHES IN DIAMETER ELECTRO CUT (EC) FILM. A COPY OF THE LOGO CAN BE OBTAINED FROM THE ASSISTANT CITY CLERK.

COLORS: STREET NAME SIGN COLORS SHALL BE AS FOLLOWS:

BACKGROUND:	GREEN
TEXT:	WHITE
BORDER:	WHITE
CITY LOGO:	WHITE

LAYOUT: SIGNS SHALL BE DOUBLE FACED (FRONT AND REAR). LAYOUT SHALL BE AS SHOWN ABOVE.

NOT TO SCALE			
REVISION	BY	APPROVED	DATE
1	STN	SA	08-18-2021

CITY OF ELK GROVE - PUBLIC WORKS

PRIVATE STREET NAME SIGN

APPROVED BY:

Jeffrey B. Wan 08-18-2021
 CITY ENGINEER DATE

DRAWING NUMBER

T - 4



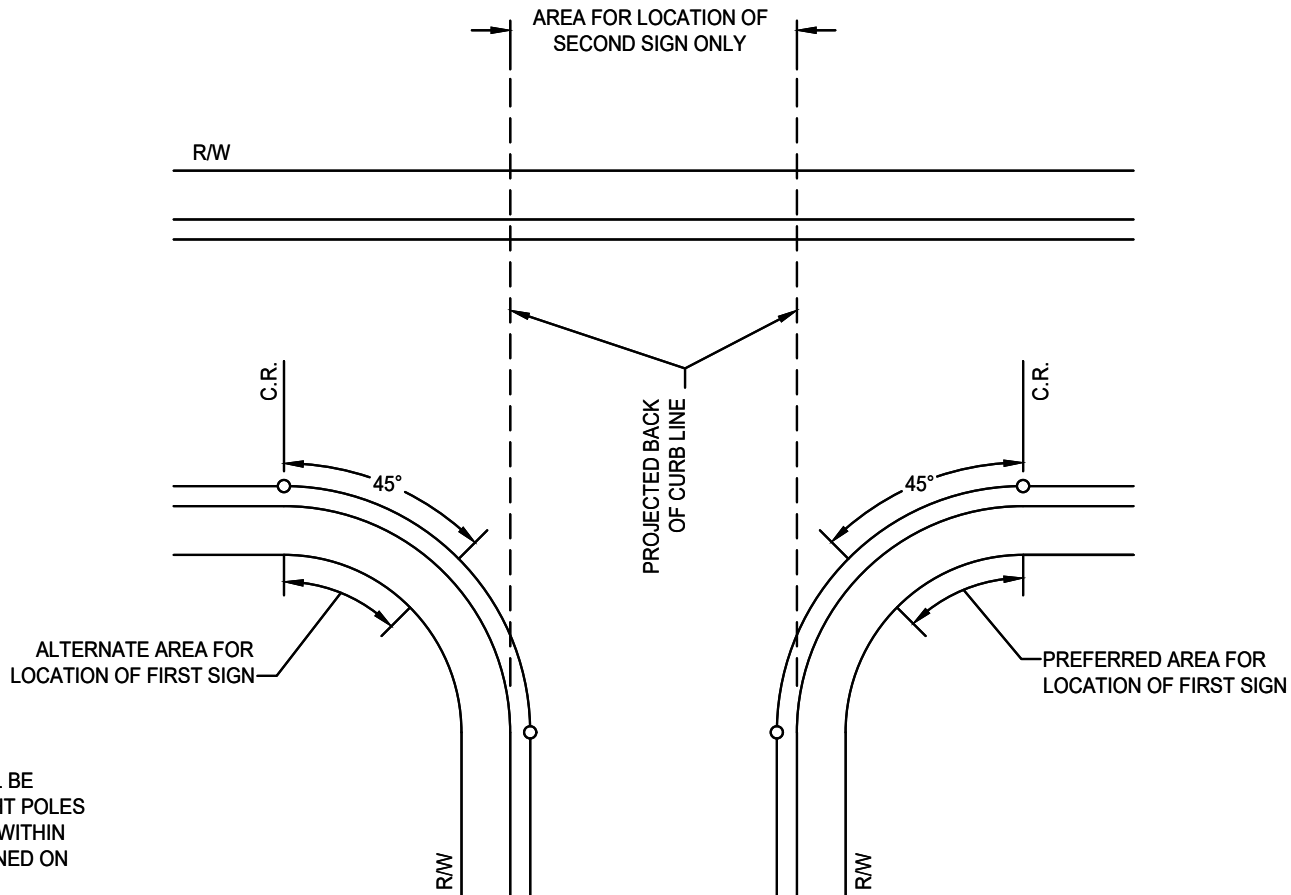

NOTES:

1. STREET NAME SIGNS SHALL BE INSTALLED ON STREET LIGHT POLES WHEN THEY ARE LOCATED WITHIN THE LOCATION LIMITS DEFINED ON THIS DETAIL.
2. THE LOCATION FOR SECOND SIGN SHALL BE USED ONLY WHEN 2 (TWO) SETS OF STREET NAME SIGNS ARE REQUIRED AS SHOWN IN STANDARD DRAWING NUMBER T-6A.
3. ALL OTHER STREET NAME SIGN REQUIREMENTS IN SECTIONS 4-21 AND 4-22 OF THE CITY IMPROVEMENT STANDARDS AND CITY STANDARD DRAWINGS T-3, T-3.1, T-4, T-5B, T-6A AND T-6B SHALL APPLY.

DATE: 09/22/2007		NOT TO SCALE	
REVISION	BY	APPROVED	DATE

CITY OF ELK GROVE - PUBLIC WORKS

STREET NAME SIGN ON STREET LIGHT POLE PLACEMENT DETAIL

APPROVED BY:
Paul Murock
CITY ENGINEER

10/24/2018
DATE

DRAWING NUMBER
T - 5A



CANTILEVER TWO-SIDED SIGNS SHALL BE MOUNTED ON SIGNAL POLES AND LUMINAIRE POLES AWAY FROM THE CROSS STREET WITH 30-INCH BRACKETS, TOP AND BOTTOM, (SEE NOTE). BRACKETS SHALL BE FASTENED TO POLES WITH TWO (2) 0.750 INCH WIDE BY 0.30 INCH THICK TYPE 201 STAINLESS STEEL BANDS WITH HEAVY DUTY BUCKLE AND A MINIMUM OF TWO (2) VANDAL PROOF SCREWS SHALL AFFIX THE STREET SIGN TO THE BRACKET. THE SCREWS SHALL PASS THROUGH THE BRACKET AND SIGN. AT LOCATIONS WITH TWO (2) SIGNS, ONE PERPENDICULAR TO THE CENTERLINE OF EACH ROADWAY, THE SIGNS SHALL EACH HAVE TWO (2) BANDS AFFIXING THE BRACKET TO THE POLE. ONE SIGN WILL BE BELOW THE OTHER SIGN.

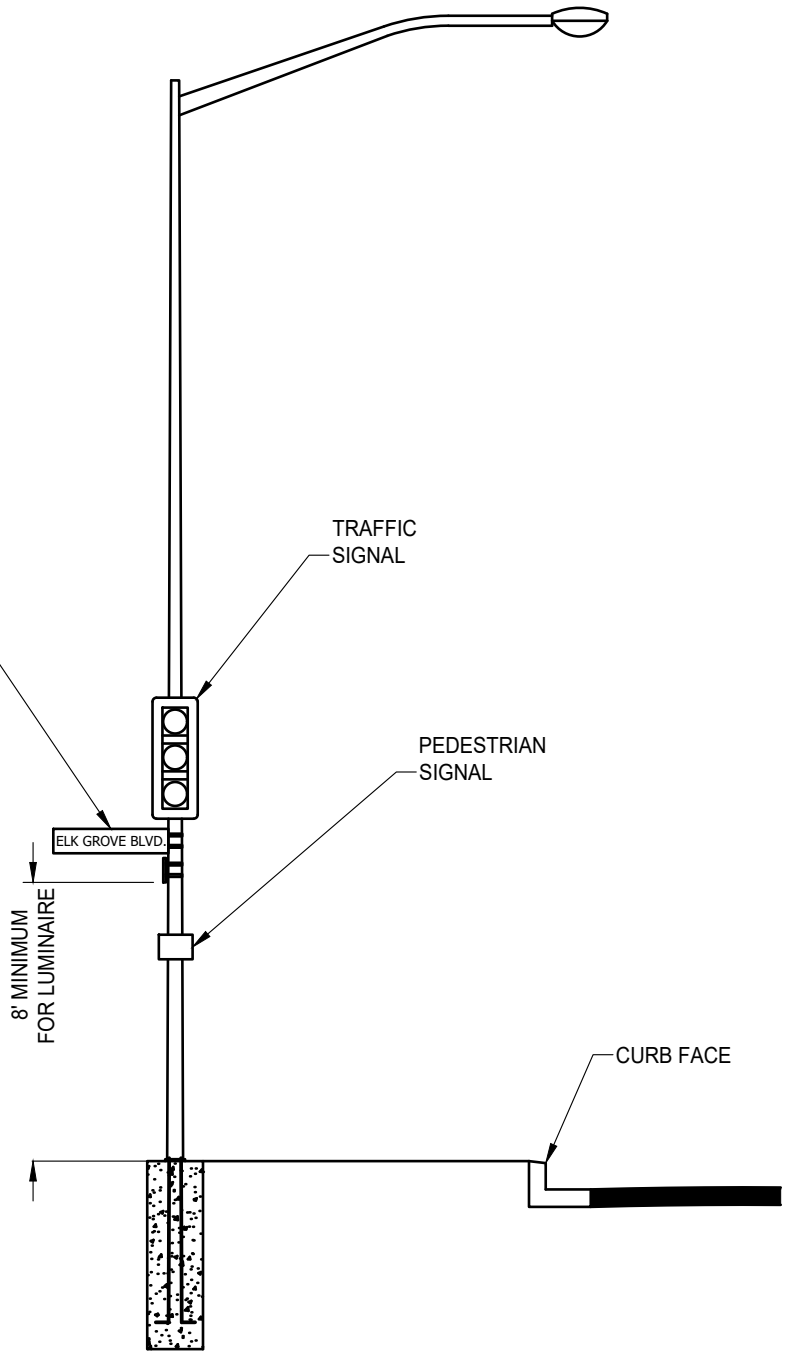

NOTE:

- BRACKETS SHALL BE 30-INCH IN LENGTH, TOP AND BOTTOM OF SIGN, AND SHALL BE ASSEMBLED BY ATTACHING AN EXTRUDED ALUMINUM HEAD TO AN EXTENDED ALUMINUM "T" CHANNEL. THE BRACKET SHALL BE MADE FROM 6082-T6 ALUMINUM WITH "T" SECTION SHALL BE MADE FROM 6062-T6 ALUMINUM. THESE CANTILEVER ASSEMBLIES SHALL ACCOMMODATE UP TO 3/4" INCH STAINLESS STEEL BANDING THAT CAN BE DOUBLE WRAPPED FOR MOUNTING. THE CANTILEVER ARM SYSTEM SHALL ACCEPT SIGNS UP TO 0.125-INCH THICK. CANTILEVER ARMS SHALL BE ATTACHED TO BOTH THE TOP AND BOTTOM OF SIGN. CANTILEVER ARMS SHALL BE DESIGNED TO SUPPORT UP TO A SIGN AREA OF 6-SQ. FT. COLOR OF CANTILEVER ASSEMBLY AND BANDS SHALL MATCH POLE COLOR.

DATE: 09/22/2017		NOT TO SCALE	
REVISION	BY	APPROVED	DATE
1	SJB	SMA	03-28-2024

CITY OF ELK GROVE - PUBLIC WORKS

**STREET NAME SIGN ON
ELECTROLIERS**

APPROVED BY: _____
05-28-2024
DATE

CITY ENGINEER

DRAWING NUMBER
T - 5B



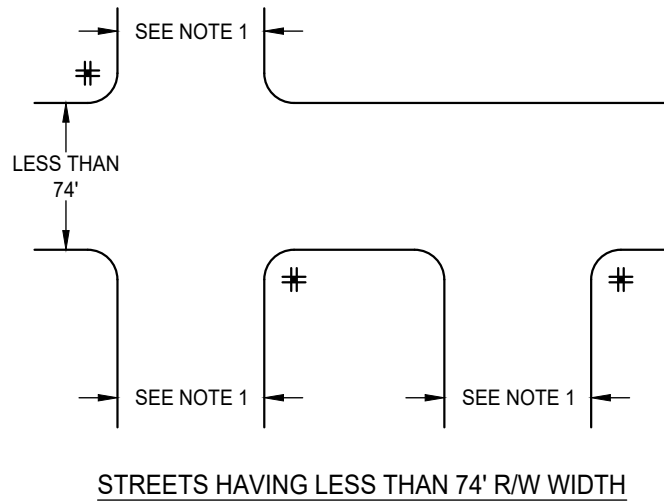
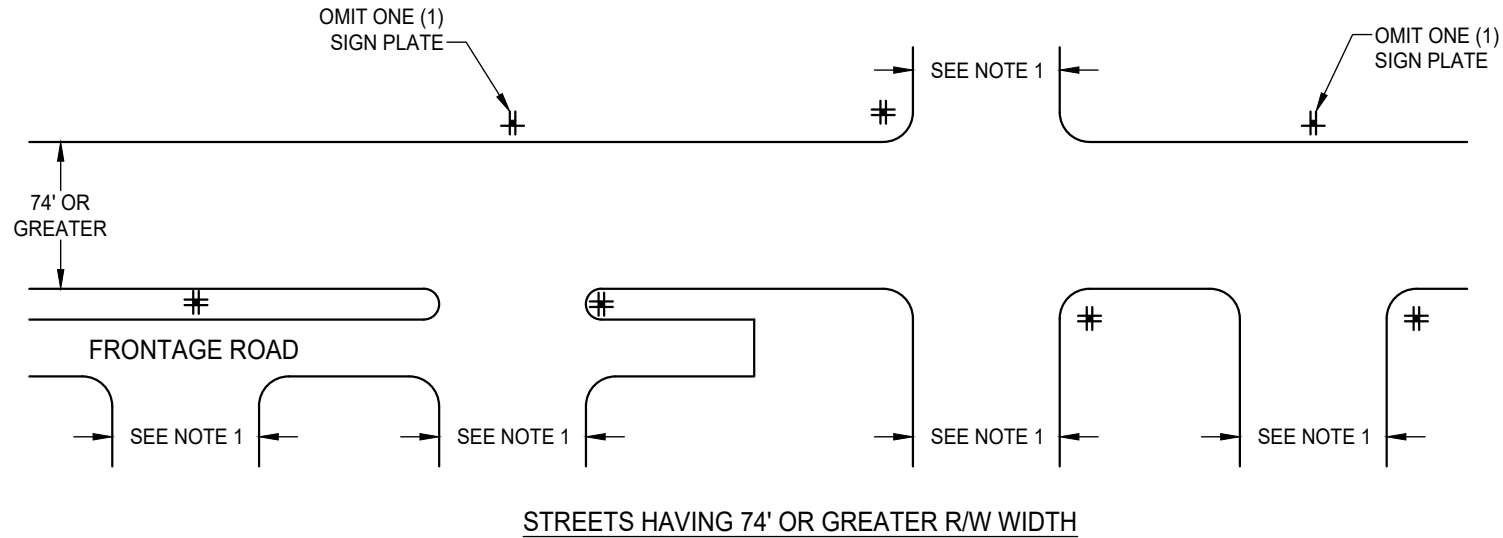

NOTES:

1. SIDE STREETS INDICATED ARE STREETS WITH R/W WIDTHS EQUAL TO OR LESS THAN R/W WIDTH FOR THROUGH STREET
2. STREET SIGNS ARE TO BE LOCATED AT MID-RETURN APPROXIMATELY 30 INCHES BEHIND THE FACE OF CURB OR 6" BEHIND ATTACHED SIDEWALKS. SEE STANDARD DRAWING T-1 WHEN COMBINED WITH A STOP SIGN.
3. SIGNS SHALL BE INSTALLED ON NORTHWEST AND SOUTHEAST CORNERS OF INTERSECTIONS. SIGNS SHALL BE INSTALLED ON STREET LIGHTING STANDARD WHEN APPROPRIATE AND AS APPROVED BY CITY.
4. CITY TO REVIEW AND APPROVE SIGN LOCATIONS PRIOR TO INSTALLATION.
5. SEE STANDARD DRAWINGS T-1, T-3, T-4, T-5A, T-5B, AND T-6B.

LEGEND:

STANDARD STREET NAME SIGN INSTALLATION. FOUR (4) SIGN PLATES ON POST OR ON STREET LIGHT POLE.

THREE (3) SIGN PLATES ON POST OR ON STREET LIGHT POLE.

DATE 09/22/2007		NOT TO SCALE	
REVISION	BY	APPROVED	DATE
1	STN	JRW	02-16-2021
2	SJB	SMA	03-07-2025
3	SJB	SMA	10-27-2025

CITY OF ELK GROVE - PUBLIC WORKS

STREET NAME SIGN GENERAL LOCATION

APPROVED BY:

 11-14-2025

CITY ENGINEER

DATE



DRAWING NUMBER

T - 6A

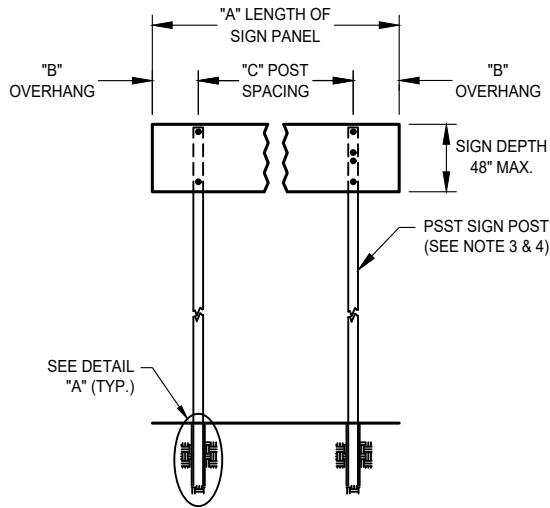
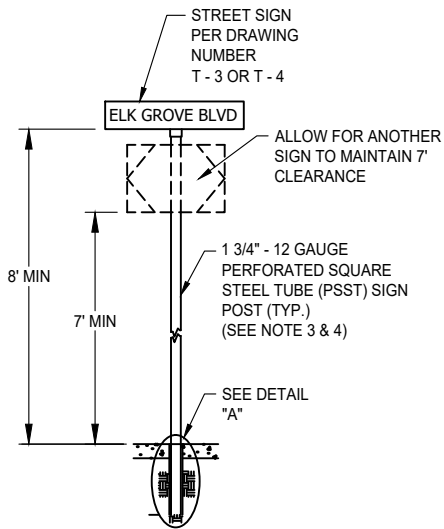

Sign Panel Length	Sign Panel Overhang	Post Spacing
"A"	"B"	"C"
3' - 6"	6"	2' - 6"
4' - 0"	6"	3' - 0"
4' - 6"	6"	3' - 6"
4' - 8"	7"	3' - 6"
5' - 6"	1' - 0"	3' - 6"
6' - 0"	1' - 0"	4' - 0"

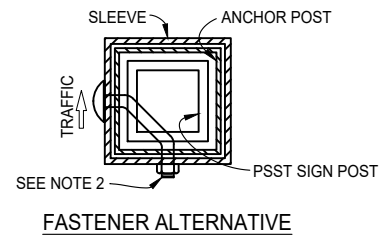
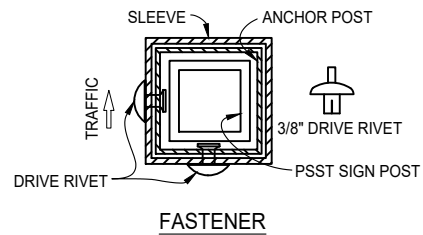
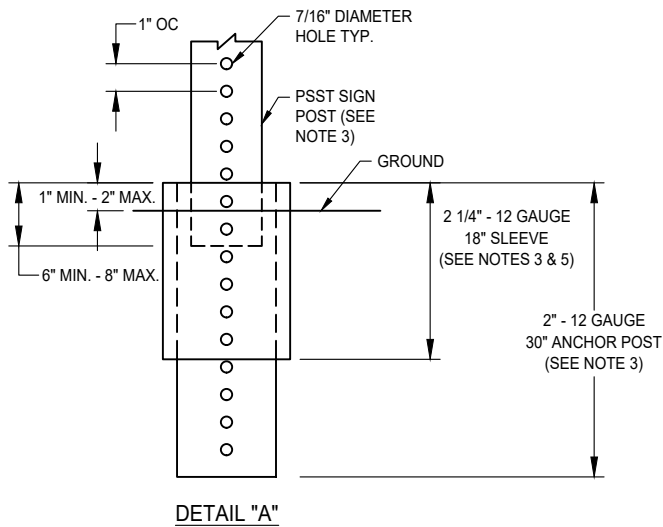

NOTES:

1. BOTTOM OF LOWEST STREET SIGN TO BE MOUNTED EIGHT (8) FEET ABOVE THE GROUND OR SIDEWALK PER DETAIL "A" SHOWN ON THIS SHEET EXCEPT, WHEN STOP SIGN IS MOUNTED ON SAME POST AS A STREET SIGN, BOTTOM OF STOP SIGN SHALL BE MOUNTED SEVEN (7) FEET ABOVE THE GROUND OR SIDEWALK AND STREET NAME SIGN TO BE MOUNTED DIRECTLY ABOVE THE STOP SIGN. IN NO CASE SHALL THE BOTTOM OF THE LOWEST SIGN BE LESS THAN SEVEN (7) FEET ABOVE THE GROUND OR SIDEWALK LEVEL.
2. USE TWO DRIVE RIVETS TO FASTEN ASSEMBLED SIGN AND SIGN POST INTO ANCHOR SLEEVE. INSTALL DRIVE RIVETS OR FASTNER ALTERNATIVE INTO THE SIDES FACING TRAFFIC.
3. PSST SIGN POST, ANCHOR POST, AND SLEEVE SHALL BE GALVANIZED AND OF THE SAME GAUGE.
4. PSST SIGN POST PER STANDARD SPECIFICATIONS.
5. SLEEVE PLACE IN CONCRETE SHALL BE SOLID WITH ONLY ONE HOLE AT THE TOP FOR DRIVE RIVET OR FASTENER.
6. SHALL BE 90°, HAWKINS PART NUMBER V14F-(HD)SL-105(90)-.0.125 (OR EQUAL). STREET LIGHT STANDARD BRACKET SHALL BE HAWKINS, WING BRACKET, PART NO. V14F-(HD)SL-AB-0.125 OR EQUAL.

DATE: 09/22/2017		NOT TO SCALE	
REVISION	BY	APPROVED	DATE
1	SJB	SMA	04-22-2024

CITY OF ELK GROVE - PUBLIC WORKS

APPROVED BY:  05-08-2024
CITY ENGINEER DATE

SIGN POST



DRAWING NUMBER
T - 6B

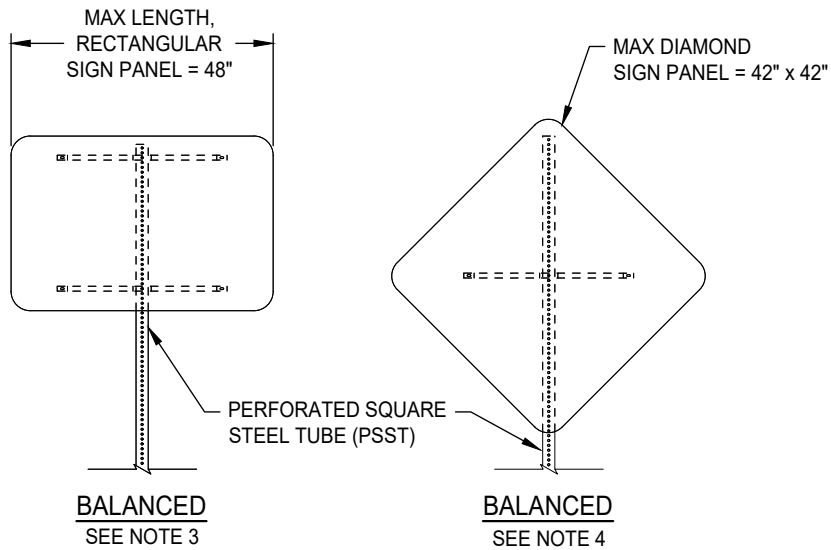

SINGLE POST INSTALLATION

NOTES:

1. BALANCED PSST POST INSTALLATIONS OF SIGN PANEL REQUIRE BACK BRACES WHEN 3' - 0" OR MORE IN LENGTH.
2. WOOD BLOCK SPACERS ARE NOT REQUIRED FOR SIGNS MOUNTED ON PSST POST.
3. ATTACH RECTANGULAR SIGN PANEL TO PSST POST AT THE TOP, BOTTOM, AND CENTER.
4. ATTACH DIAMOND SIGN PANEL TO PSST POST AT TOP, BOTTOM, AND CENTER.

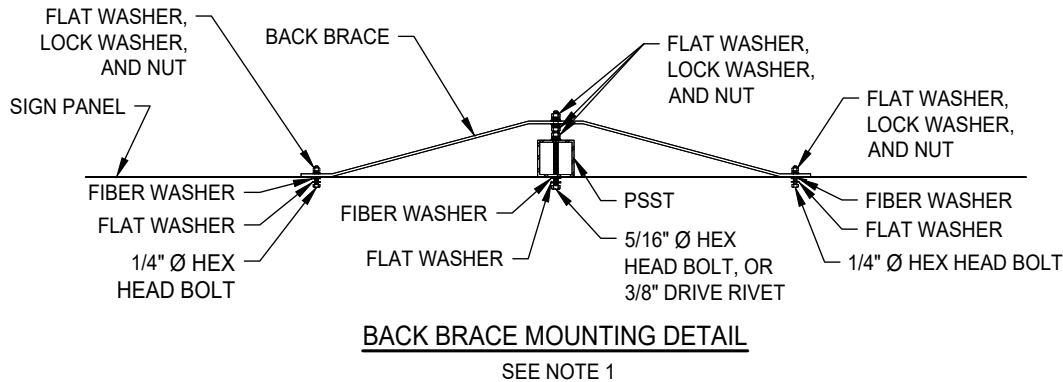
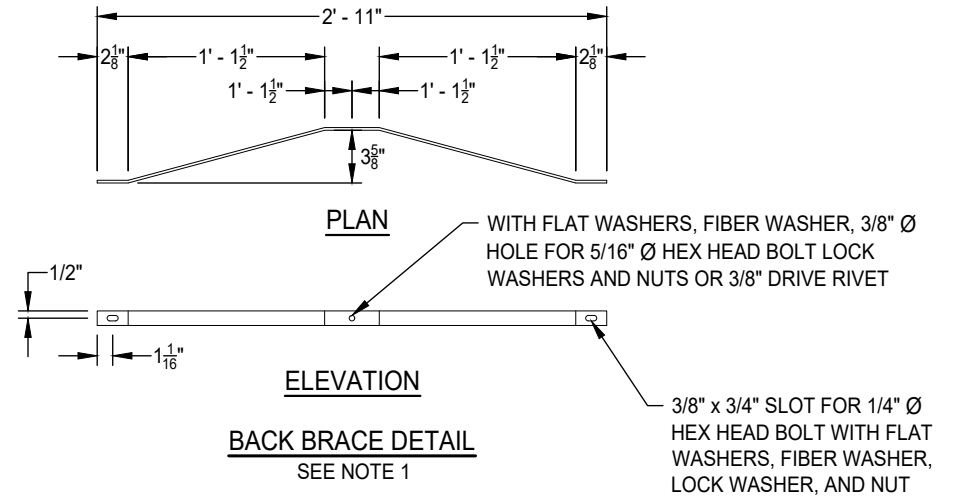

DATE 04/23/2024		NOT TO SCALE	
REVISION	BY	APPROVED	DATE

CITY OF ELK GROVE - PUBLIC WORKS

APPROVED BY:

 05-08-2024
 CITY ENGINEER DATE

SIGN BACK BRACING

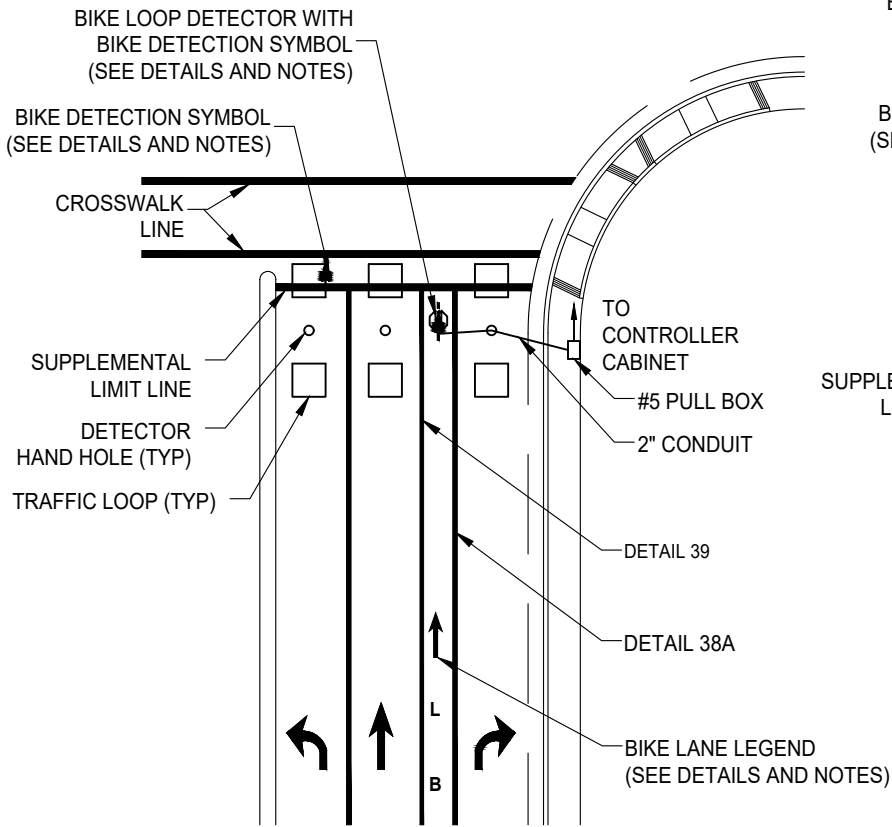

DRAWING NUMBER

T - 6C



BIKE LOOP INSTALLATION AT MAJOR INTERSECTION WITH RIGHT TURN LANE

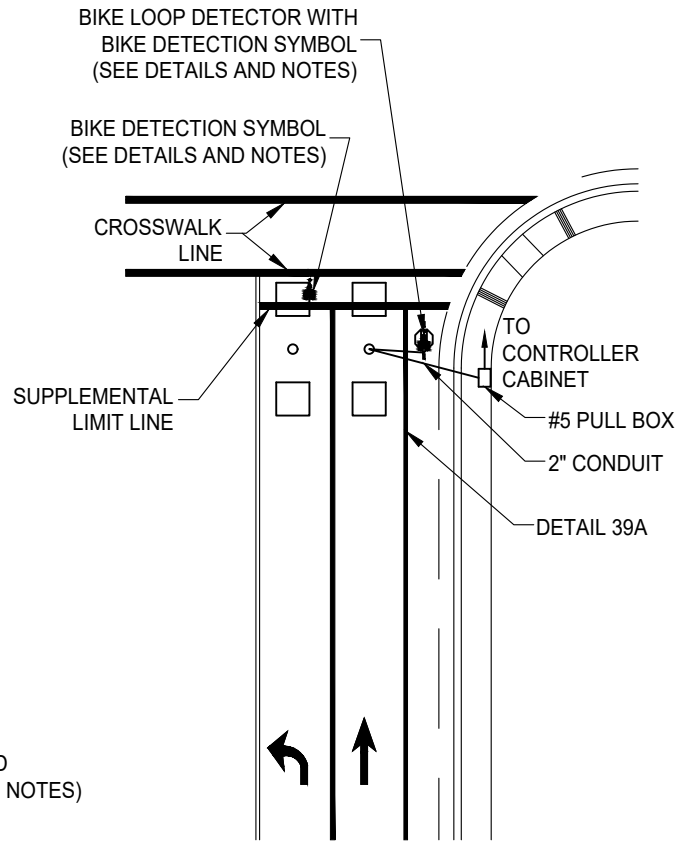

BIKE LOOP INSTALLATION ADJACENT TO CURB AND GUTTER

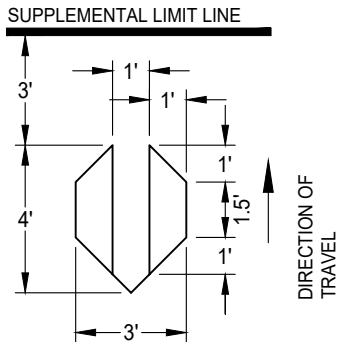

BIKE LOOP DETECTOR DETAIL
NOT TO SCALE

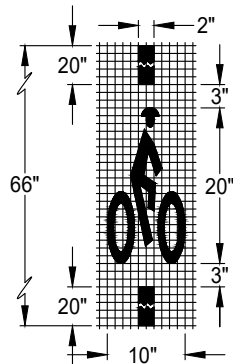

BIKE DETECTION SYMBOL DETAIL
NOT TO SCALE

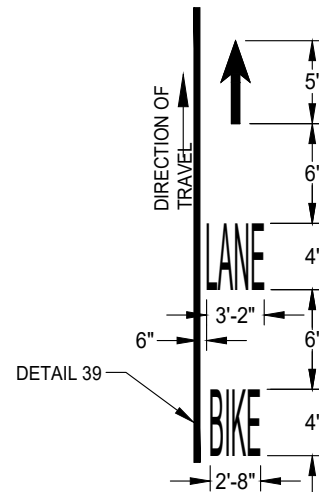

BIKE LANE LEGEND DETAIL
NOT TO SCALE

SEE THE CURRENT VERSION OF THE CALIFORNIA MUTCD FOR PAVEMENT MARKING, ARROW, AND LEGEND

NOTES:

- BIKE LOOP SHALL BE INSTALLED WITH CONDUIT, DETECTOR HANDHOLE (DH) AND DETECTOR LEAD IN CABLE (DLC) AND CONNECTED IN CONTROLLER WITH SEPARATE CHANNEL FOR OPERATION, UNLESS OTHERWISE NOTED ON THE PLANS.
- FOR BIKE LANE WITH LESS THAN 3 FEET IN WIDTH, MEASURING FROM BIKE LANE STRIPE AND LIP OF GUTTER, USE 3/4 SIZE OF BIKE LANE LEGEND.
- BIKE LANE LEGENDS, ARROWS, AND BIKE DETENTION SYMBOLS SHALL CONFORM TO STATE STANDARDS SPECIFICATIONS SECTION 84-2.02.
- BIKE DETECTION SYMBOL SHALL BE INSTALLED ON LOOP DETECTOR FOR LEFT TURN LANE, BIKE LANE AND OUTSIDE THROUGH LANE WHERE NO BIKE LANE IS PROPOSED. FOR DUAL LEFT TURN LANES, ONLY THE OUTSIDE LEFT TURN LANE SHALL BE INSTALLED WITH BIKE DETECTION SYMBOL. COORDINATE WITH SIGNAL CONTRACTOR AND CITY INSPECTOR FOR EXACT LOCATION OF DETECTION.

DATE: 09/22/2007		NOT TO SCALE	
REVISION	BY	APPROVED	DATE
1	SN	SA	7-29-2021
2	SJB	SMA	11-14-2025

CITY OF ELK GROVE - PUBLIC WORKS

BIKE LOOP AND BIKE LEGEND INSTALLATION DETAIL

APPROVED BY: _____ 11-14-2025
CITY ENGINEER DATE

DRAWING NUMBER
T - 7



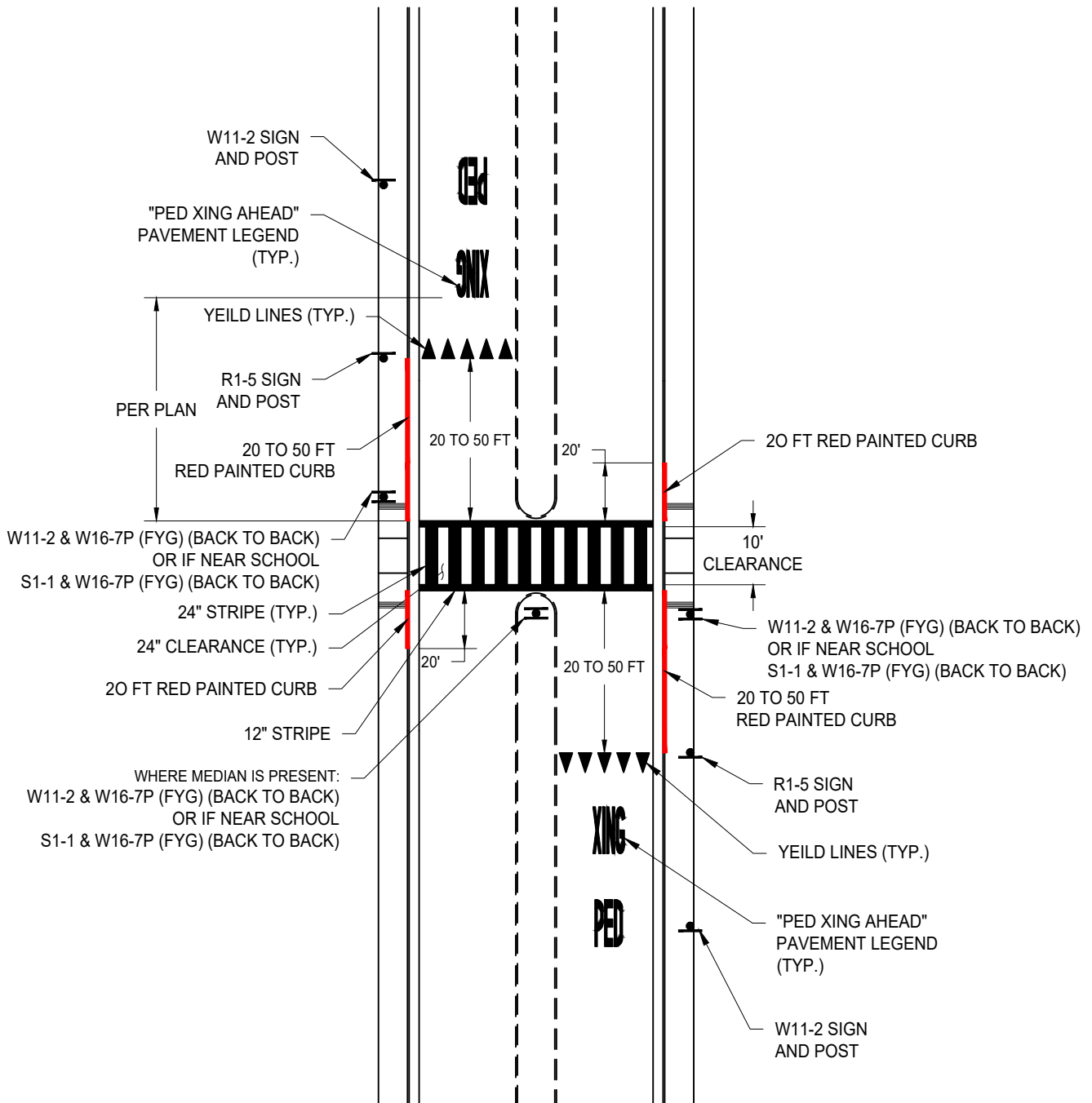

NOTES:

- CROSSWALK STRIPE SHALL BE EITHER YELLOW OR WHITE AS DIRECTED BY THE ENGINEER OR DETAILED ON THE PLANS, CROSSWALKS WITHIN 500FT OF A SCHOOL SHALL BE LADDER TYPE AND PAINTED YELLOW.
- ALL SIGNS SHALL BE HIGH VISIBILITY YELLOW

DATE: 09/22/2017		NOT TO SCALE	
REVISION	BY	APPROVED	DATE
1	SJB	SMA	03-28-2024
2	AR	JA	08-19-2025

CITY OF ELK GROVE - PUBLIC WORKS

**CROSSWALK AT
UNCONTROLLED LOCATIONS**

APPROVED BY: _____
11-17-2025
 CITY ENGINEER DATE

DRAWING NUMBER
T - 8A



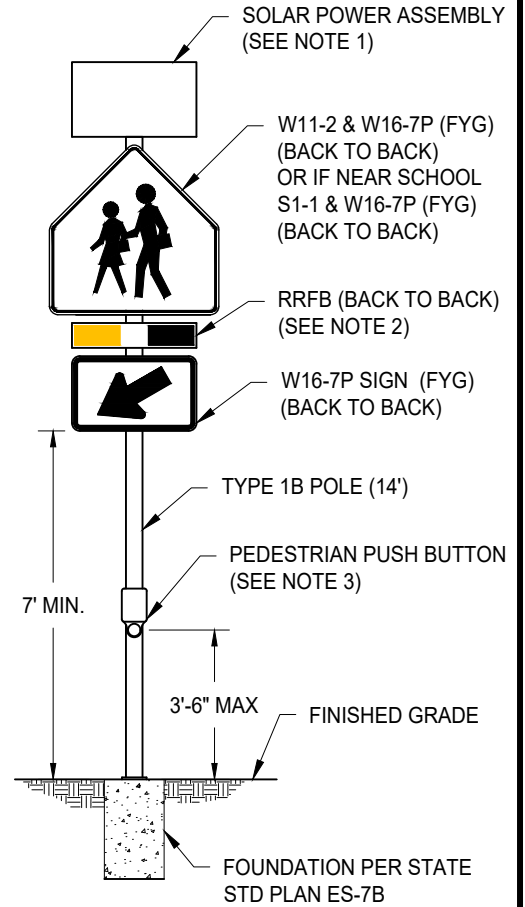
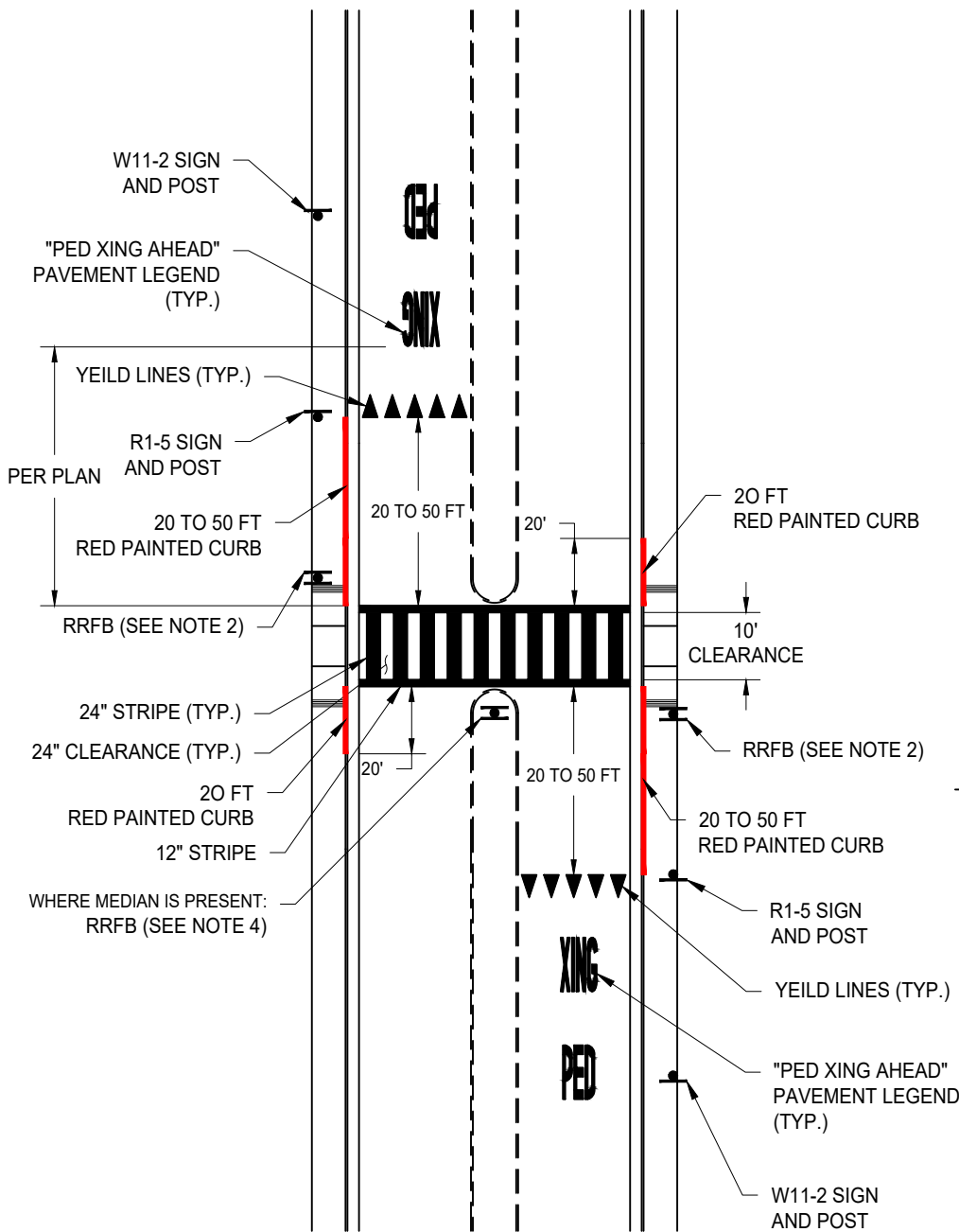

RRFB DETAIL

NOTES:

1. SELF CONTAINED SOLAR ENGINE THAT HOUSES THE ENERGY MANAGEMENT SYSTEM, ON BOARD USER INTERFACE, WIRELESS COMMUNICATIONS BETWEEN UNITS, BATTERIES AND SOLAR PANEL.
2. RECTANGULAR RAPID FLASHING BEACON (RRFB) INDICATIONS SHALL FLASH IN A RAPID ALTERNATING "WIG-WAG" FLASHING SEQUENCE. RRFB SHALL BE EITHER MODEL 2180-RRFB-XL BY TAPCO TRAFFIC AND PARKING CONTROL CO. INC, MODEL R920 BY CARMANAH TECHNOLOGIES CORP., OR MODEL TS60-RRFB BY TRAFFIC SAFETY CORP., OR APPROVED EQUAL.
3. PEDESTRIAN PUSH BUTTON (PPB) SHALL BE TYPE B, LARGE A.D.A. TYPE WITH TWO-INCH DIA. BUTTON. PPB HOUSING SHALL BE EITHER DIE-CAST OR PERMANENT MOLD CAST ALUMINUM. PEDESTRIAN SIGN SHALL CONFORM TO STANDARD SIGN R10-25 OF THE CALIFORNIA MUTCD.
4. INSTALL RRFB IN THE MEDIAN ISLAND WHEN APPLICABLE (EXCLUDING W16-7P SIGN PLATE).
5. CROSSWALK STRIPE SHALL BE EITHER YELLOW OR WHITE AS DIRECTED BY THE ENGINEER OR DETAILED ON THE PLANS, CROSSWALKS WITHIN 500FT OF A SCHOOL SHALL BE LADDER TYPE AND PAINTED YELLOW.
6. ALL SIGNS SHALL BE HIGH VISIBILITY YELLOW

DATE: 09/22/2017		NOT TO SCALE	
REVISION	BY	APPROVED	DATE
1	SJB	SMA	03-28-2024
2	AR	JA	04-02-2025

CITY OF ELK GROVE - PUBLIC WORKS

**RRFB AT
UNCONTROLLED LOCATIONS**

APPROVED BY: _____
11-17-2025
 CITY ENGINEER DATE

DRAWING NUMBER
T - 8B



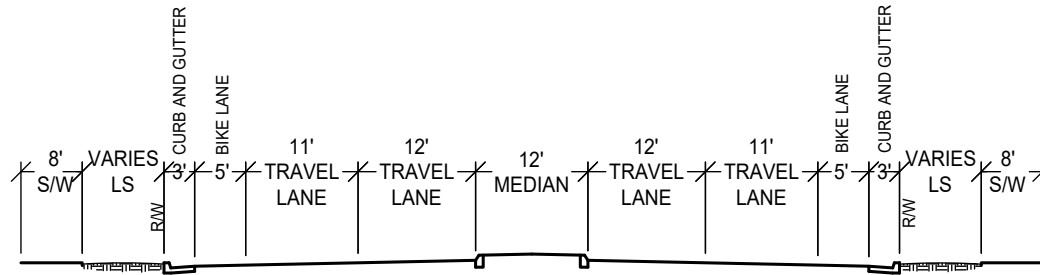

74' STREET

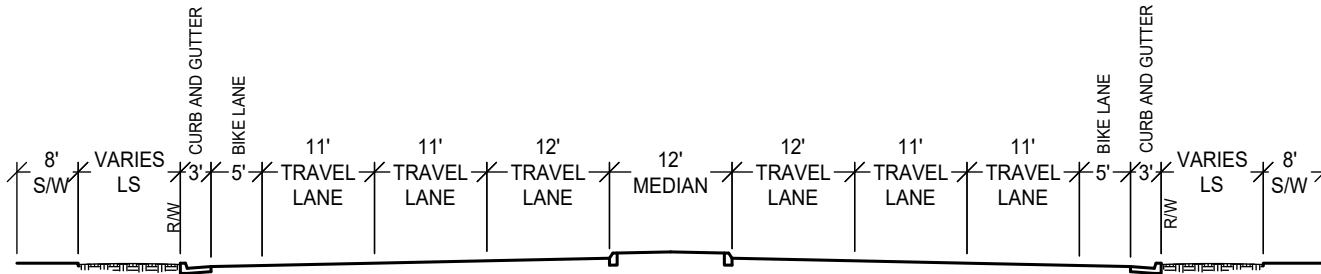

96' STREET

AT THE DISCRETION OF PUBLIC WORKS

- ① LANDSCAPING AND SIDEWALK SHALL BE DEDICATED BY FEE TITLE OR PEDESTRIAN EASEMENT AS APPROVED BY THE DIRECTOR.
- MINOR DEVIATION MAY BE APPROVED BY THE DIRECTOR.

DATE: 09/22/2007		NOT TO SCALE	
REVISION	BY	APPROVED	DATE
1	STN	STN	07-20-2020
2	SJB	SMA	03-07-2025

CITY OF ELK GROVE - PUBLIC WORKS

**TYPICAL STREET CROSS SECTIONS
74' AND 96'**

APPROVED BY:

[Signature] 03-12-2025

CITY ENGINEER

DATE



DRAWING NUMBER

T - 9B

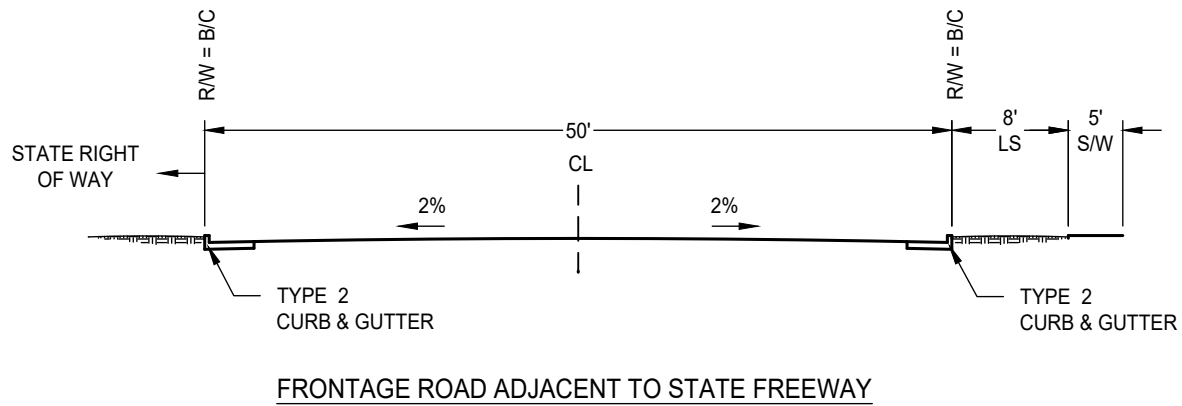
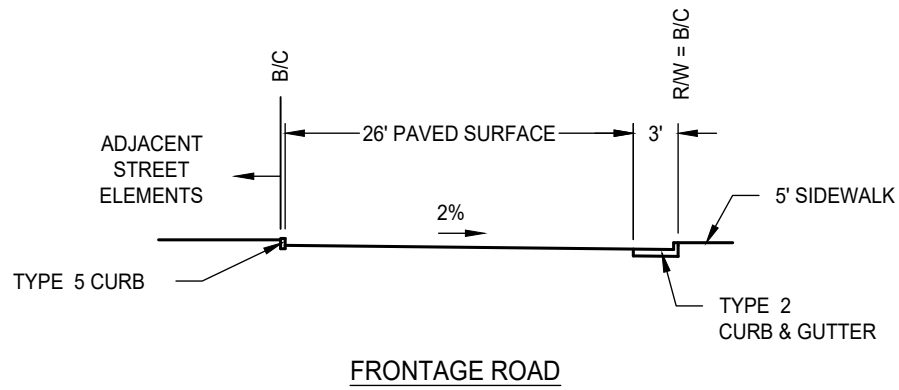

DATE: 09/22/2007		NOT TO SCALE	
REVISION	BY	APPROVED	DATE

CITY OF ELK GROVE - PUBLIC WORKS

**TYPICAL STREET CROSS SECTIONS
FRONTAGE ROAD**

APPROVED BY:

Paul M. Muelich

10/24/2018

CITY ENGINEER

DATE



DRAWING NUMBER

T - 9C

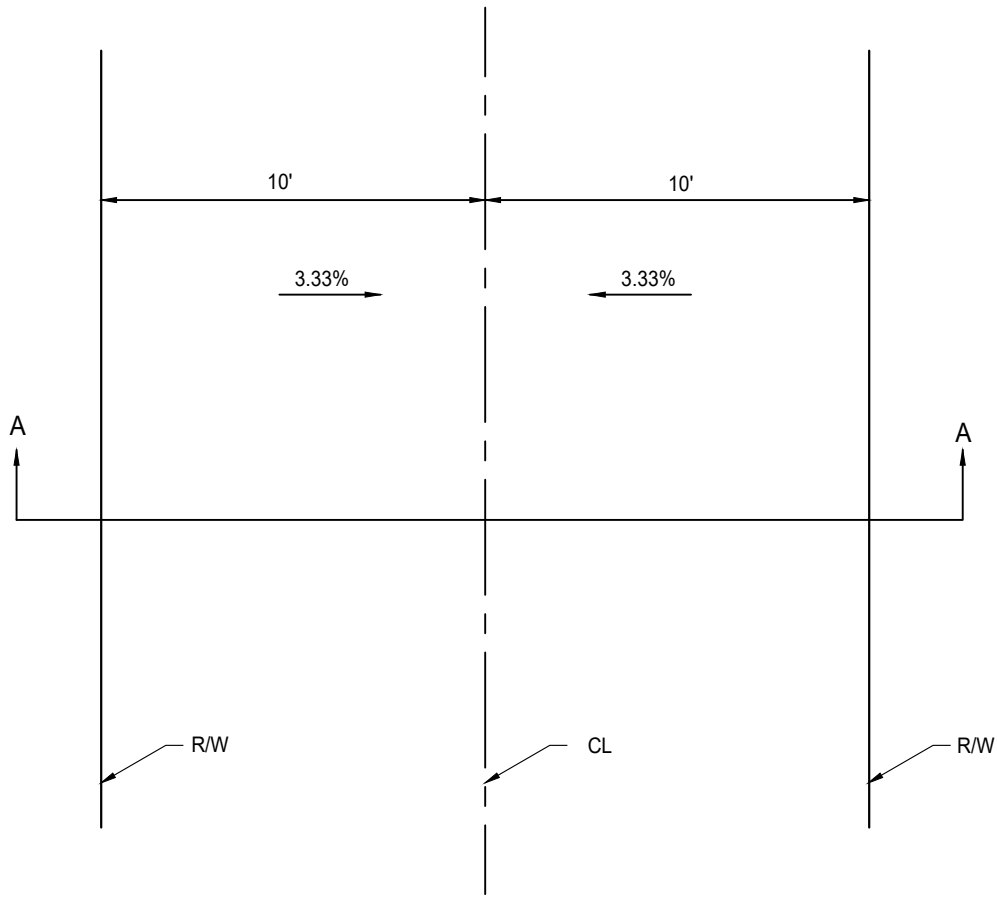

PLAN

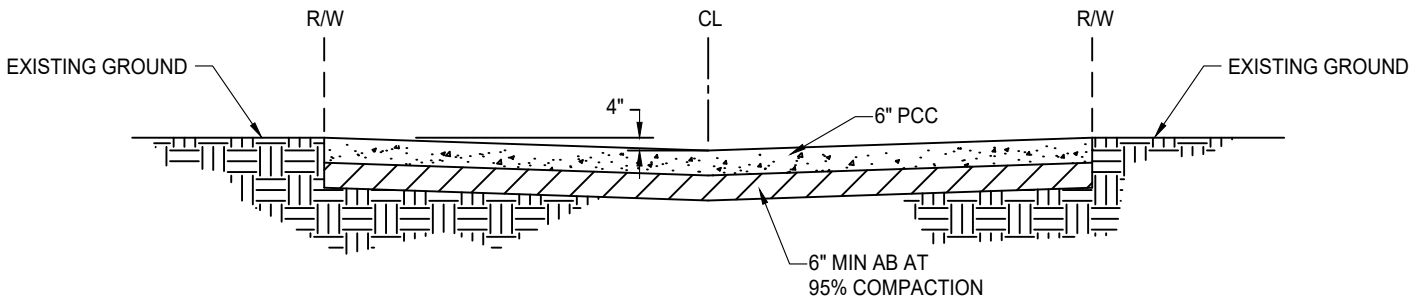

SECTION A-A

NOTE:

1. OTHER STRUCTURAL SECTIONS MAY BE USED WITH SPECIFIC APPROVAL OF THE DIRECTOR (SEE SECTION 4-5 OF THE IMPROVEMENT STANDARDS).

DATE: 09/22/2017		NOT TO SCALE	
REVISION	BY	APPROVED	DATE
1	SJB	SMA	04-12-2024

CITY OF ELK GROVE - PUBLIC WORKS

**20-FOOT STREET
(PRIVATE ALLEY)**

APPROVED BY:

05-28-2024

CITY ENGINEER

DATE



DRAWING NUMBER

T - 9D

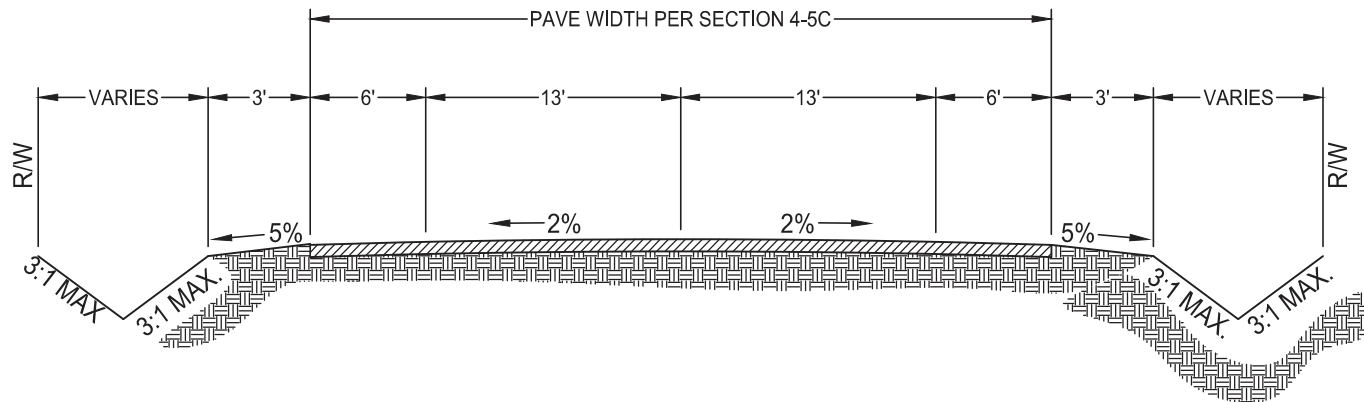

DATE: 09/22/2007		NOT TO SCALE	
REVISION	BY	APPROVED	DATE

CITY OF ELK GROVE - PUBLIC WORKS

CLASS C STREET CROSS SECTION

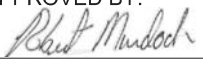
APPROVED BY:

 CITY ENGINEER DATE: 10/24/2018

DRAWING NUMBER
T - 10

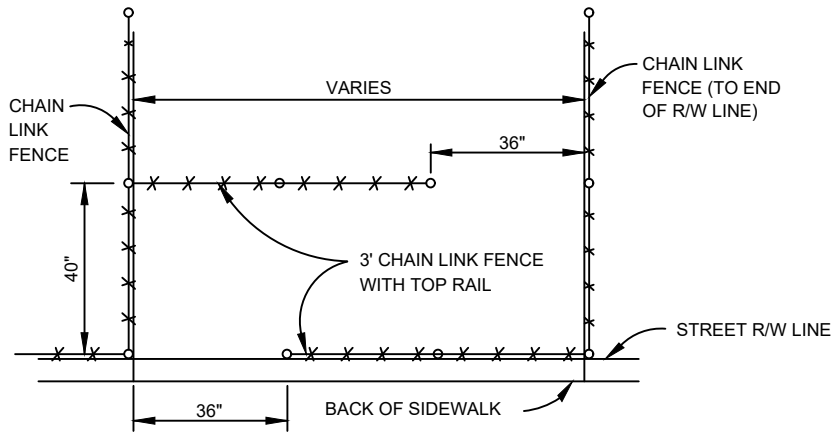

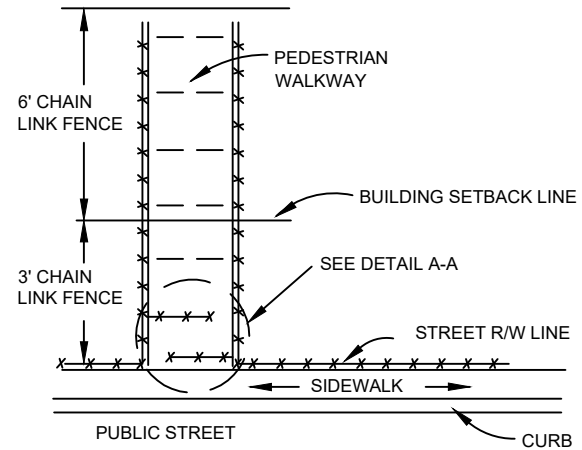

DETAIL A-A



PLAN

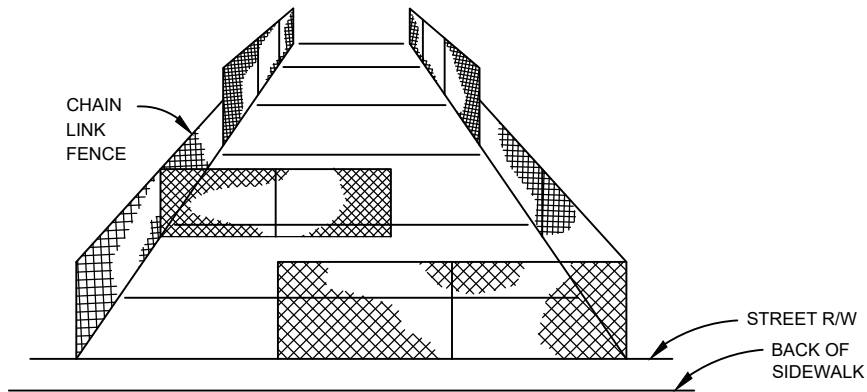

PICTORIAL VIEW

NOTE:

1. CHAIN LINK FENCING SHALL BE 3 FT. HIGH WITH A 1-1/4" DIAMETER TOP RAIL WITHIN THE BUILDING SETBACK LINE AND 6 FT. HIGH OUTSIDE OF THE BUILDING SETBACK LINE. CHAIN LINK FENCING SHALL BE IN ACCORDANCE WITH SECTION 45 OF THE STANDARD SPECIFICATIONS. STREET LIGHTS SHALL BE PLACED AT BOTH ENDS OF THE PEDESTRIAN LANE.

DATE: 09/22/2007		NOT TO SCALE	
REVISION	BY	APPROVED	DATE

CITY OF ELK GROVE - PUBLIC WORKS

**PEDESTRIAN LANE
WITH
BIKE BARRIER**

APPROVED BY:

Paul Murock

CITY ENGINEER

10/24/2018

DATE



DRAWING NUMBER

T - 11

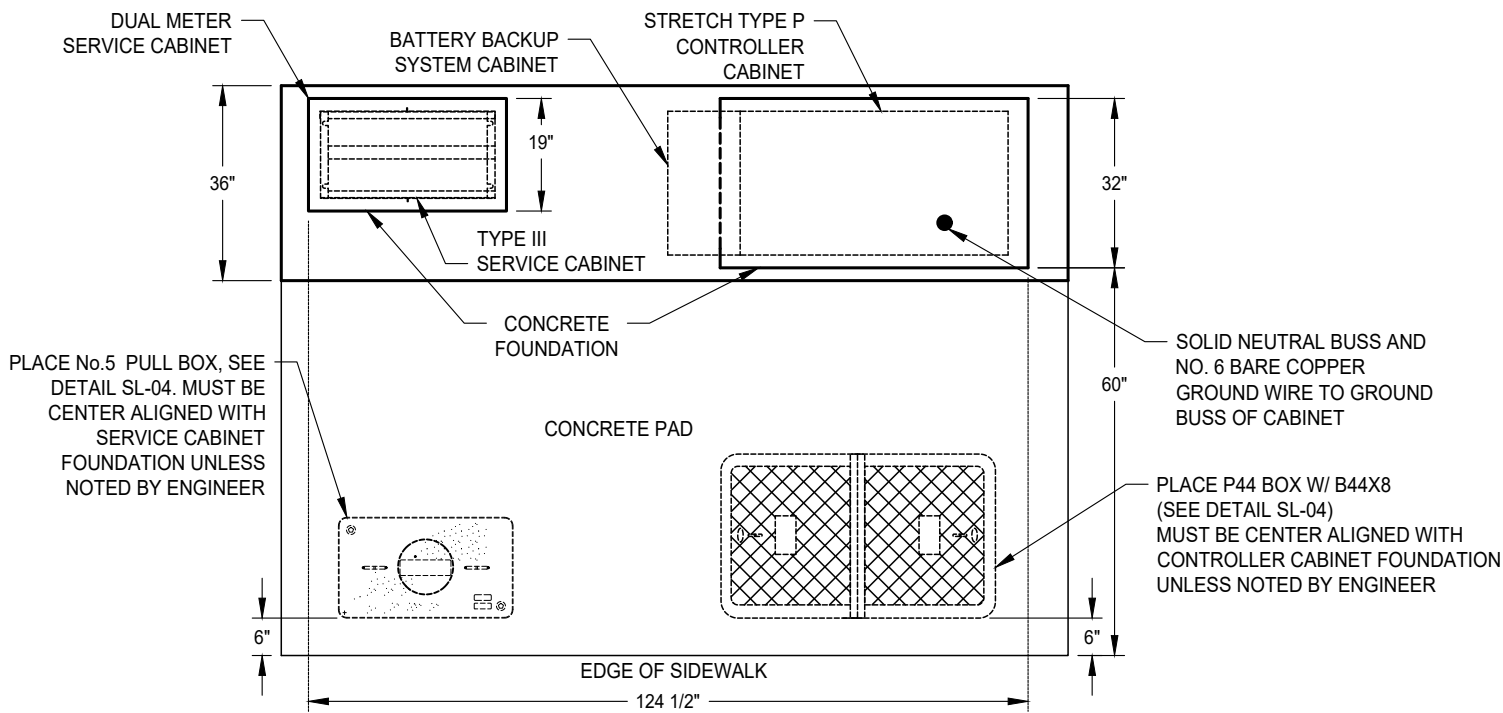

TOP

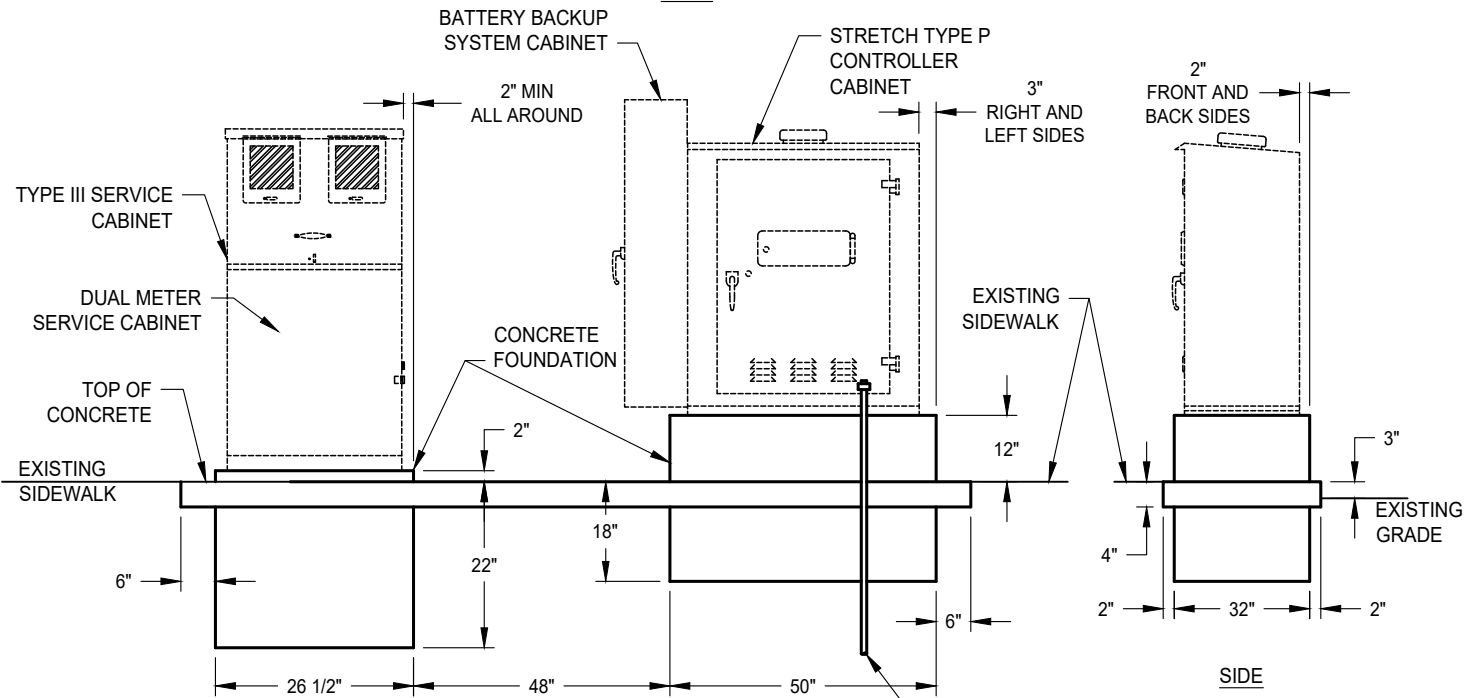

FRONT

SIDE

NOTES:

1. IN UNPAVED AREAS, A RAISED PORTLAND CEMENT PAD SHALL BE CONSTRUCTED IN FRONT OF THE FRONT DOOR OF THE CONTROLLER CABINET (136.5" W x 60" D x 4" THICK).
2. FRONT DOOR OF THE CONTROLLER CABINET SHALL FACE NORTH OR EAST, WHENEVER FEASIBLE. THE FINAL LOCATION OF THE CONTROLLER CABINET AND SERVICE CABINET SHALL BE APPROVED BY THE CITY ENGINEER.
3. TYPE III SERVICES CABINET SHALL BE TESCO MODEL 28-102 TESCOFLEX DUAL METER PEDESTAL.

DATE: 09/22/2017		NOT TO SCALE	
REVISION	BY	APPROVED	DATE
1	SJB	SMA	11-17-2025

CITY OF ELK GROVE - PUBLIC WORKS

**CONCRETE FOUNDATION FOR
TYPE P CONTROLLER CABINET
AND TYPE III SERVICE CABINET**

APPROVED BY: _____
11-17-2025
CITY ENGINEER DATE

DRAWING NUMBER
T - 12



CONDUIT SIZING

CONDUCTOR	EQUIVALENT NUMBER OF #14 A.W.G. CONDUCTORS FOR USE IN CONDUIT SIZING
#12 CONDUCTOR	1.2
#10 CONDUCTOR	1.5
#8 CONDUCTOR	2.3
#6 CONDUCTOR	3
#4 CONDUCTOR	4
#2 CONDUCTOR	5.3
#0 CONDUCTOR	11.5
INTERCONNECT CABLE	18
DETECTOR LEAD-IN CABLE	2.5
EMERGENCY VEHICLE DETECTOR CABLE	2

CONDUIT SIZE	2"	2.5"	3"	3.5"	4"
MAXIMUM NUMBER OF #14 A.W.G. CONDUCTORS	31	44	69	91	113

NOTE: MINIMUM SIZE FOR NEW CONDUITS IS 2".

SERVICE WIRE MAXIMUM LENGTHS
FOR TRAFFIC SIGNALS

WIRE SIZE	LENGTH
#0	576'
#2	360'
#4	224'

CIRCUIT BREAKER SIZING

CONDUCTOR SIZE A.W.G.	MAXIMUM CIRCUIT BREAKER AMPERAGE
#2	100
#4	80
#6	50
#8	40
#10	30

NOTE: THE BREAKER SIZE SHALL BE DETERMINED BY THE LOAD REQUIREMENTS. MINIMUM BREAKER SIZE IS 30 AMPS.

DATE: 09/22/2017		NOT TO SCALE	
REVISION	BY	APPROVED	DATE
1	SJB	SMA	03-28-2024

CITY OF ELK GROVE - PUBLIC WORKS

**CONDUIT, SERVICE WIRE
AND BREAKER SIZING**

APPROVED BY: _____ 05-28-2024
CITY ENGINEER DATE

DRAWING NUMBER
T - 15



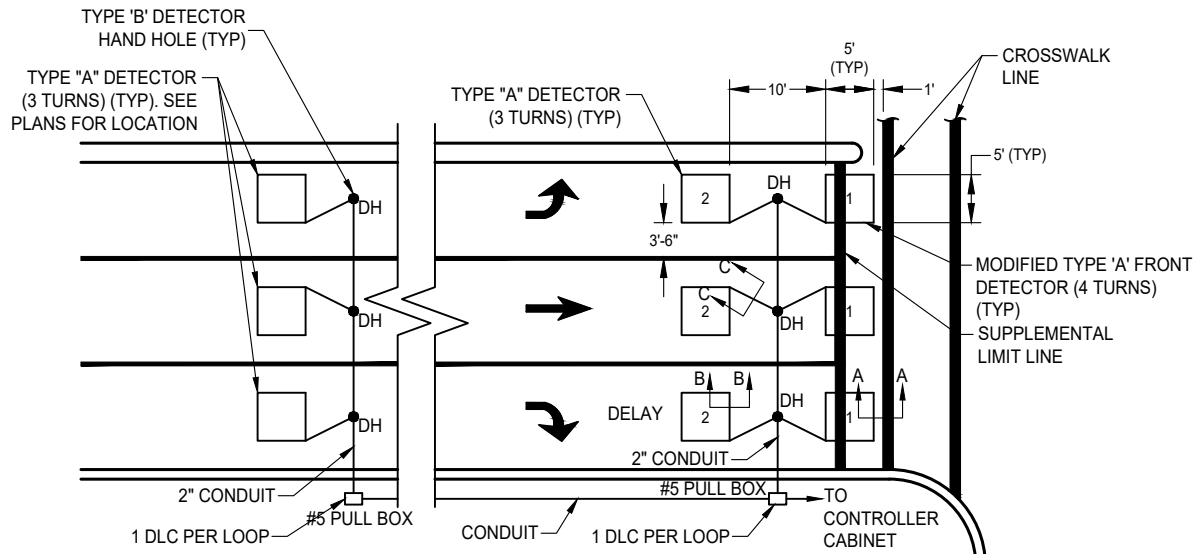

TYPICAL LOOP INSTALLATION

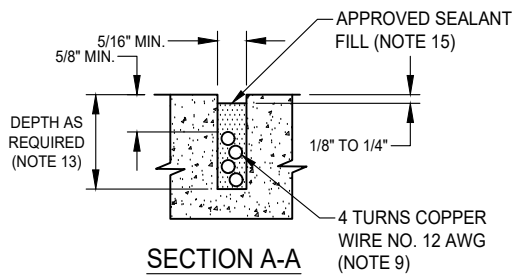

SECTION A-A

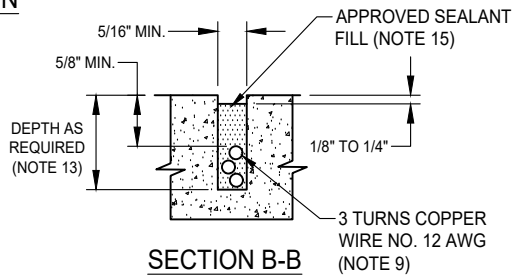

SECTION B-B

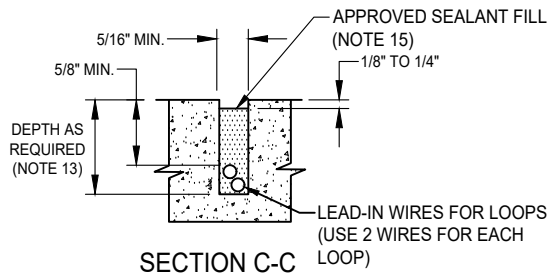

SECTION C-C

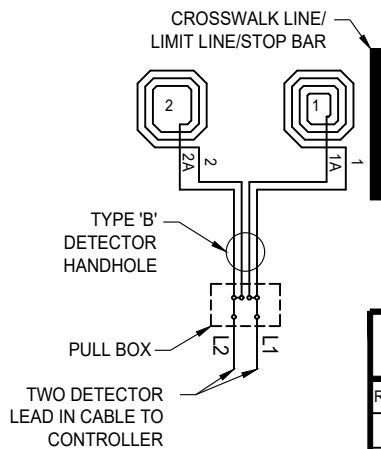

LOOP WINDING AND CONNECTION PATTERNS

LOOP INSTALLATION PROCEDURE

1. ALL LOOP WORK SHALL CONFORM TO THE LATEST VERSION OF SECTION 49-5 "DETECTOR" OF THE CITY OF ELK GROVE STANDARD CONSTRUCTION SPECIFICATIONS AND STANDARD DRAWINGS.
2. SEE CURRENT STATE STANDARD PLANS ES-5 SERIES FOR ADDITIONAL DETAILS.
3. THE PLACEMENT OF LOOPS SHALL BE CENTERED IN EACH LANE, WITH THE EXCEPTION OF: LEFT TURN LANE LESS THAN 11' WIDE, THE SEPARATION DISTANCE BETWEEN THE RIGHT EDGE OF EACH LOOP AND THE LANE ON THE RIGHT (THRU LANE) SHOULD BE 3'-6".
4. NEW OR REPLACEMENT LOOP SHALL BE MARKED ON PAVEMENT AND THEIR LOCATION APPROVED BY THE ENGINEER, PRIOR TO PAVEMENT CUTTING.
5. LOOP INSTALLATION SHALL INCLUDE NEW CONDUIT, DETECTOR HANDHOLE (DH) AND DETECTOR LEAD IN CABLE (DLC), UNLESS OTHERWISE NOTED ON THE PLANS.
6. EACH DETECTOR LOOP IN EACH TRAVEL LANE SHALL BE INSTALLED WITH ITS OWN DETECTOR LEAD IN CABLE AND CONNECTED IN CONTROLLER WITH SEPARATE DETECTOR CHANNEL FOR OPERATION, UNLESS OTHERWISE NOTED ON THE PLANS.
7. DETECTOR LEAD IN CABLES SHALL BE CONTINUOUS WITHOUT SPLICES BETWEEN LOOP TERMINATION PULL BOX AND CONTROLLER.
8. LOOP INSTALLATION 250' OR MORE FROM STOP BAR SHALL HAVE 4 TURNS.
9. DETECTOR LOOP CONDUCTOR SHALL BE TYPE RHW-USE NEOPRENE-JACKETED OR TYPE USE CROSSLINKED POLYPROPYLENE INSULATED NO. 12 STRANDED COPPER WIRE. CONDUCTOR INSULATION THICKNESS SHALL BE FORTY (40) MILS MINIMUM.
10. DISTANCE BETWEEN SIDE OF LOOP AND LEAD-IN SAW CUT SHALL BE 1'-0" MINIMUM.
11. LOOPS AND LEAD-IN CUTS SHALL BE LOCATED A MINIMUM OF 2 FEET FROM THE NEAREST EDGE OF MANHOLE COVER OR VALVE BOX.
12. WIDTH OF SAW CUTS SHALL BE 1/4" WIDER THAN THICKNESS OF THE CONDUCTOR.
13. DEPTH OF SAW CUTS SHALL BE SUCH THAT THE MINIMUM SEALANT COVER SHALL BE 1/2" WITH AN ADDITIONAL 1/8" TO 1/4" GAP BETWEEN TOP OF SEALANT AND SURFACE OF PAVEMENT.
14. TEST EACH LOOP CIRCUIT AT CONTROLLER CABINET (OR, IF THESE ARE NOT INSTALLED, TEST AT TERMINATION PULL BOX) BEFORE FILLING SLOTS. PERFORM A RESISTANCE TEST BETWEEN EACH CIRCUIT AND GROUND. INSULATION RESISTANCE SHALL NOT BE LESS THAN 100 MEGA OHMS. TEST EACH LOOP CIRCUIT FOR CONTINUITY. LOOP CIRCUIT RESISTANCE SHALL NOT EXCEED 0.5 OHMS PLUS 0.35 OHMS PER 100 FEET OF LEAD-IN CABLE.
15. SEALANT FOR LOOP DETECTORS SHALL BE 3M 5000 OR APPROVED EQUAL ELASTOMERIC SEALANT.
16. CONDUIT BETWEEN DETECTOR HANDHOLE AND PULL BOX SHALL BE INSTALLED 30" MINIMUM BELOW ROADSIDE DITCH OR SWALE.
17. DETECTOR HANDHOLE (DH) SHALL BE TYPE B (SEE STD DWG T - 17).
18. ANY DAMAGE TO EXISTING LOOPS, DETECTOR HANDHOLE, CONDUIT AND DETECTOR LEAD IN CABLE SHALL BE REPLACED PER THE REQUIREMENTS SET FORTH IN THIS DETAIL.

DATE: 09/22/2007		NOT TO SCALE	
REVISION	BY	APPROVED	DATE

CITY OF ELK GROVE - PUBLIC WORKS

TYPICAL DETECTOR LOOP LAYOUTS

APPROVED BY:
Paul Muddoch 10/24/2018
CITY ENGINEER DATE



DRAWING NUMBER

T - 16

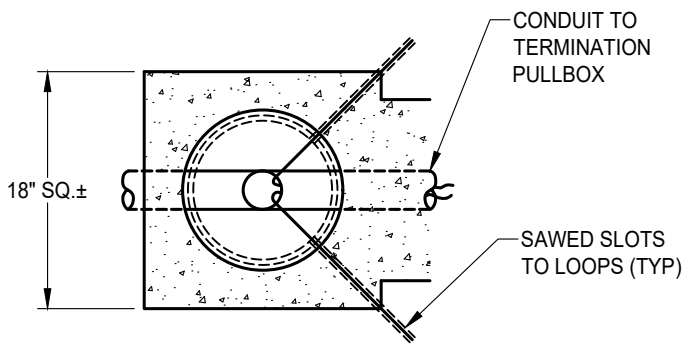
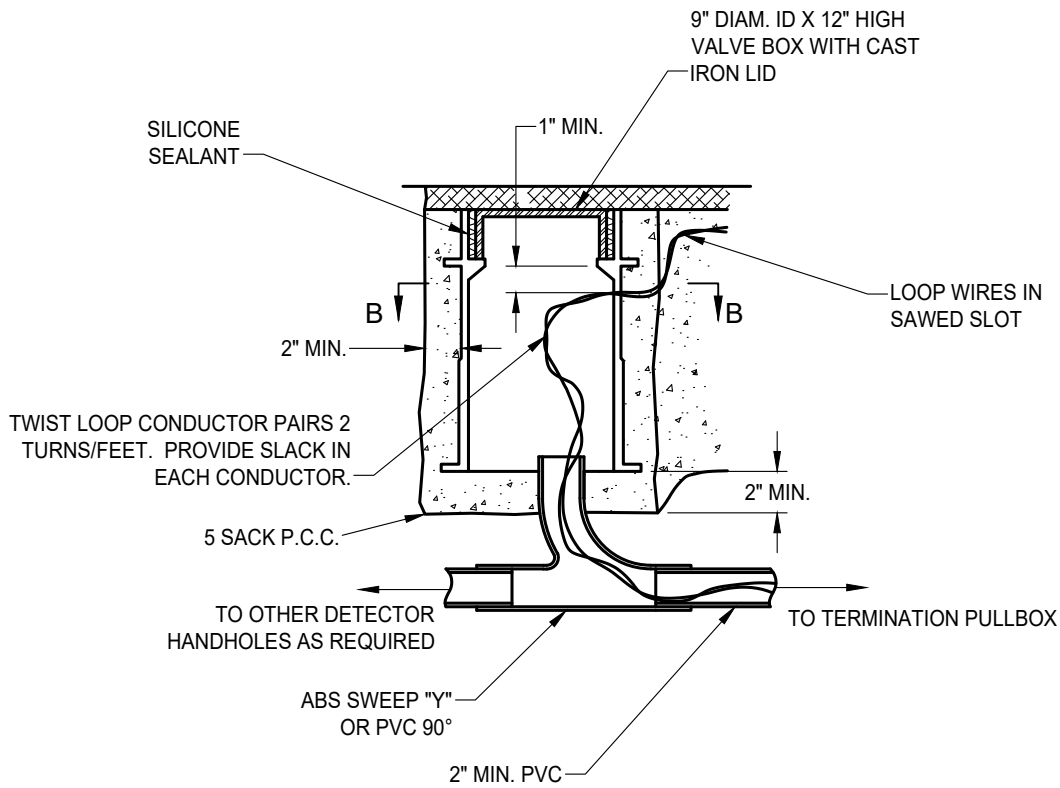

SECTION B-B

INSTALLATION REQUIREMENTS:

1. 18" SQ.± P.C.C. ENCASUREMENT OUTLINE SHALL BE SAW CUT TO A MINIMUM DEPTH OF 3", EXCEPT WHERE AC OVERLAY IS TO BE PLACED.
2. THE PRECAST VALVE BOX WITH CAST IRON LID SHALL BE FABRICATED OF CALCIUM CARBONATE AND POLYESTER RESINS WITH FIBERGLASS REINFORCING AND DESIGNED FOR HEAVY TRAFFIC LOADS.
3. CAST IRON LID SHALL BE MARKED "DETECTOR" AND SHALL BE SECURED IN PLACE BY APPLYING SILICONE SEALANT. VALVE BOX LOCATION SHALL BE AS SHOWN ON THE PLANS.
4. THE EXCAVATION AROUND THE HANDHOLE SHALL BE BACKFILLED WITH 5 SACK P.C.C.
5. THE HANDHOLE SHALL BE PROTECTED WITH COLD PATCH OR OTHER SUITABLE PROTECTION UNTIL PERMANENT A.C. BACKFILL IS PLACED.
6. THE CEMENT USED TO JOIN THE ABS SWEEP "Y" TO THE PVC CONDUIT SHALL BE CAPABLE OF PROVIDING SOLVENT TYPE WELD BETWEEN THE TWO MATERIALS.

DATE 09/22/2017		NOT TO SCALE	
REVISION	BY	APPROVED	DATE

CITY OF ELK GROVE - PUBLIC WORKS

TYPE "B" DETECTOR HANDHOLE DETAIL

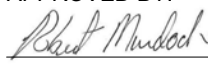
APPROVED BY:

 10/24/2018
 CITY ENGINEER DATE



DRAWING NUMBER

T - 17

GENERAL INSTALLATION NOTES - ALL CABINETS

1. ALL CABINET DIMENSIONS ARE NOMINAL
2. FOUNDATION SHALL BE LOCATED AS SHOWN ON PLANS. WHERE INSTALLED IN SIDEWALK PLACE AT BACK OF WALK AND PROVIDE 48" MINIMUM CLEARANCE BETWEEN FACE OF CURB AND FRONT OF CABINET.
3. ONE ANCHOR BOLT SHALL BE BONDED TO CONDUIT OR GROUND WIRE.
4. SERVICE CAN, CONTROLLER CABINET, AND TERMINAL CABINET (IF NECESSARY) SHALL BE ON A COMMON FOUNDATION WITH 6" SPACING, UNLESS OTHERWISE DIRECTED BY THE ENGINEER. THE SERVICE CAN SHALL BE TO THE LEFT OF THE CONTROLLER CABINET SO AS TO NOT BE BLOCKED BY CONTROLLER CABINET DOOR WHEN FULLY OPEN.
5. APPROVED WATERPROOF SEAL TO BE APPLIED TO BASE OF CABINETS AND CONCRETE FOUNDATION.
6. IN UNIMPROVED AREAS A RAISED P.C.C. PAD OF 36" X 30" X 4" SHALL BE PLACED IN FRONT OF EACH CABINET.
7. IN ALL UNPAVED AREAS TOP OF FOUNDATION FOR CABINETS SHALL BE 6" ABOVE SURROUNDING GRADE. IN PAVED AREAS TOP OF FOUNDATION SHALL BE 3" ABOVE PAVED AREA.
8. ANCHOR BOLTS, NUTS, AND WASHERS SHALL BE GALVANIZED.
9. ALL CONDUITS SHALL BE BOUNDED TOGETHER IN THE CABINET.
10. LOCATIONS SHOWN FOR EQUIPMENT ARE TYPICAL ONLY.
11. A 1/2" DIAMETER DRAIN HOLE SHALL BE FORMED IN THE CABINET BASE. ALL CABINETS SHALL BE LEVELED SO THAT THE CABINET DOOR WILL OPEN AND CLOSE EASILY.

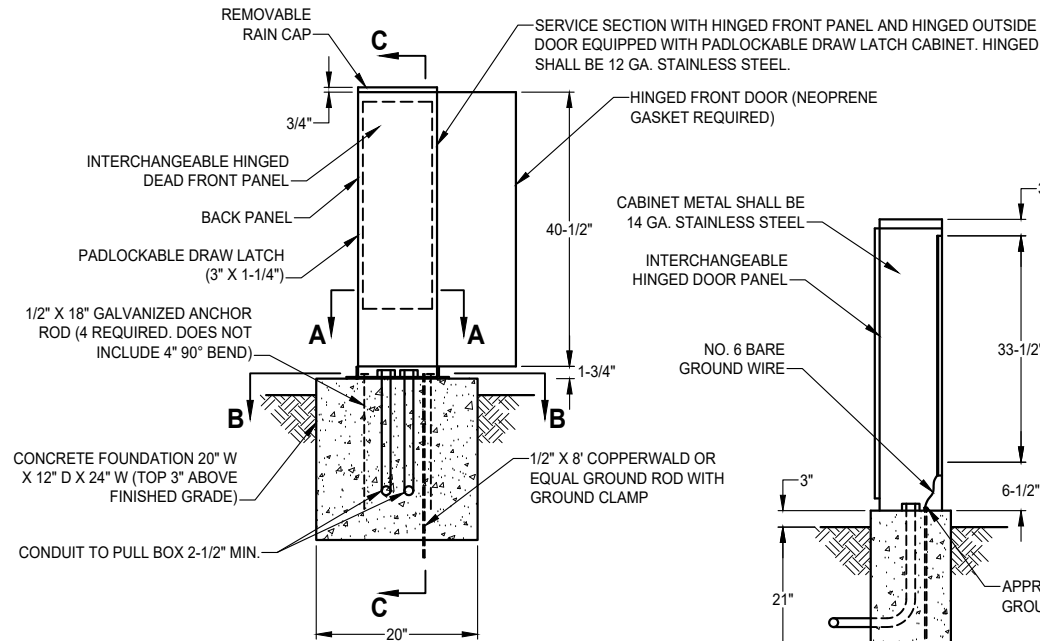

FRONT VIEW

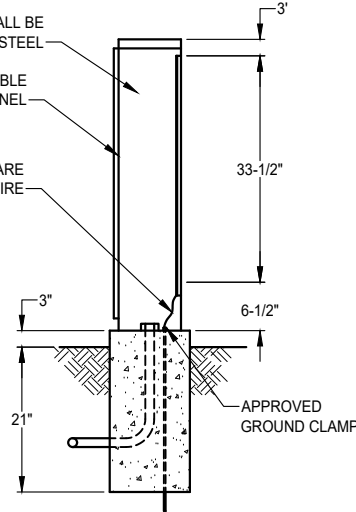

SECTION C-C

TRAFFIC SIGNAL INTERCONNECT TERMINAL CABINET OR PEDESTRIAN SIGNAL CONTROLLER CABINET

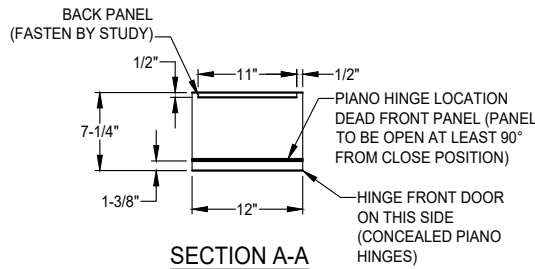

SECTION A-A

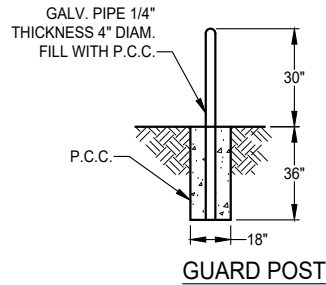

GUARD POST

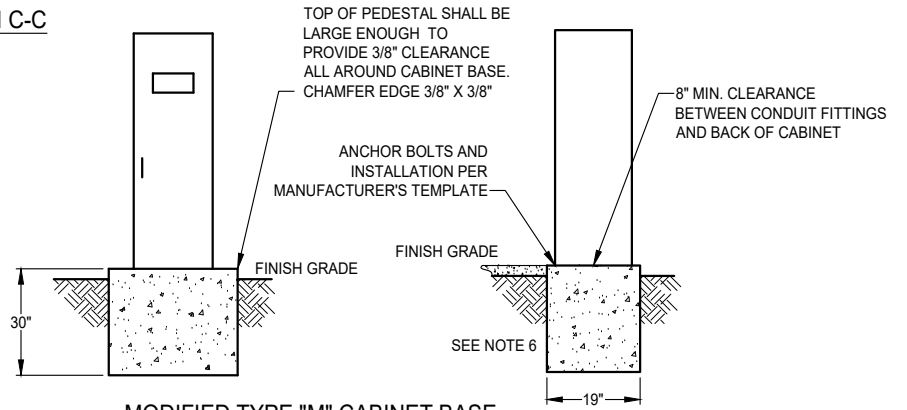

MODIFIED TYPE "M" CABINET BASE

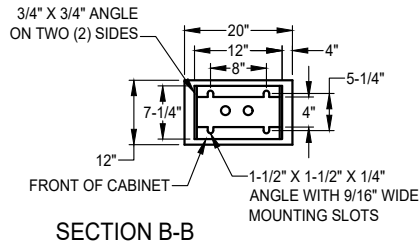

SECTION B-B

DATE: 09/22/2007		NOT TO SCALE	
REVISION	BY	APPROVED	DATE
1	SJB	SMA	03-28-2024

CITY OF ELK GROVE - PUBLIC WORKS

INTERCONNECT TERMINAL CABINET AND PEDESTRIAN SIGNAL CONTROLLER CABINET DETAILS

APPROVED BY:  05-28-2024

CITY ENGINEER DATE

DRAWING NUMBER

T - 18



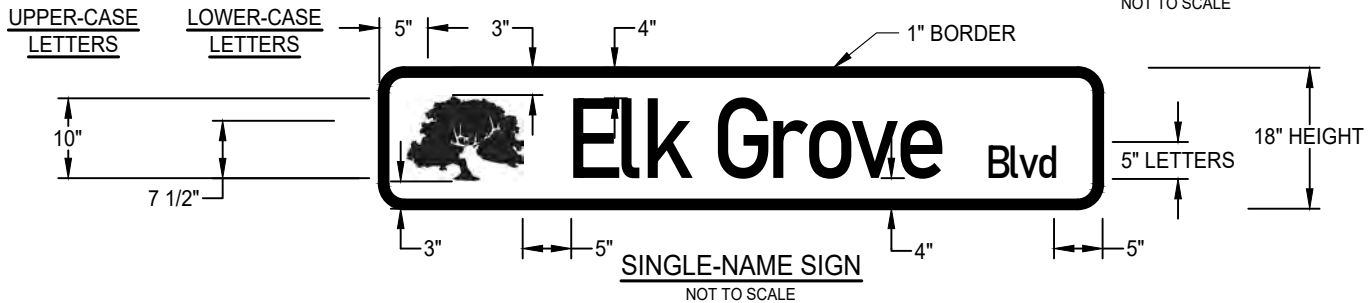
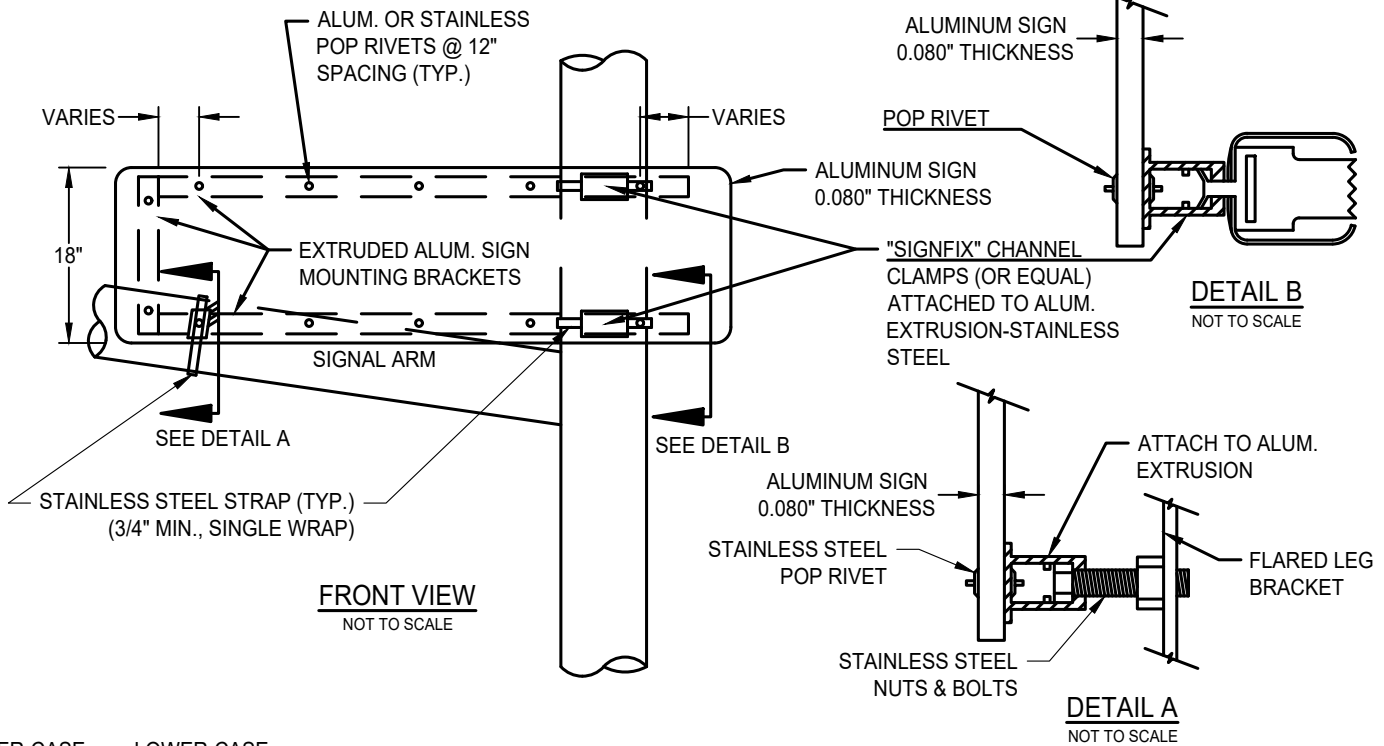

(SEE NOTE NO. 3 ON STD DWG T-21.2)

* IN THE EVENT THE STREET NAME INCLUDES A LOWER CASE LETTER g, j, p,q, or y, THE TOP AND BOTTOM BUFFER DISTANCES SHALL BE ADJUSTED TO 2.25" and 5.75", RESPECTIVELY.

DATE 6/21/2021		NOT TO SCALE	
REVISION	BY	APPROVED	DATE
1	SJB	SMA	02-23-2024
2	SJB	SMA	11-14-2025

CITY OF ELK GROVE - PUBLIC WORKS

**TRAFFIC SIGNAL MAST ARM
SIGN ASSEMBLY (1 OF 2)**

APPROVED BY:

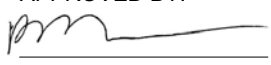

11-14-2025
DATE

CITY ENGINEER

DRAWING NUMBER
T - 21.1



NOTES FOR TRAFFIC-SIGNAL-ARM SIGN MOUNTING:



1. ALL MATERIAL FURNISHED SHALL BE RUST RESISTANT. ALL SIGN HARDWARE SHALL BE ALUMINUM AND ANY MOVING PARTS MUST BE MADE OF STAINLESS STEEL TO PREVENT RUSTING.

2. THE SIGN MOUNTING EXTRUDED ALUMINUM MOUNTING BRACKETS SHALL BE EITHER MEDIUM ALUMINUM EXTRUSIONS (SIGNFIX PART NO. SX-073) OR LARGER ALUMINUM EXTRUSIONS (SIGNFIX PART NO. SX-0130). EXTRUDED ALUMINUM MOUNTING BRACKETS MUST BE BY SIGNFIX OR MUST BE DIRECTLY ADAPTABLE TO UNIVERSAL SIGNFIX CHANNEL CLAMPS E.P. (PART NO. SX-0220) OR EQUAL. FLARED LEG MOUNTING BRACKET FOR MOUNTING TO POLE OR MAST ARM SHALL BE BAND-IT C206R9 3/4-INCH 2250 LB TENSION CAPACITY OR APPROVED EQUAL. 1 3/4-INCH THREADED ALUMINUM T-BOLT TO ATTACH SIGN TO FLARED LEG BRACKET SHALL BE MD SOLUTIONS PART #PC:B-TB3813 4-AL OR APPROVED EQUAL.

3. SINGLE STREET NAME SIGN SHALL HAVE NAME AND SUFFIX CENTERED IN SIGN. CITY OF ELK GROVE LOGO IS 16.4 INCHES IN LENGTH BY 12 INCHES IN HEIGHT AND SPACED 5-INCHES FROM THE LEFT EDGE AND CENTERED VERTICALLY. SIGNS SHALL BE SINGLE FACE AND FABRICATED ON ALUMINUM BLANKS 0.080-INCH THICKNESS. BLANK SHALL BE 18-INCHES IN HEIGHT AND VARY IN LENGTH DEPENDING ON THE NUMBER OF LETTERS OF THE STREET (MIN. OF 6-FEET IN LENGTH). SIGN BLANK SHALL HAVE GREEN ELECTRO CUT FILM (EC) OVER 3M DIAMOND GRADE REFLECTIVE VINYL SHEETING. UPPER CASE LETTERS SHALL BE 10-INCHES AND LOWER CASE LETTERS SHALL BE 7.5-INCHES. ALL LETTERS SHALL BE HIGHWAY FONT "D". SIGN SHALL HAVE 1-INCH WHITE BORDER COVERING THE ENTIRE EDGE OF SIGN BLANK. CORNERS SHALL BE NEATLY ROUNDED TO A 3-INCH RADIUS. THERE SHALL BE 5-INCHES SPACING BETWEEN BORDER AND SIDES OF STREET NAME. LETTERS SHALL BE SPACED A MINIMUM OF 1 1/2-INCHES.

4. VARIOUS STREETS IN THE CITY CHANGE NAMES AT MAJOR INTERSECTIONS. SIGNS THAT DESIGNATE DIFFERENT NAMES SHALL BE MADE AS PER STANDARD DRAWING NO. T-21.1, PAGE 1.

5. ALL SIGNS SHALL BE APPROVED FOR CONFORMANCE BY THE CITY OPERATION AND MAINTENANCE STAFF PRIOR TO INSTALLATION. TO SCHEDULE AN INSPECTION PLEASE CALL (916) 687-3005.

DATE 6/21/2021		NOT TO SCALE		CITY OF ELK GROVE - PUBLIC WORKS		APPROVED BY:  CITY ENGINEER		11-14-2025 DATE			
REVISION	BY	APPROVED	DATE	TRAFFIC SIGNAL MAST ARM SIGN ASSEMBLY (2 OF 2)				DRAWING NUMBER			
1	SJB	SMA	02-23-2024						T - 21.2		
1	SJB	SMA	11-14-2025								



Fiber Backbone Network

- FIBER BACKBONE NETWORK
- ARTERIAL
- PARK
- COLLECTOR
- PARK
- SCHOOL

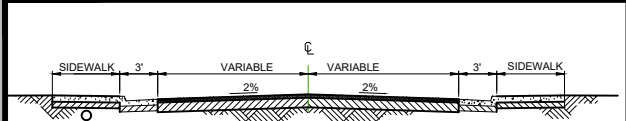
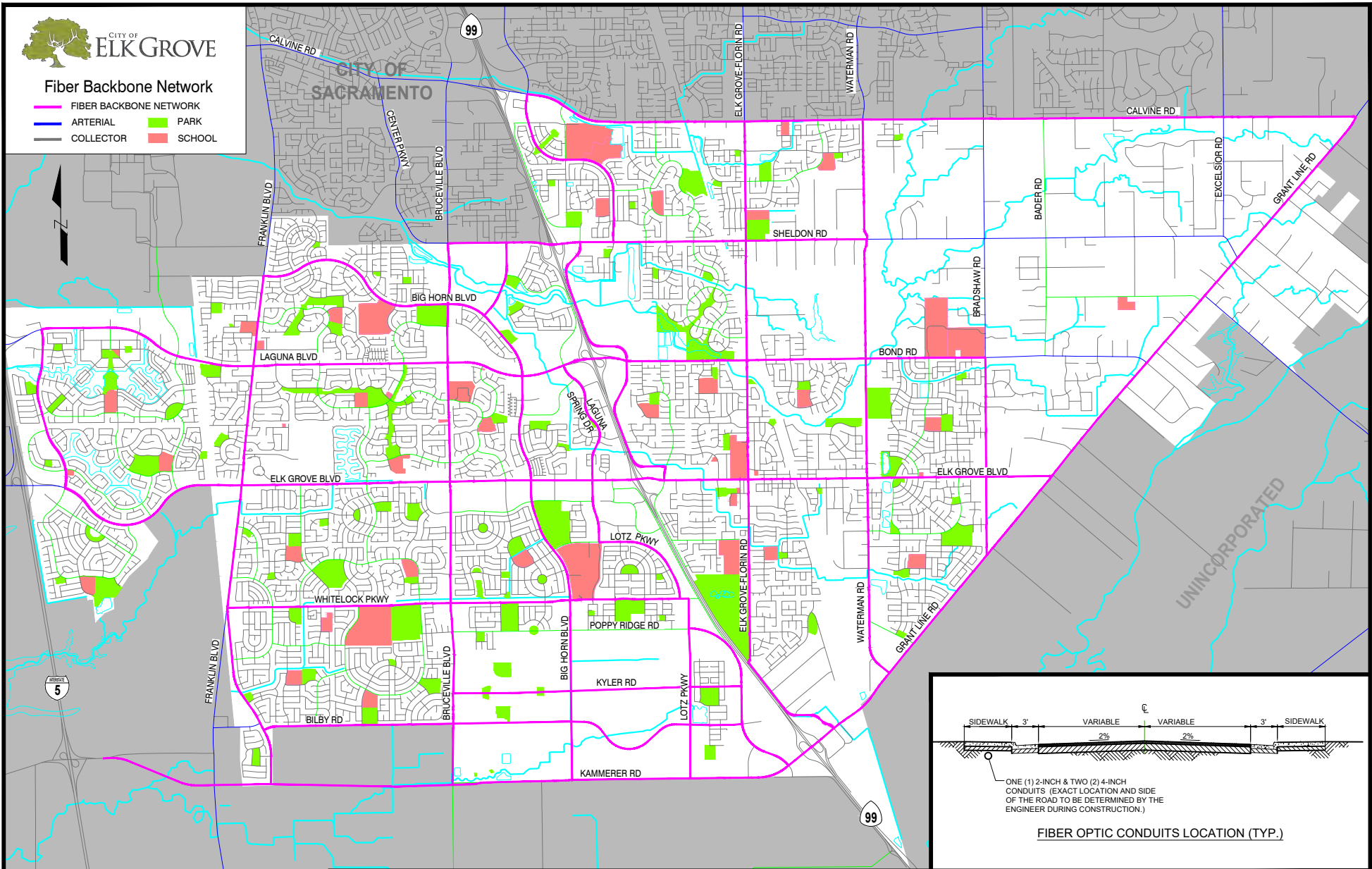

FIBER OPTIC CONDUITS LOCATION (TYP.)

DATE		NOT TO SCALE	
6/21/2021			
REVISION	BY	APPROVED	DATE
1	SJB	SMA	03-28-2024

CITY OF ELK GROVE - PUBLIC WORKS

APPROVED BY:  05-28-2024
CITY ENGINEER DATE

FIBER BACKBONE NETWORK



DRAWING NUMBER
T - 22